

A

B

C

D

1

1

2

2

3

3

4

4

ADSP-SC589 MINI Board Schematic

		2 Elizabeth Drive Chelmsford, MA 01824 PH: 1-800-ANALOGD	
Title		ADSP-SC589 MINI Board Title Block	
Size C	Board No.	A0939-2016	Rev 1.4
Date	10/12/16	Sheet	1 of 18

A

B

C

D

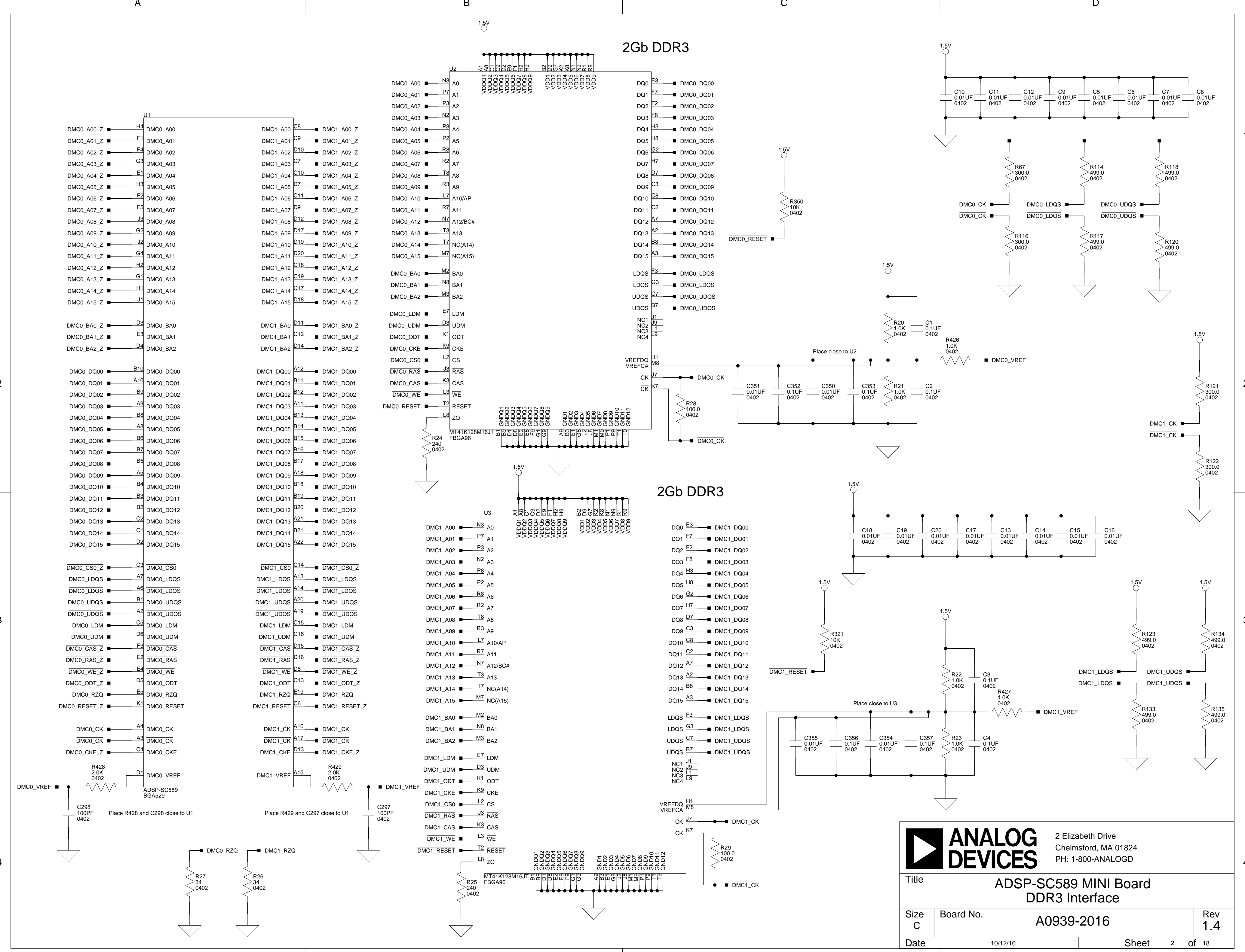

		2 Elizabeth Drive Chelmsford, MA 01824 PH: 1-800-ANALOGD	
		Title ADSP-SC589 MINI Board DDR3 Interface	
Size C	Board No. A0939-2016	Rev 1.4	
Date 10/12/16	Sheet 2 of 18		Page 4

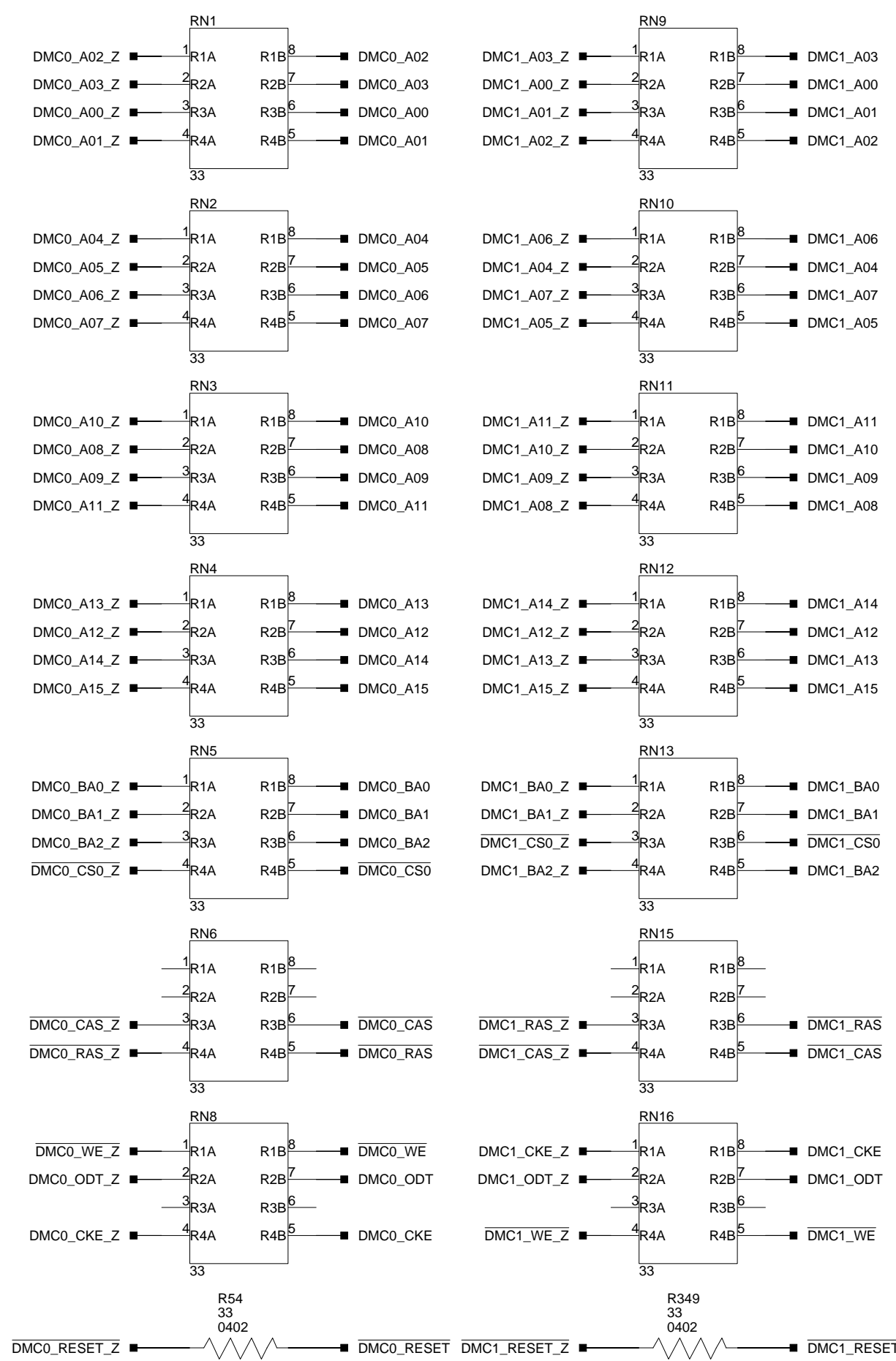

		2 Elizabeth Drive Chelmsford, MA 01824 PH: 1-800-ANALOGD	
Title ADSP-SC589 MINI Board DDR3 Terminators			
Size C	Board No. A0939-2016	Rev 1.4	
Date 10/12/16	Sheet 3 of 18		

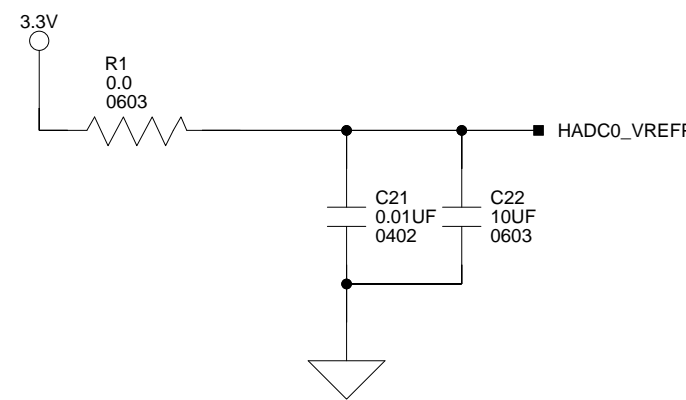
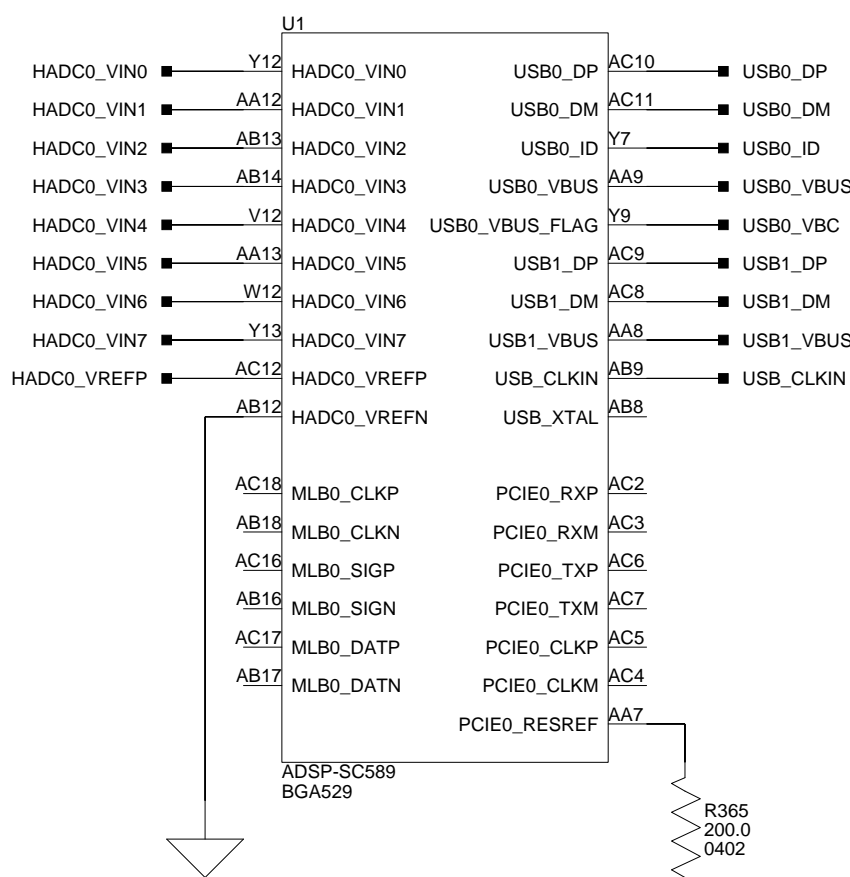
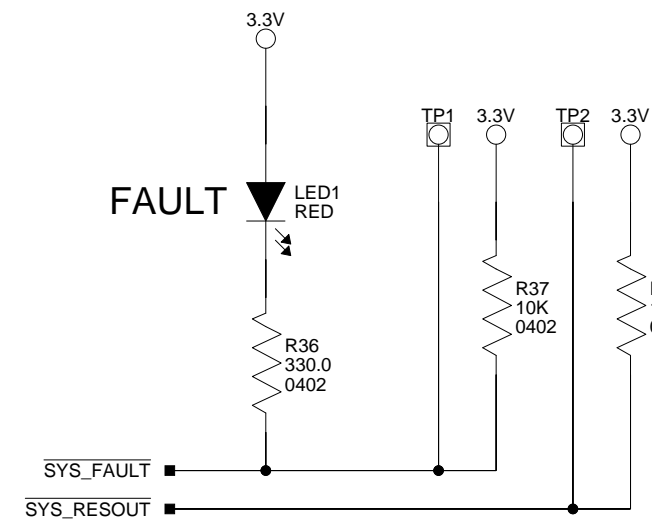
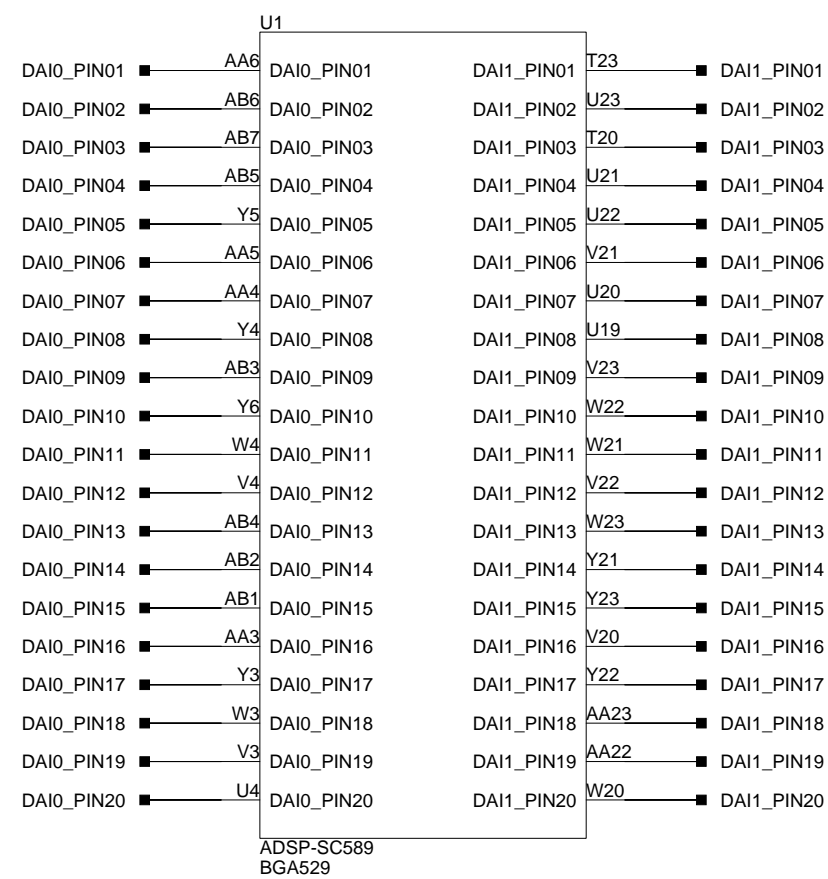

TWI Switch for A2B and ADAU1761

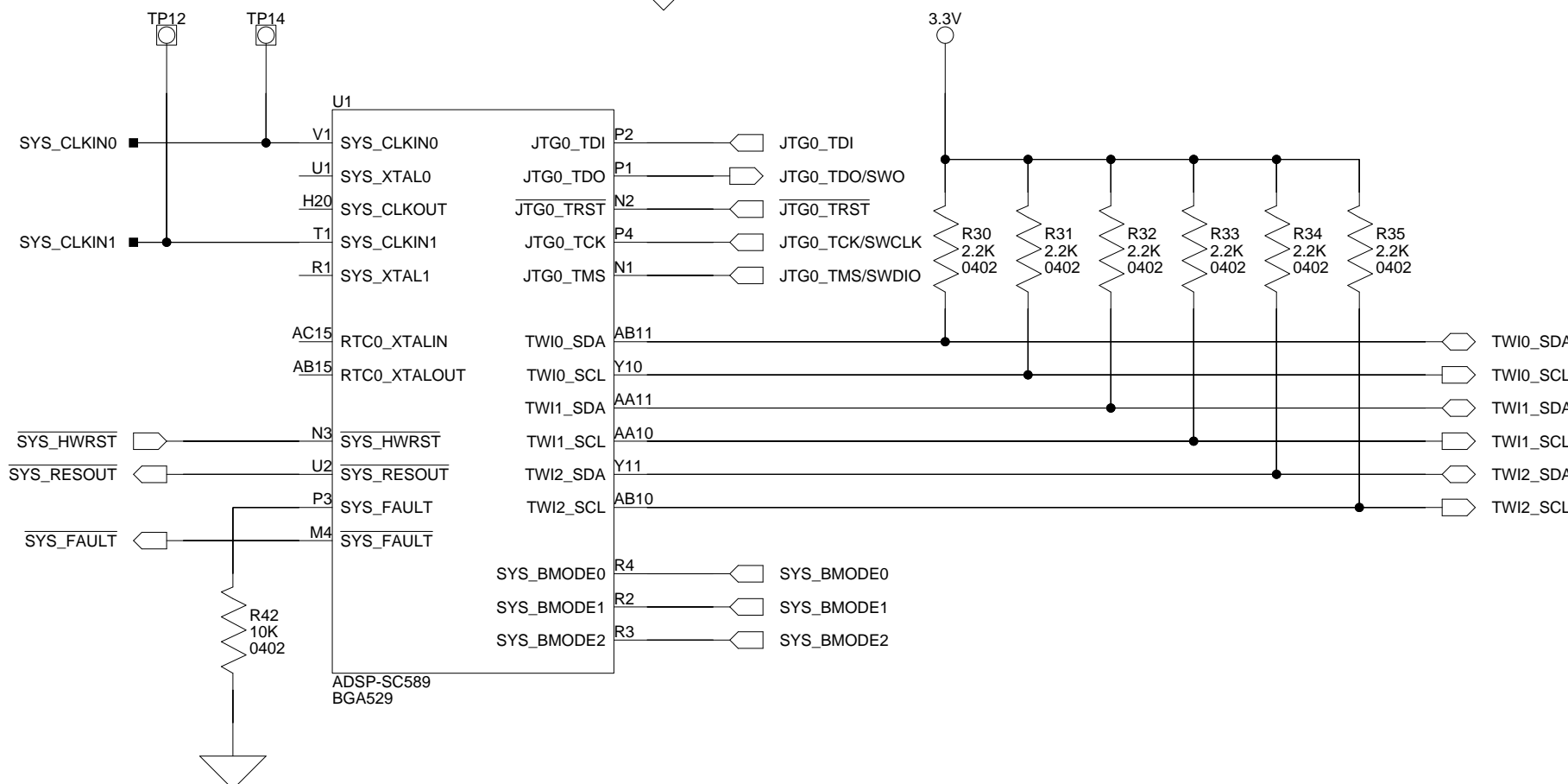
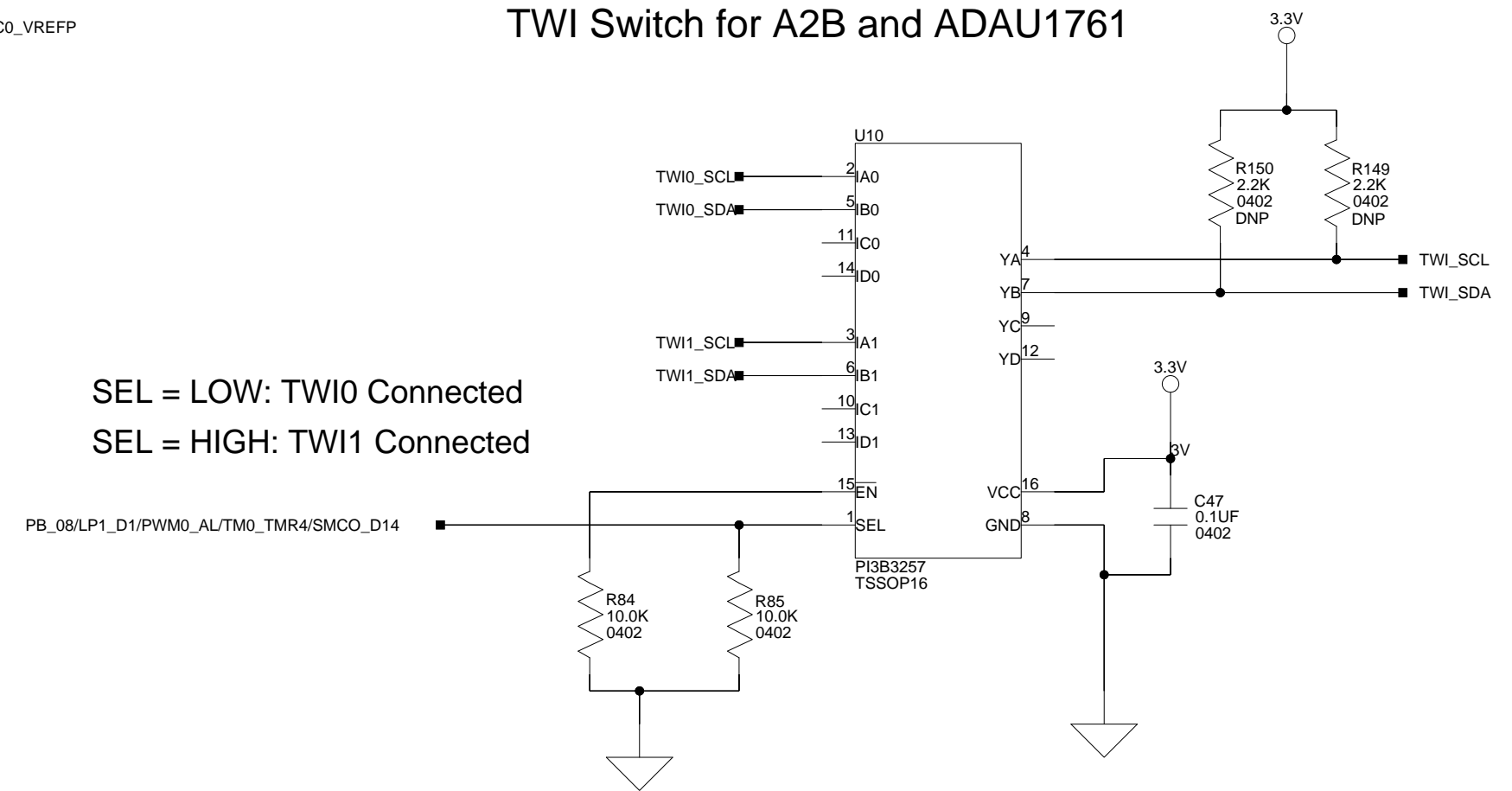

		2 Elizabeth Drive Chelmsford, MA 01824 PH: 1-800-ANALOGD	
Title ADSP-SC589 MINI Board Non-Mux Ports			
Size C	Board No. A0939-2016	Rev 1.4	
Date 10/12/16	Sheet 4 of 18		

1

1

2

2

3

3

4

4

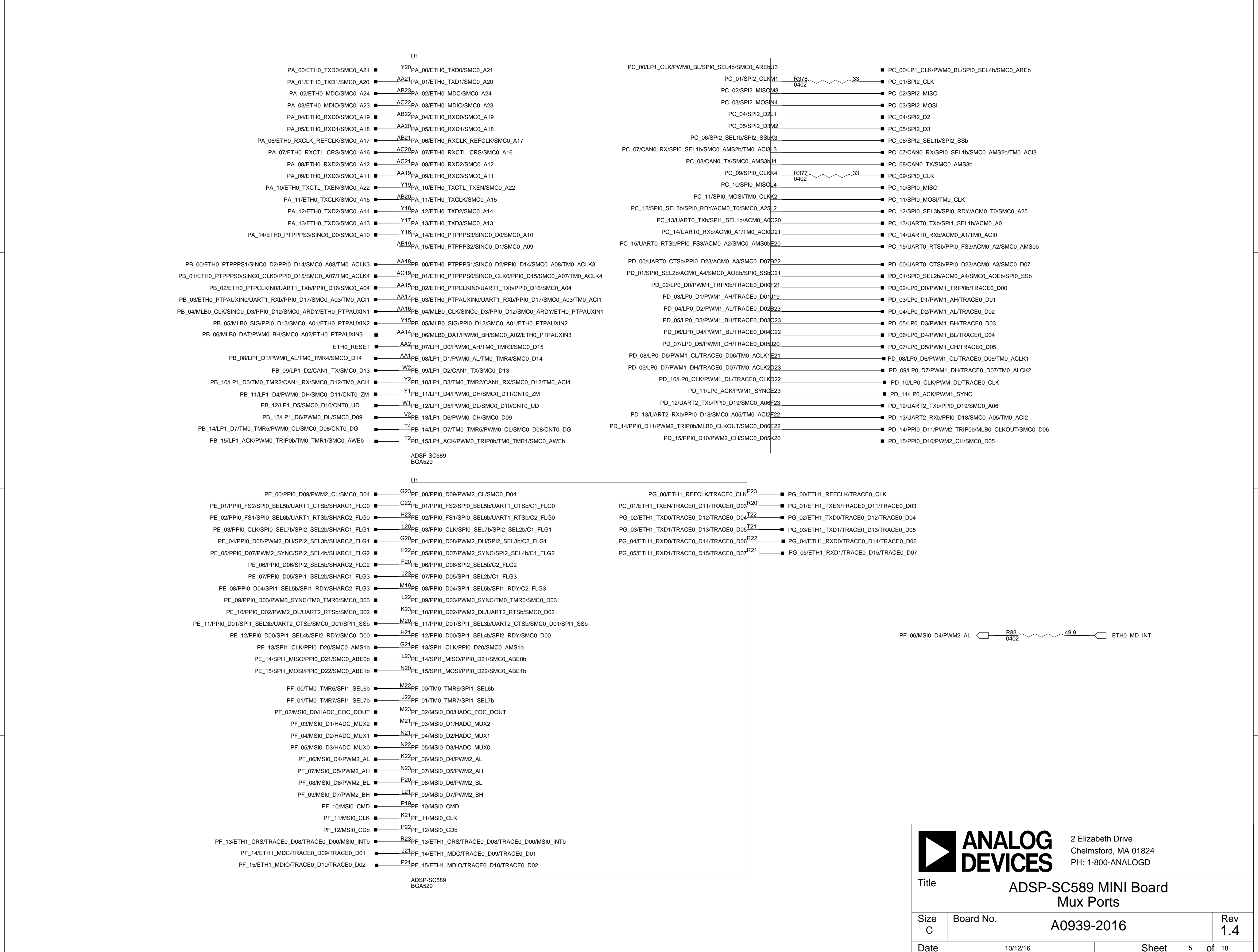

		2 Elizabeth Drive Chelmsford, MA 01824 PH: 1-800-ANALOGD	
		Title ADSP-SC589 MINI Board Mux Ports	
Size C	Board No. A0939-2016	Rev 1.4	
Date 10/12/16	Sheet 5	of 18	

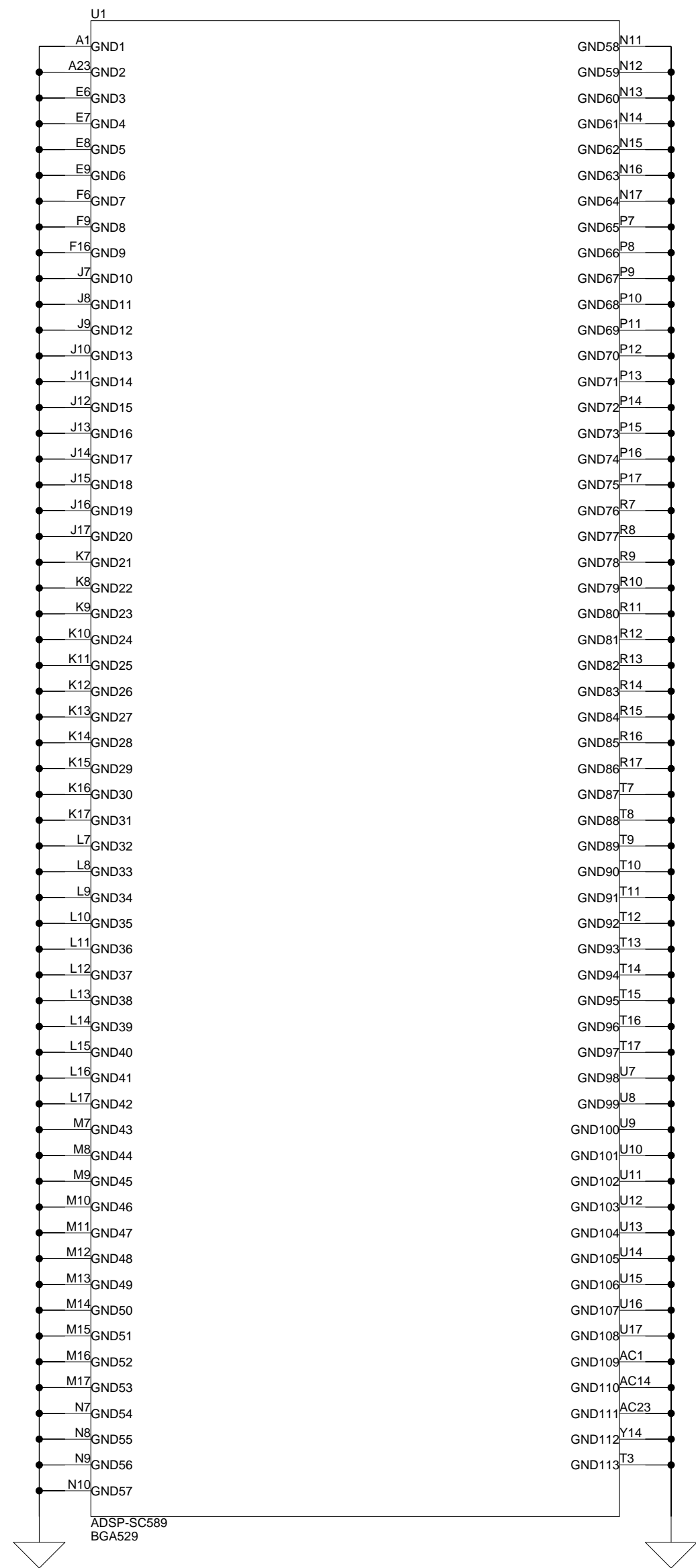
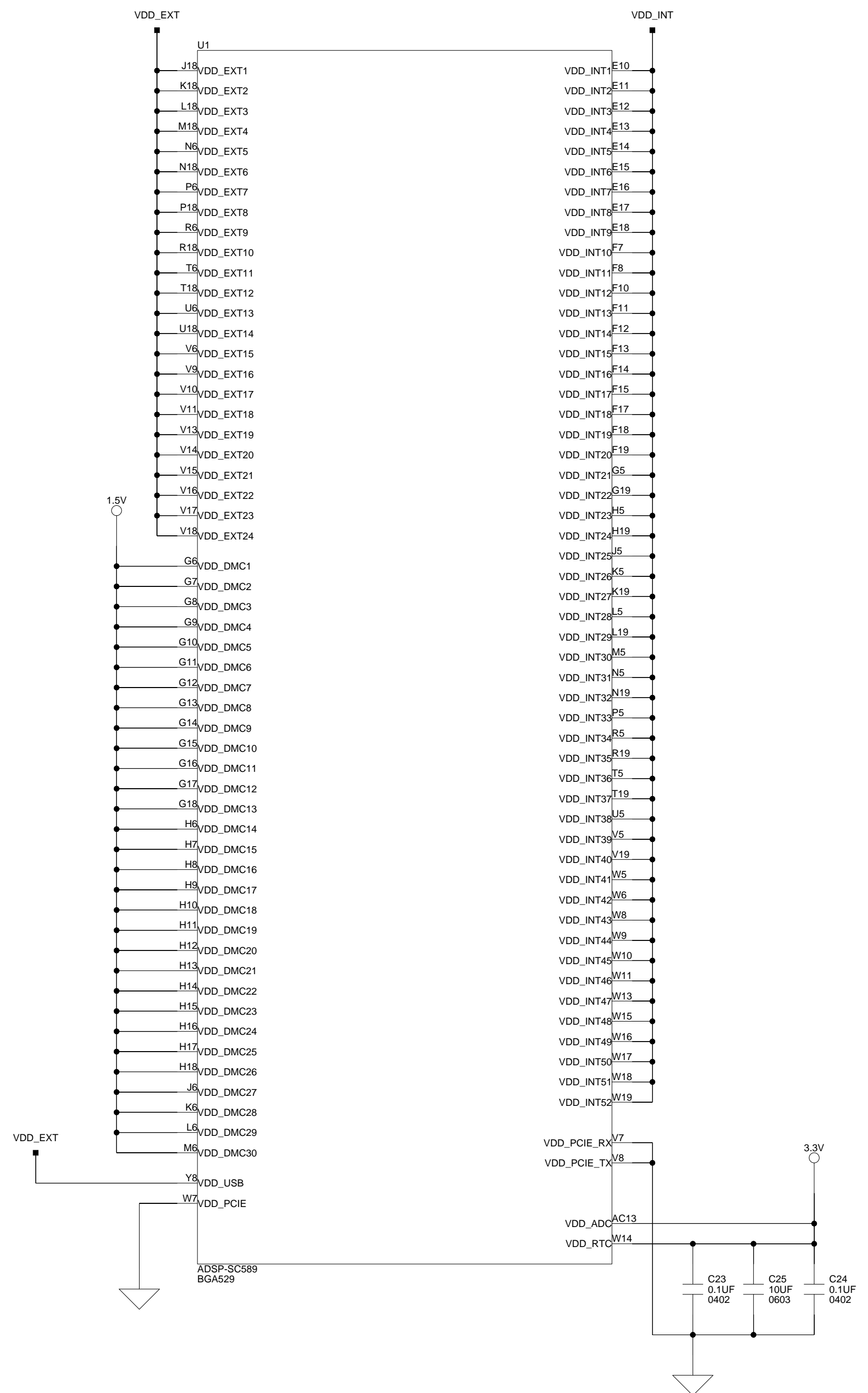

		2 Elizabeth Drive Chelmsford, MA 01824 PH: 1-800-ANALOGD	
		Title ADSP-SC589 MINI Board Processor Power/Ground	
Size C	Board No. A0939-2016	Rev 1.4	
Date 10/12/16	Sheet 6 of 18		

A

B

C

D

1

2

3

4

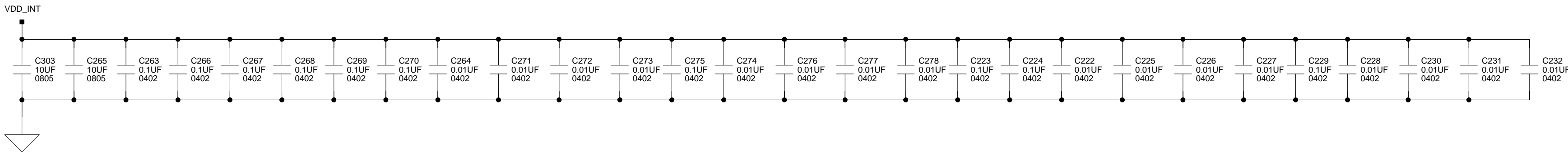
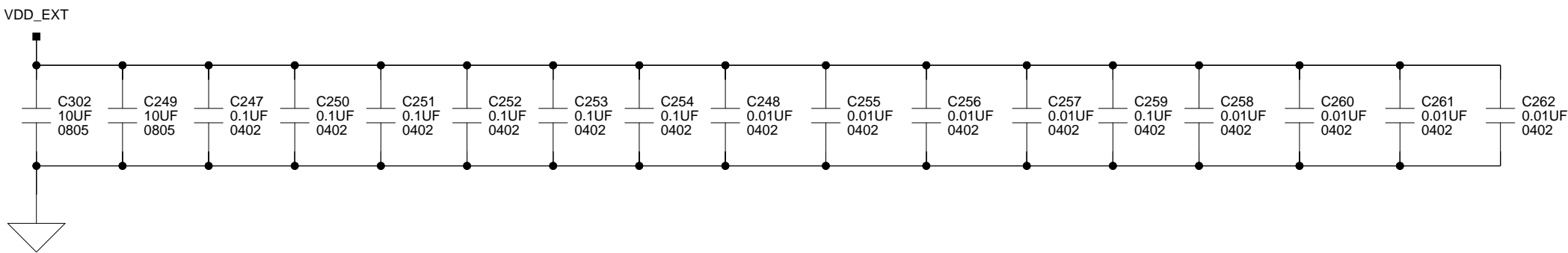
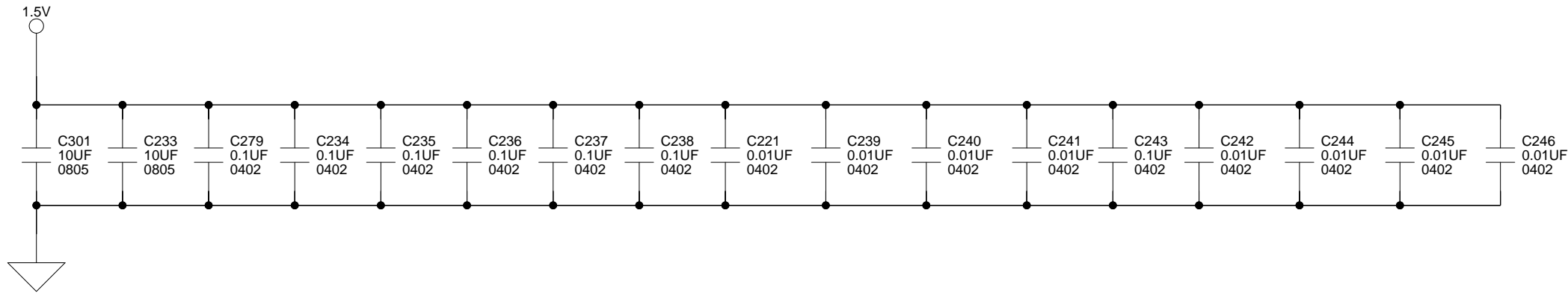

		2 Elizabeth Drive Chelmsford, MA 01824 PH: 1-800-ANALOGD	
Title		ADSP-SC589 MINI Board Proc Bypass Caps	
Size C	Board No.	A0939-2016	Rev 1.4
Date	10/12/16	Sheet	7 of 18

A

B

C

D

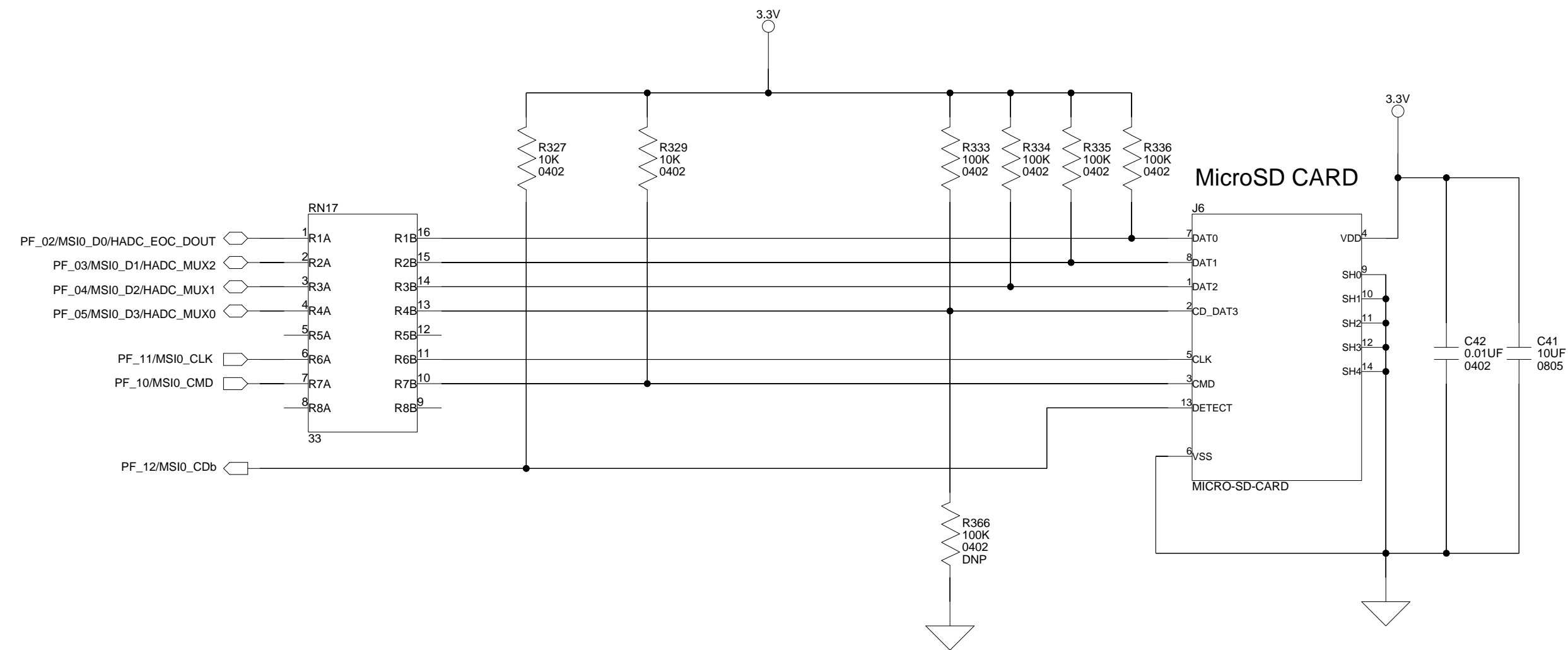

512Mb QUAD SPI FLASH

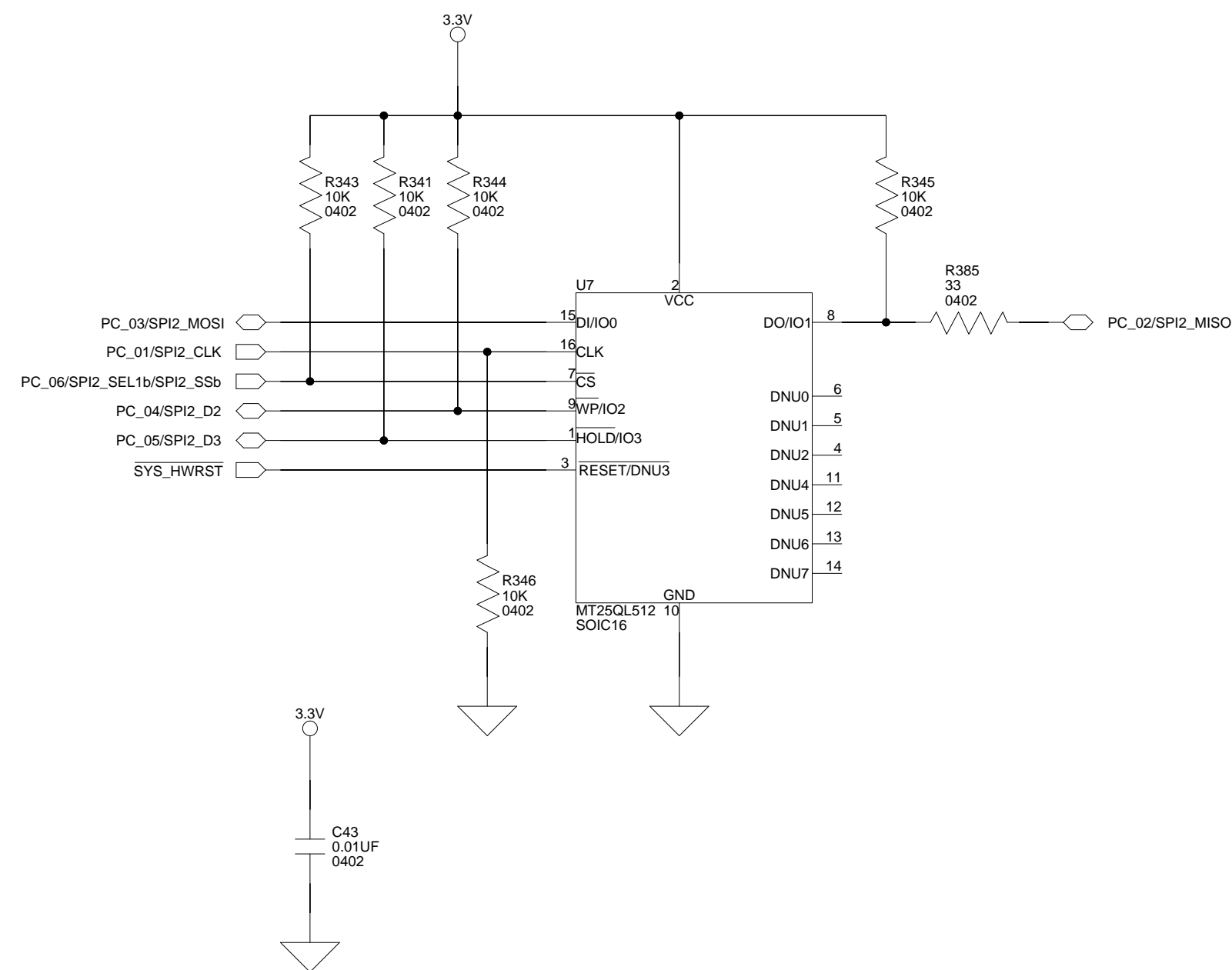

		2 Elizabeth Drive Chelmsford, MA 01824 PH: 1-800-ANALOGD	
		Title ADSP-SC589 MINI Board SPI Flash/SD	
Size C	Board No. A0939-2016	Rev 1.4	
Date 10/12/16	Sheet 8 of 18		Page 4

 S18
SHORTING
JUMPER
DEFAULT=INSTALLED 1-2

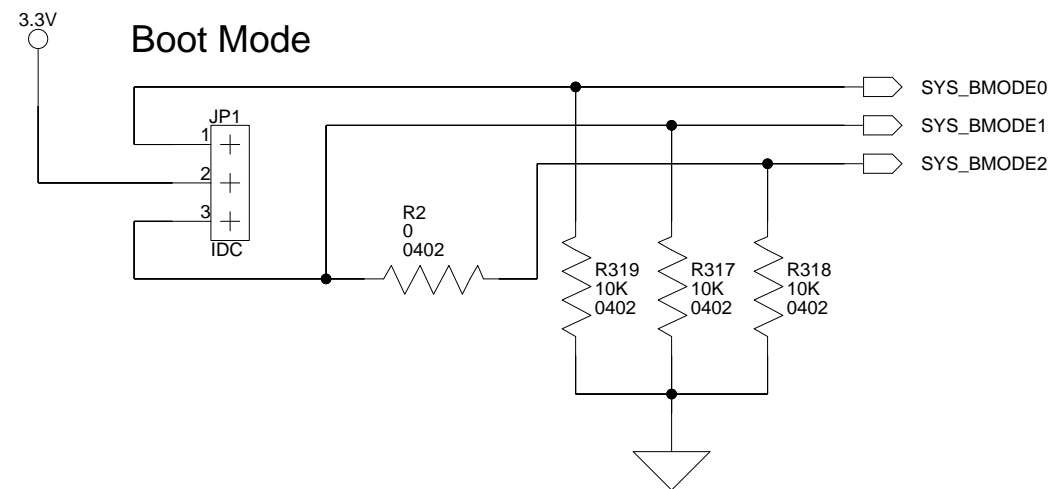

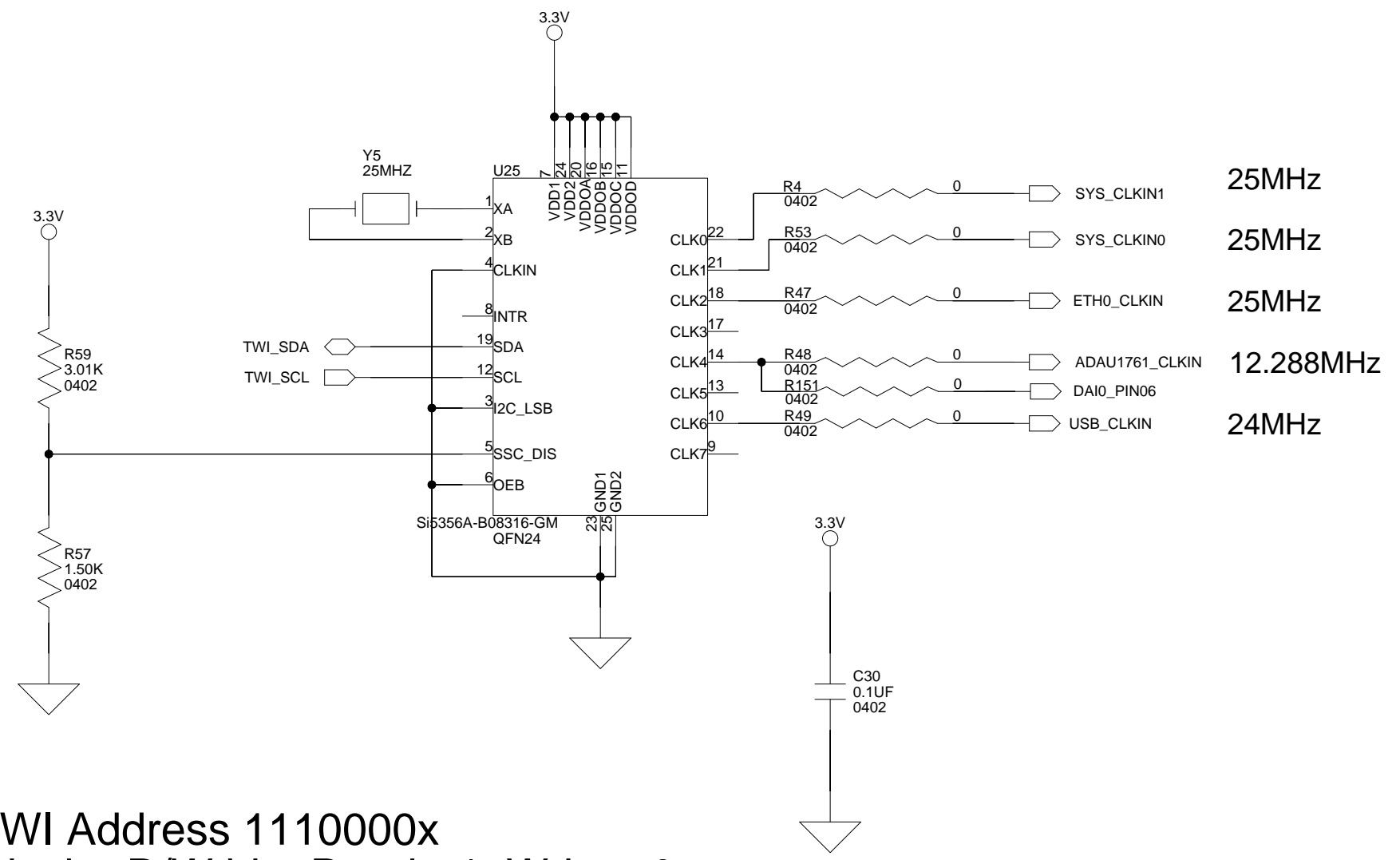

Jumper 1-2: SPI Boot
Jumper 2-3: UART Boot
Jumper Removed: No Boot

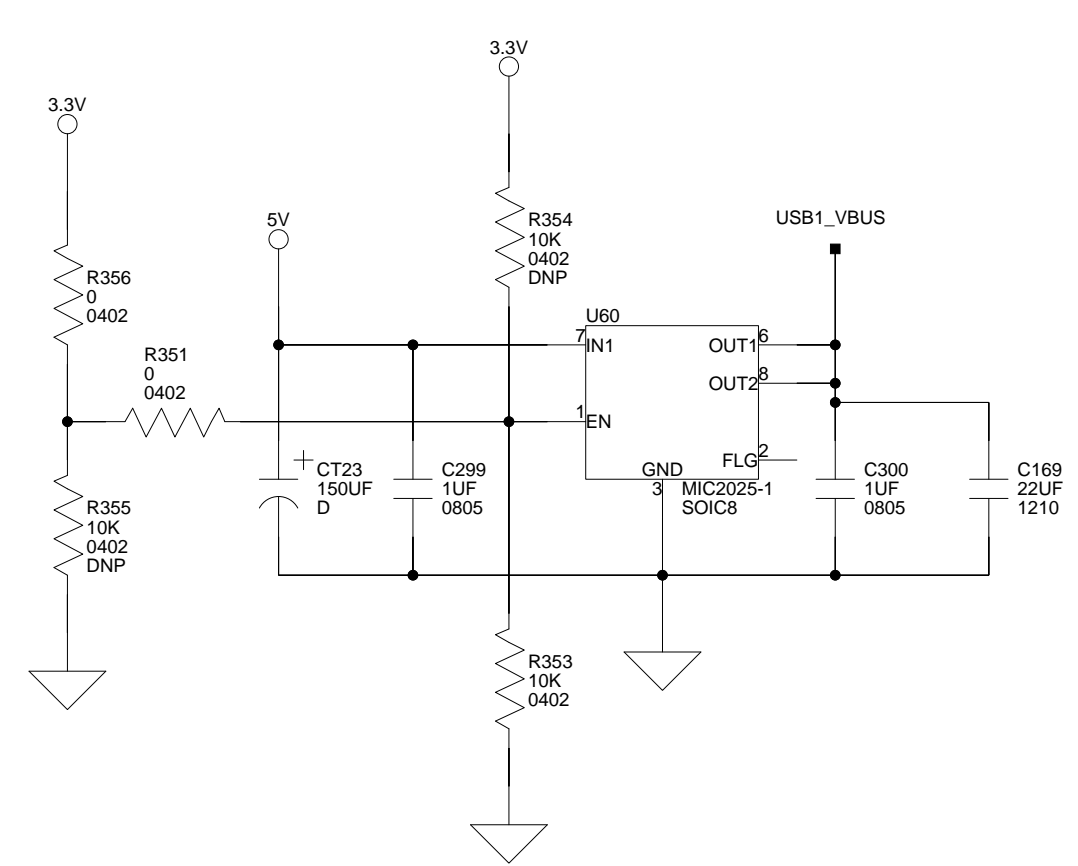
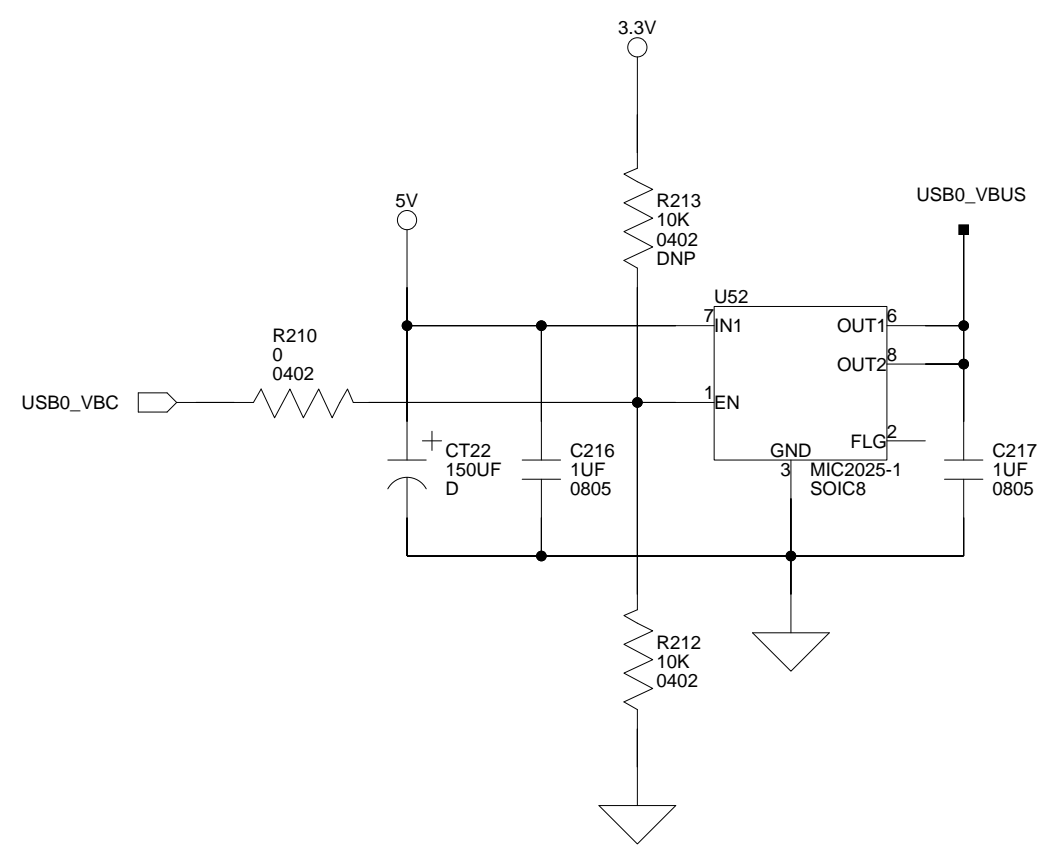
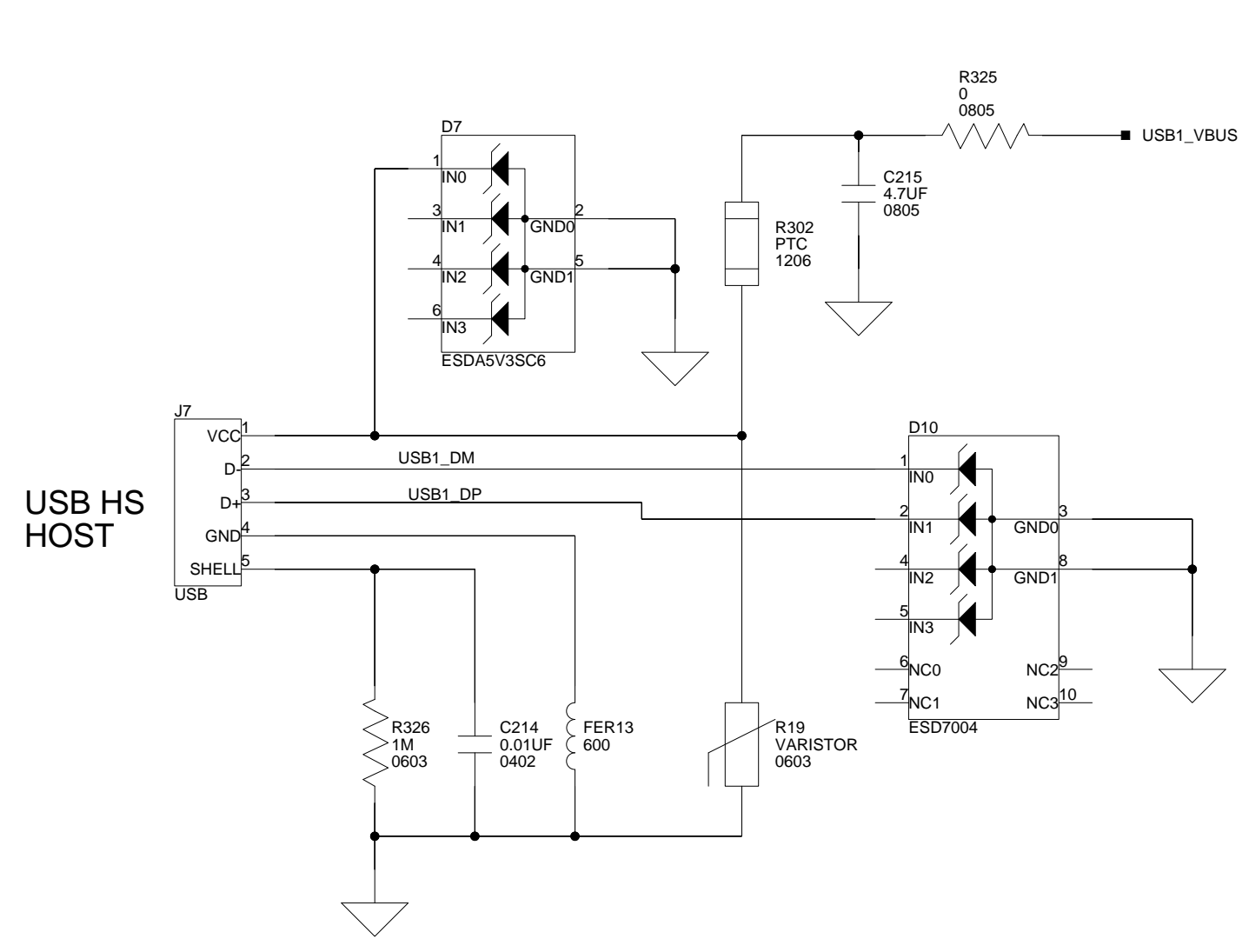
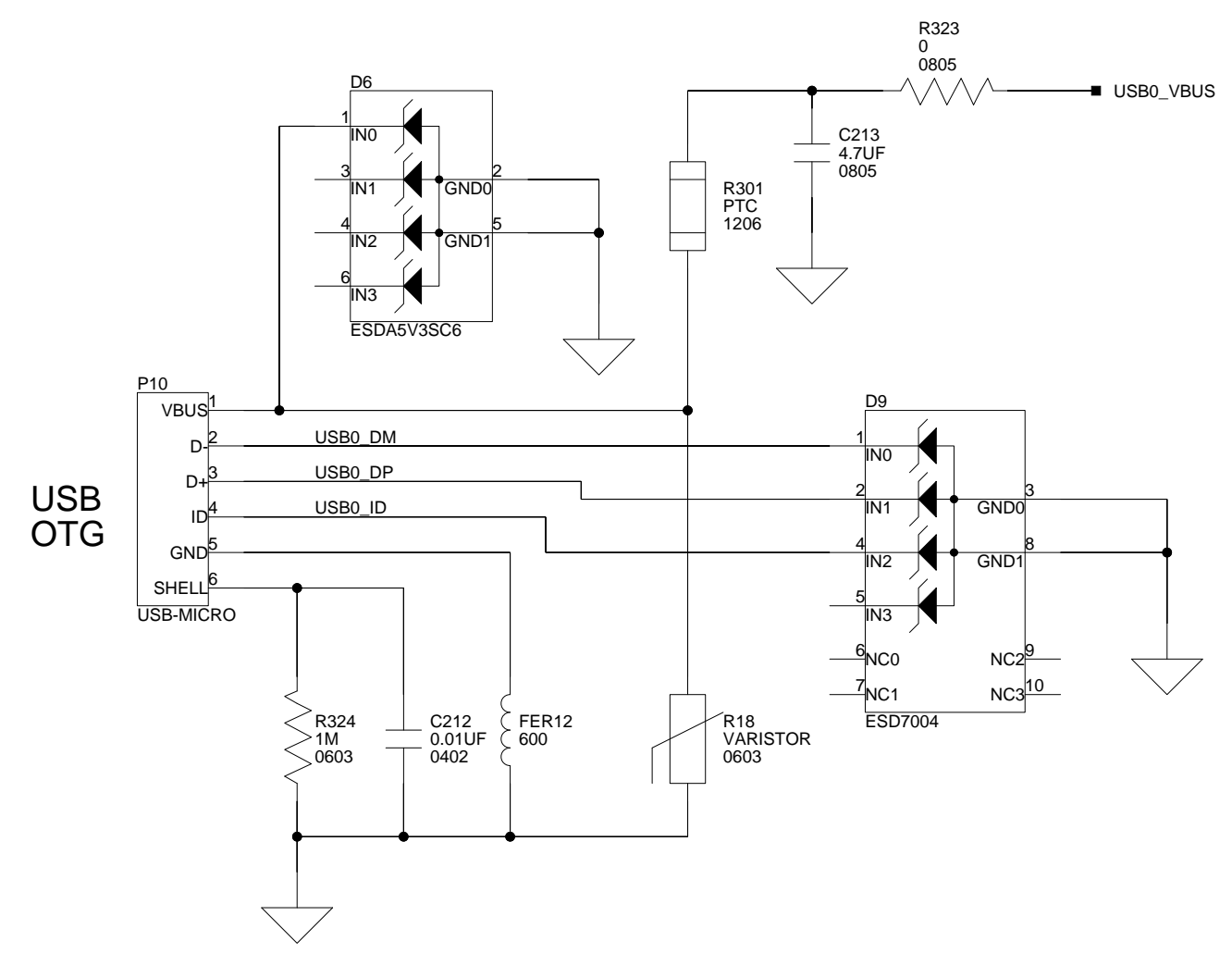

TWI Address 1110000x
x is the R/W bit. Read - 1, Write - 0

		2 Elizabeth Drive Chelmsford, MA 01824 PH: 1-800-ANALOGD	
		Title ADSP-SC589 MINI Board Clocks/Boot Mode	
Size C	Board No. A0939-2016	Rev 1.4	
Date 10/12/16	Sheet 9 of 18		



		2 Elizabeth Drive Chelmsford, MA 01824 PH: 1-800-ANALOGD	
		Title ADSP-SC589 MINI Board USB	
Size C	Board No. A0939-2016	Rev 1.4	
Date 10/12/16	Sheet 10 of 18		

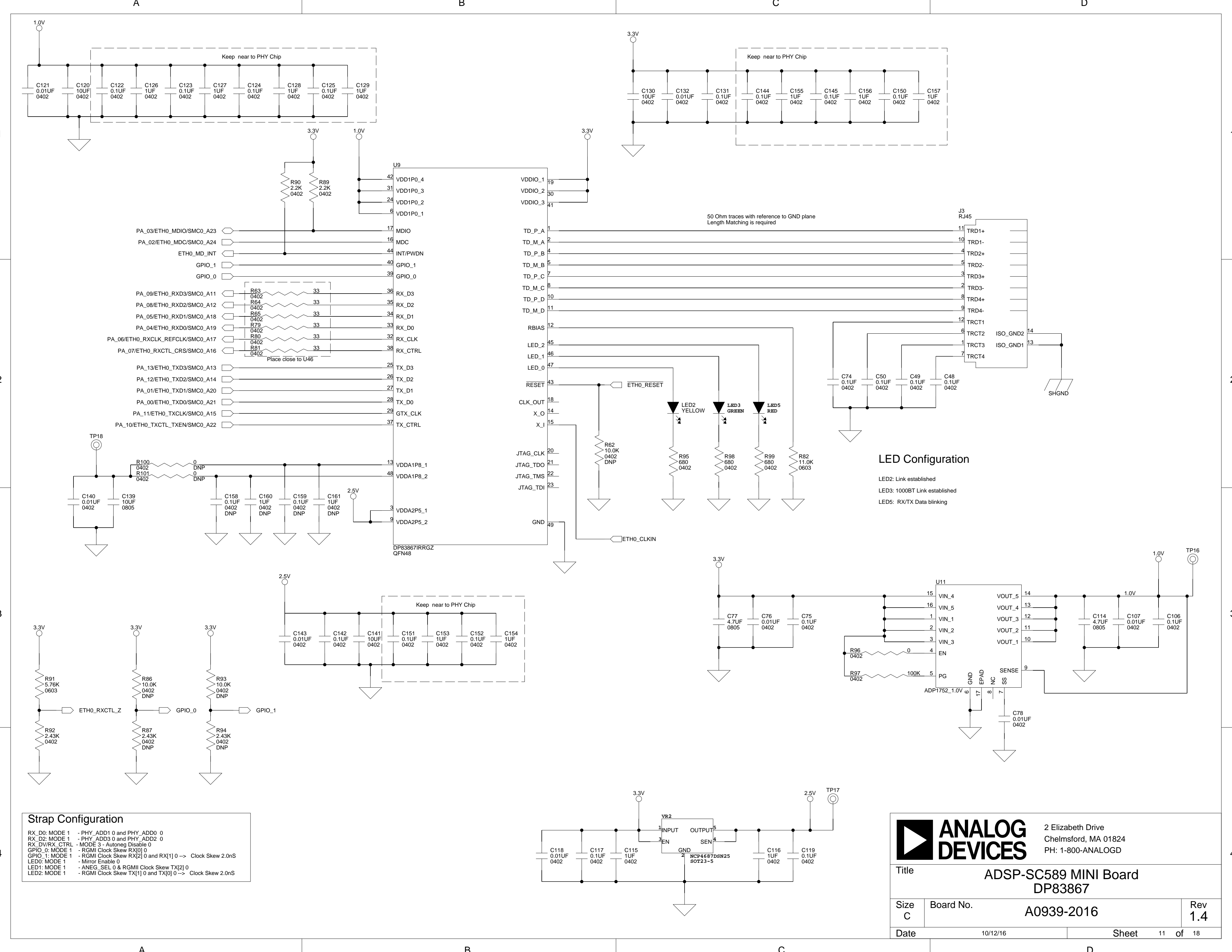

Strap Configuration

RX_D0: MODE 1	- PHY_ADD1 0 and PHY_ADD0 0
RX_D2: MODE 1	- PHY_ADD3 0 and PHY_ADD2 0
RX_DV/RX_CTRL	- MODE 3 - Autoneg Disable 0
GPIO_0: MODE 1	- RGMII Clock Skew RX[0] 0
GPIO_1: MODE 1	- RGMII Clock Skew RX[2] 0 and RX[1] 0 --> Clock Skew 2.0nS
LED0: MODE 1	- Mirror Enable 0
LED1: MODE 1	- ANEG_SEL 0 & RGMII Clock Skew TX[2] 0
LED2: MODE 1	- RGMII Clock Skew TX[1] 0 and TX[0] 0 --> Clock Skew 2.0nS

ANALOG DEVICES
 2 Elizabeth Drive
 Chelmsford, MA 01824
 PH: 1-800-ANALOGD

Title: **ADSP-SC589 MINI Board DP83867**

Size C	Board No. A0939-2016	Rev 1.4
Date	10/12/16	Sheet 11 of 18

USB to UART

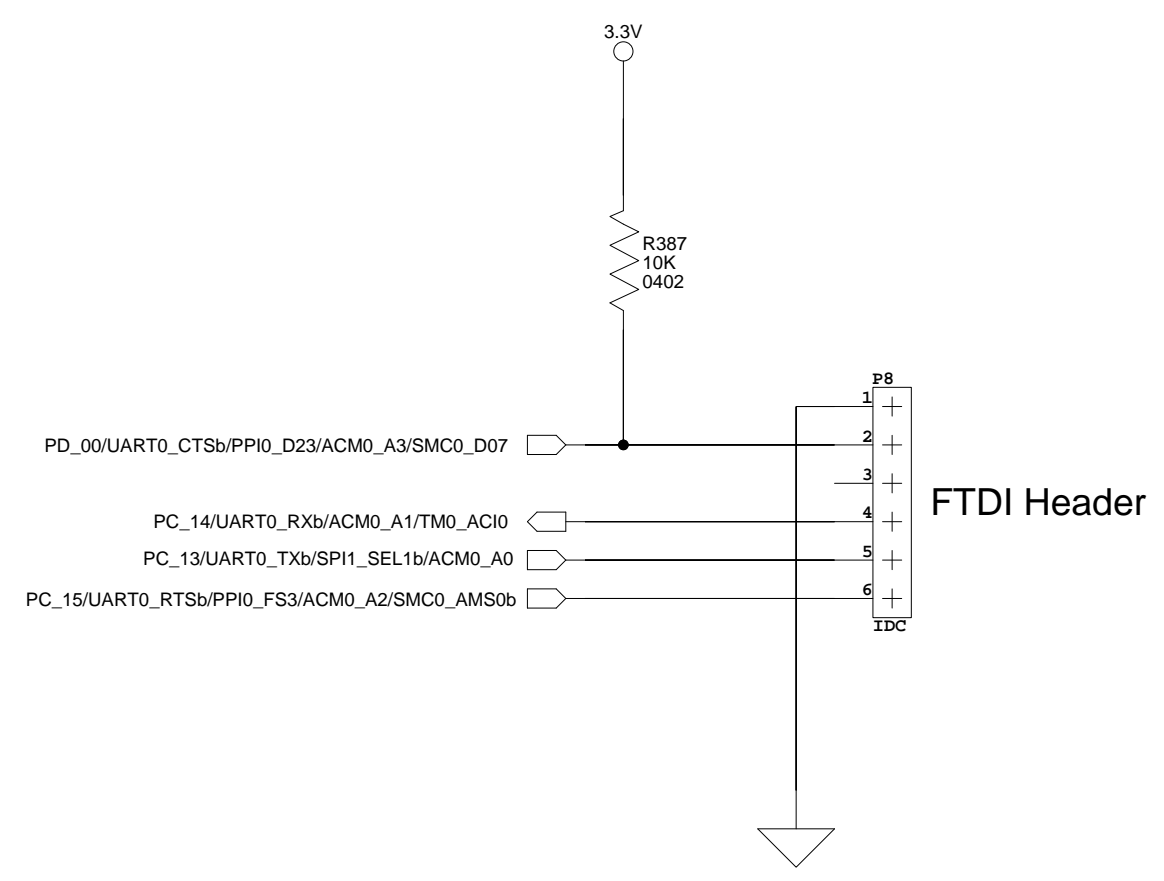

DEBUG

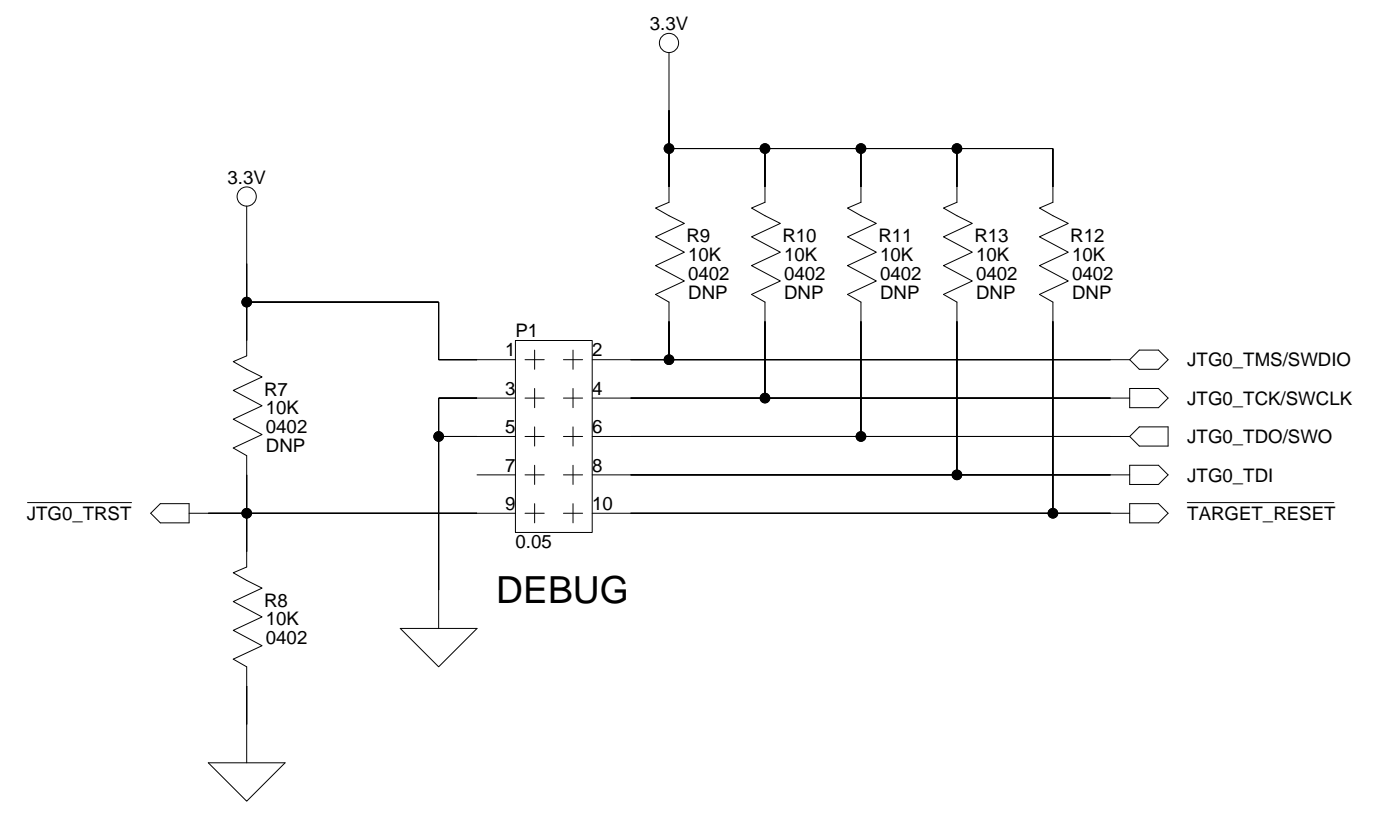

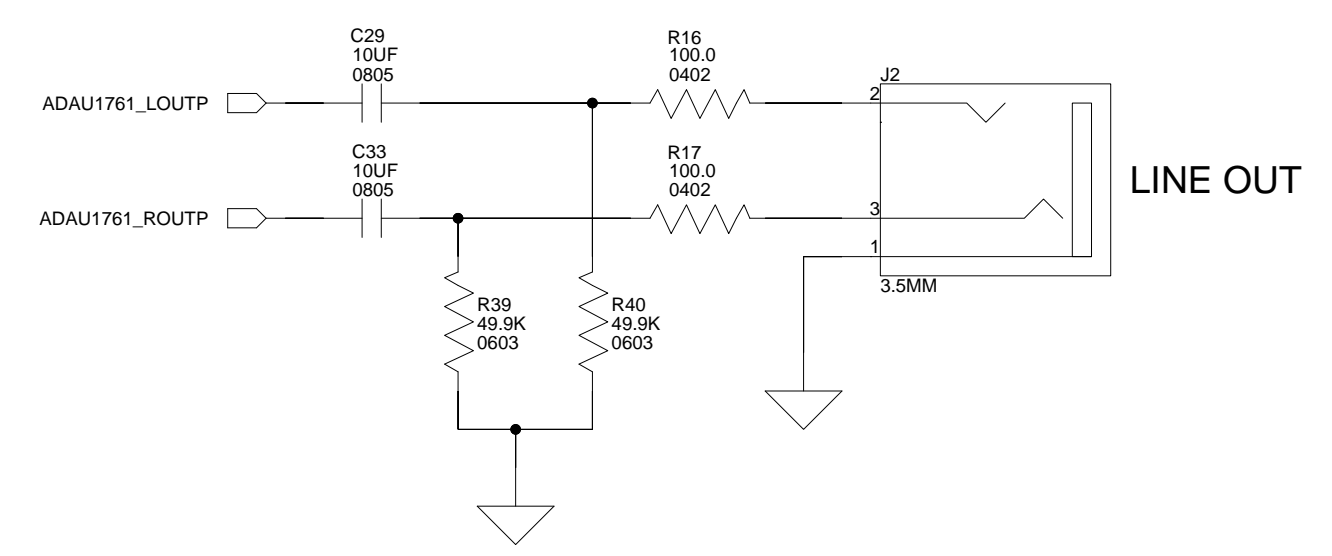
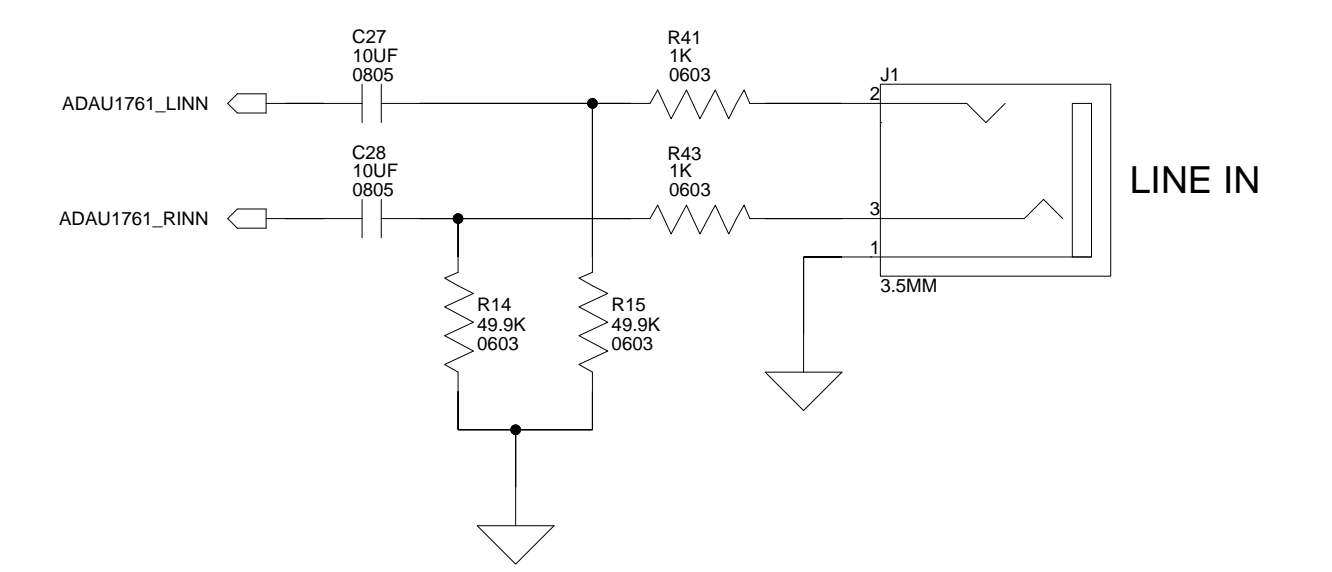
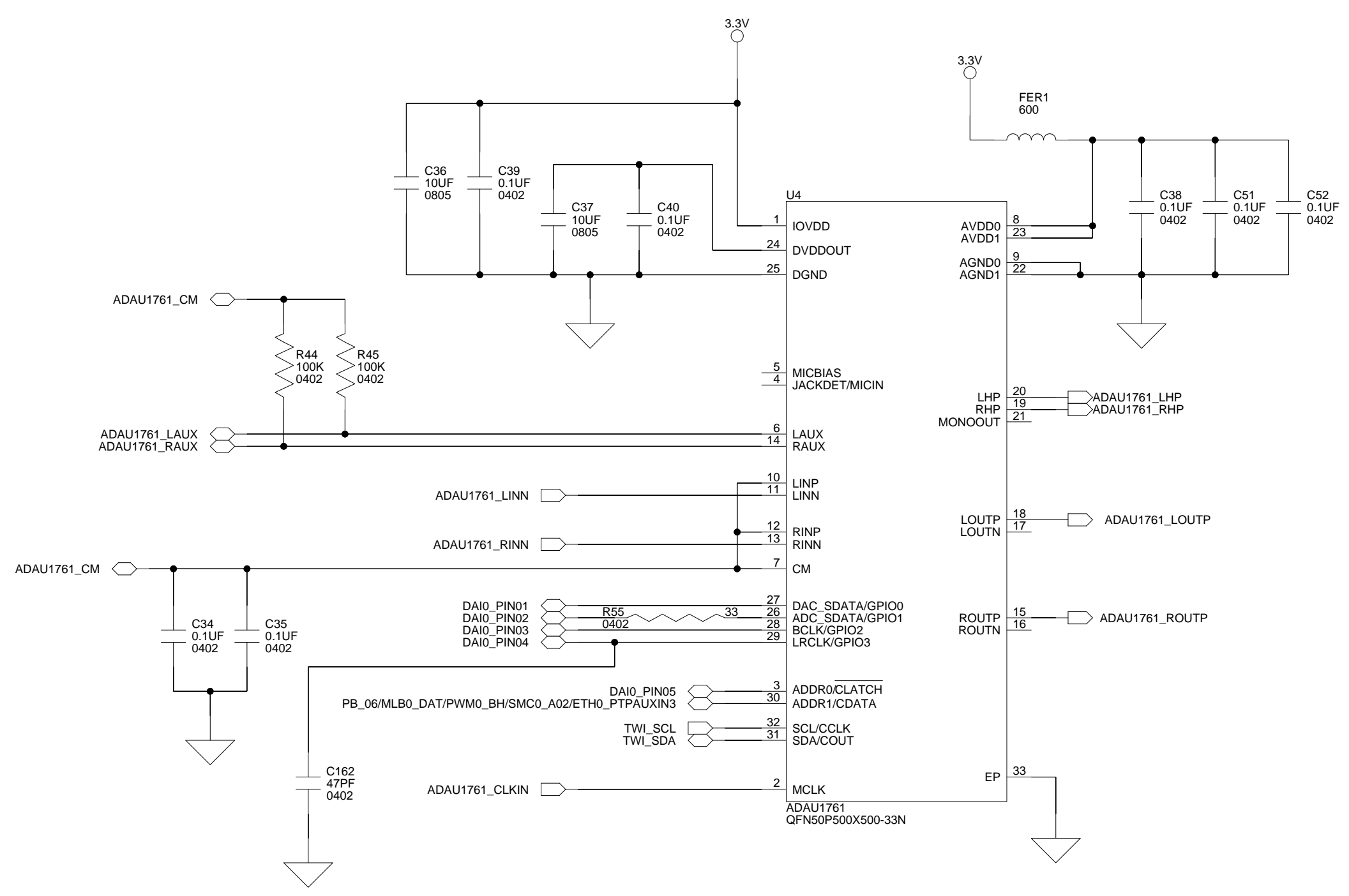
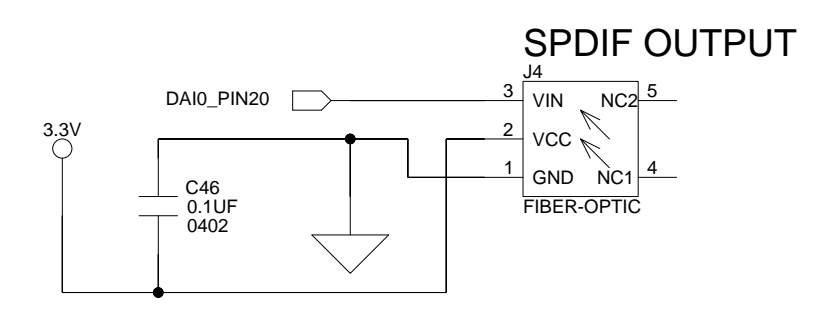
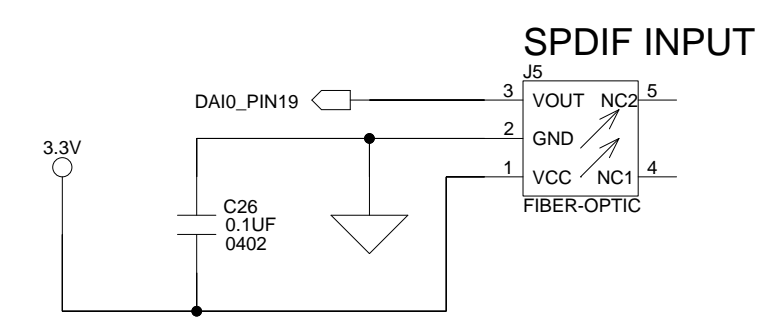
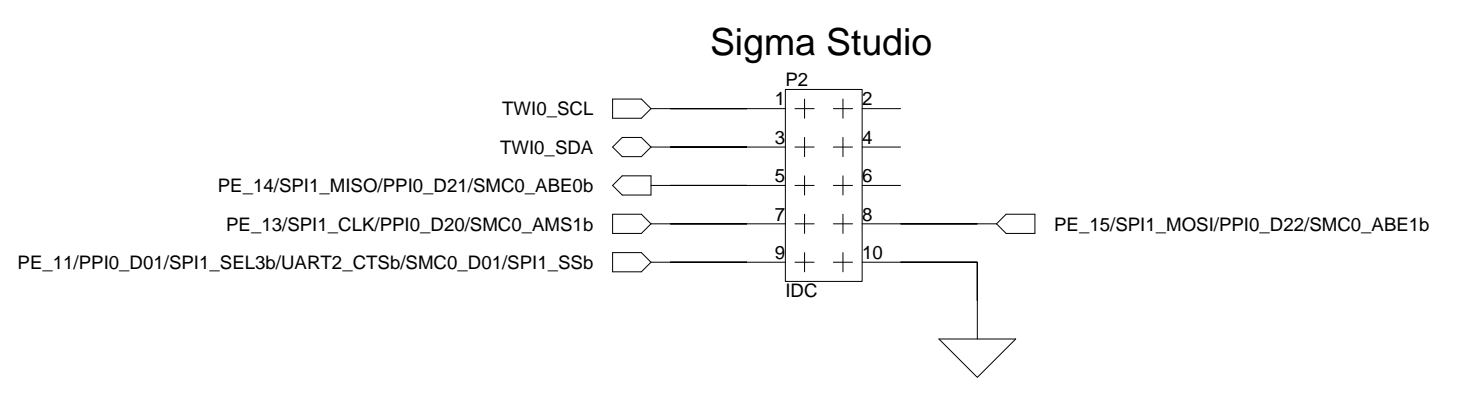

		2 Elizabeth Drive Chelmsford, MA 01824 PH: 1-800-ANALOGD	
		Title ADSP-SC589 MINI Board UART/JTAG	
Size C	Board No. A0939-2016	Rev 1.4	
Date 10/12/16	Sheet 12 of 18		

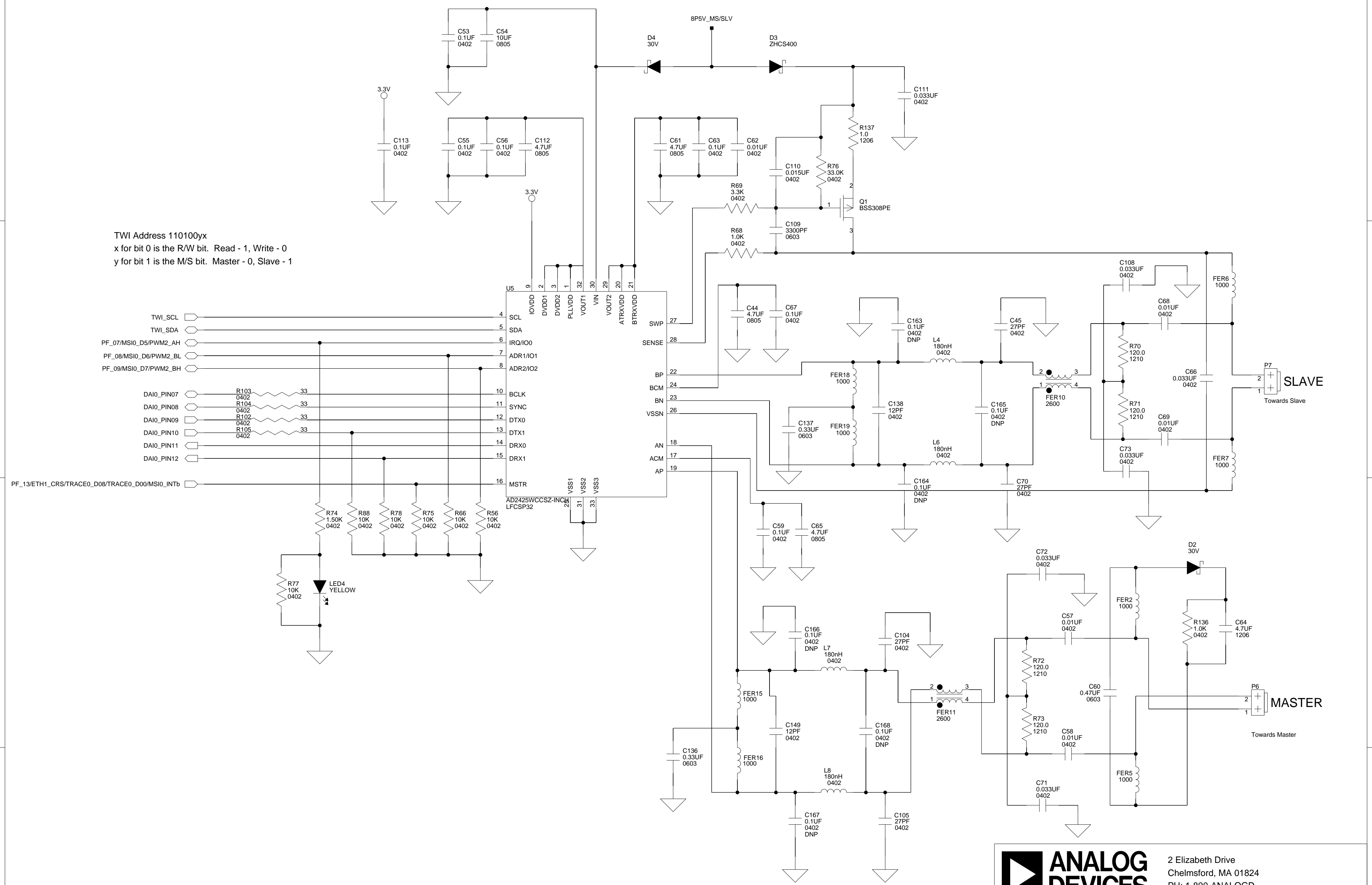

		2 Elizabeth Drive Chelmsford, MA 01824 PH: 1-800-ANALOGD	
		Title ADSP-SC589 MINI Board ADAU1761	
Size C	Board No. A0939-2016	Rev 1.4	
Date 10/12/16	Sheet 13 of 18		

TWI Address 110100yx
 x for bit 0 is the R/W bit. Read - 1, Write - 0
 y for bit 1 is the M/S bit. Master - 0, Slave - 1



		2 Elizabeth Drive Chelmsford, MA 01824 PH: 1-800-ANALOGD	
		Title ADSP-SC589 MINI Board A2B Master/Slave Node	
Size C	Board No. A0939-2016	Rev 1.4	
Date 10/12/16	Sheet 14 of 18		

A

B

C

D

1

1

2

2

3

3

4

4

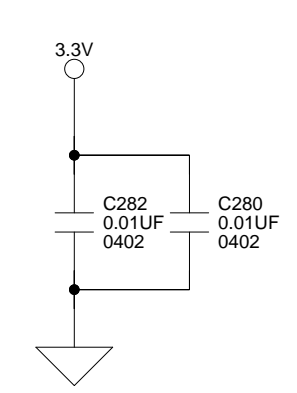
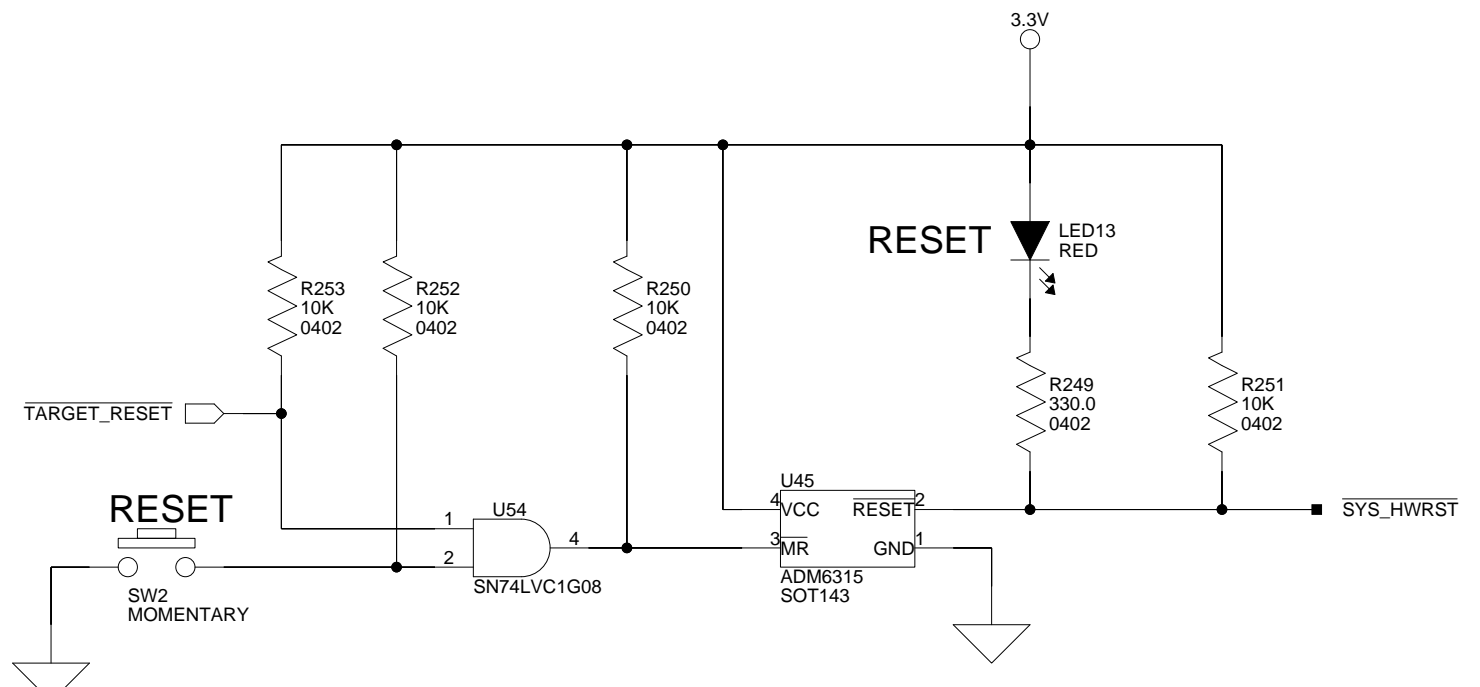
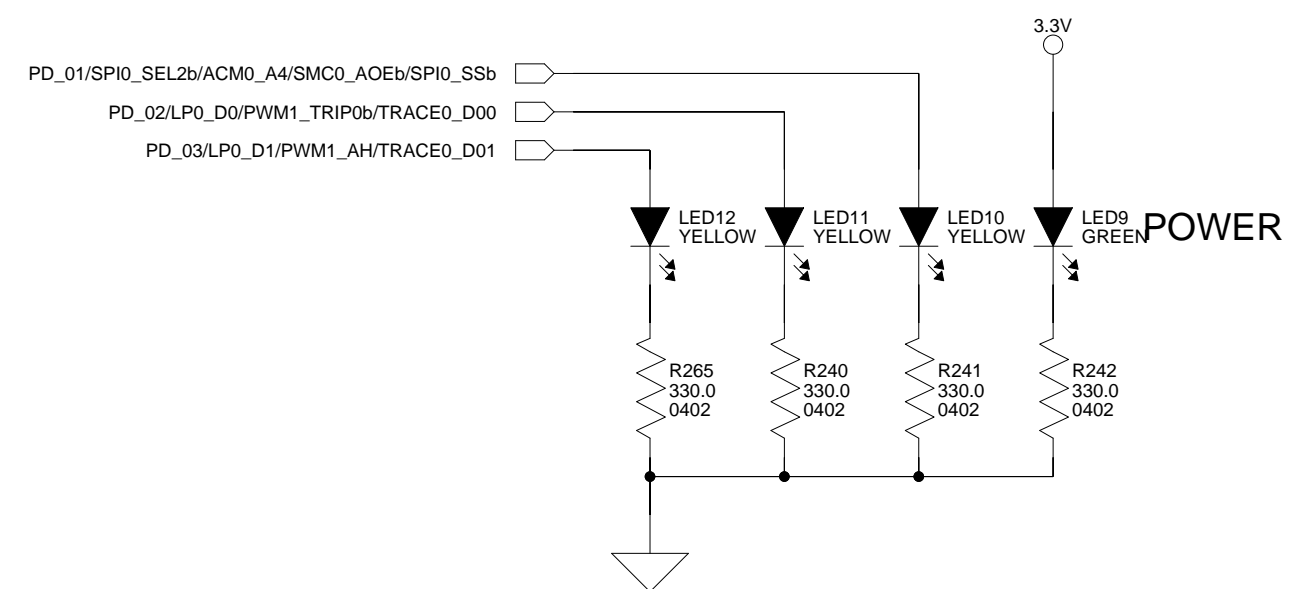
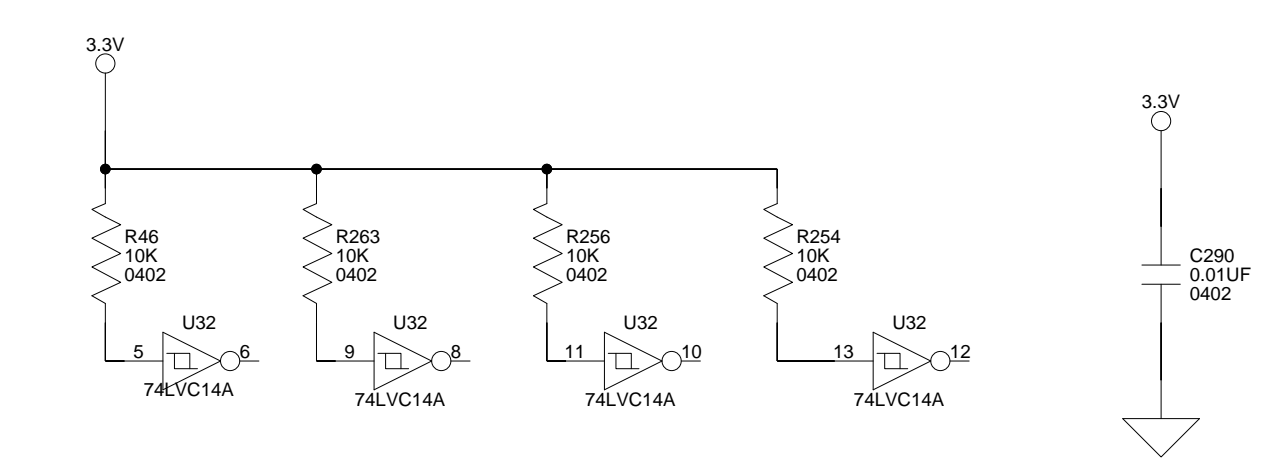
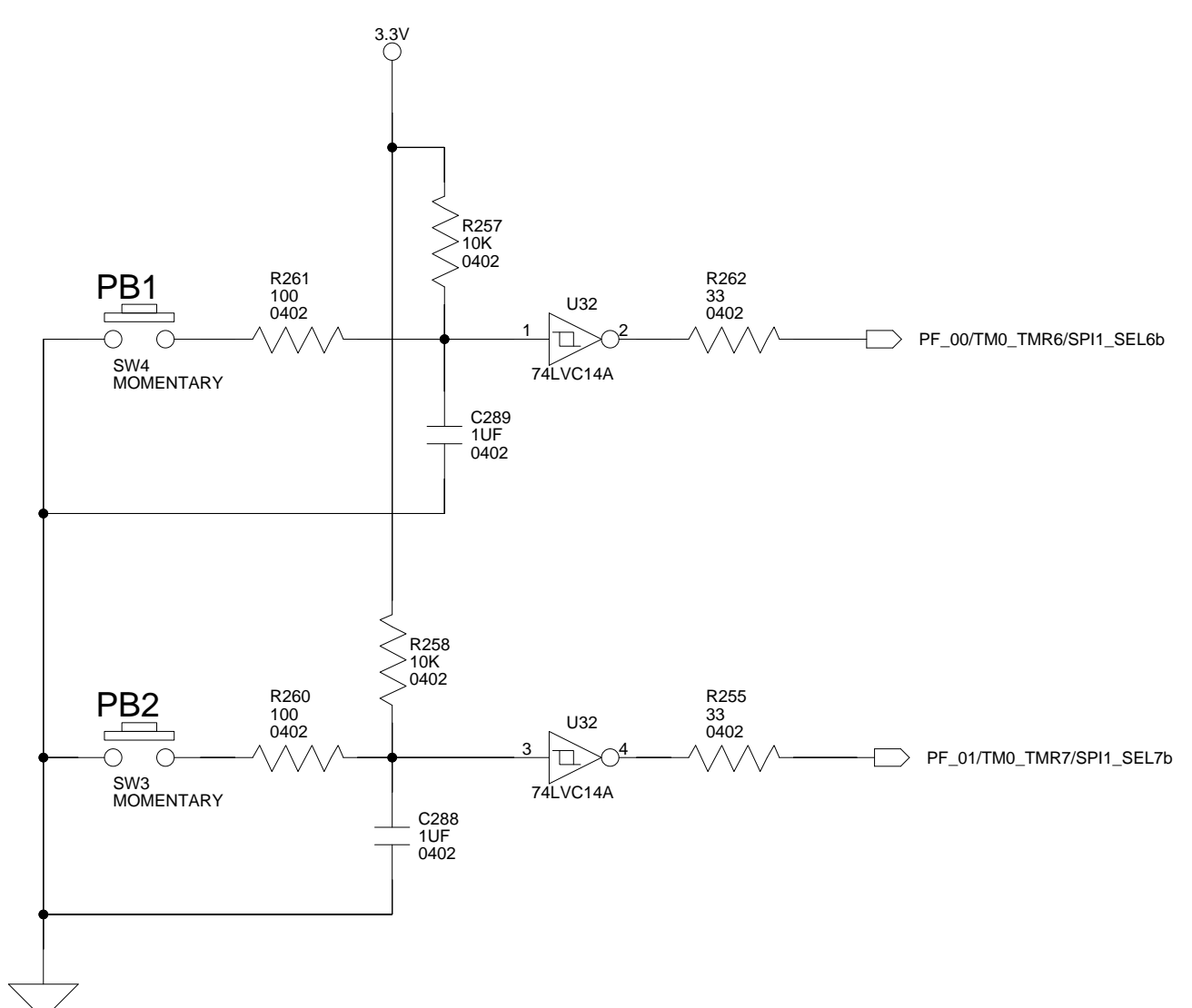

		2 Elizabeth Drive Chelmsford, MA 01824 PH: 1-800-ANALOGD	
		Title ADSP-SC589 MINI Board LEDs/Switches/Reset	
Size C	Board No. A0939-2016	Rev 1.4	
Date 10/12/16	Sheet 15 of 18		

Expansion Ports

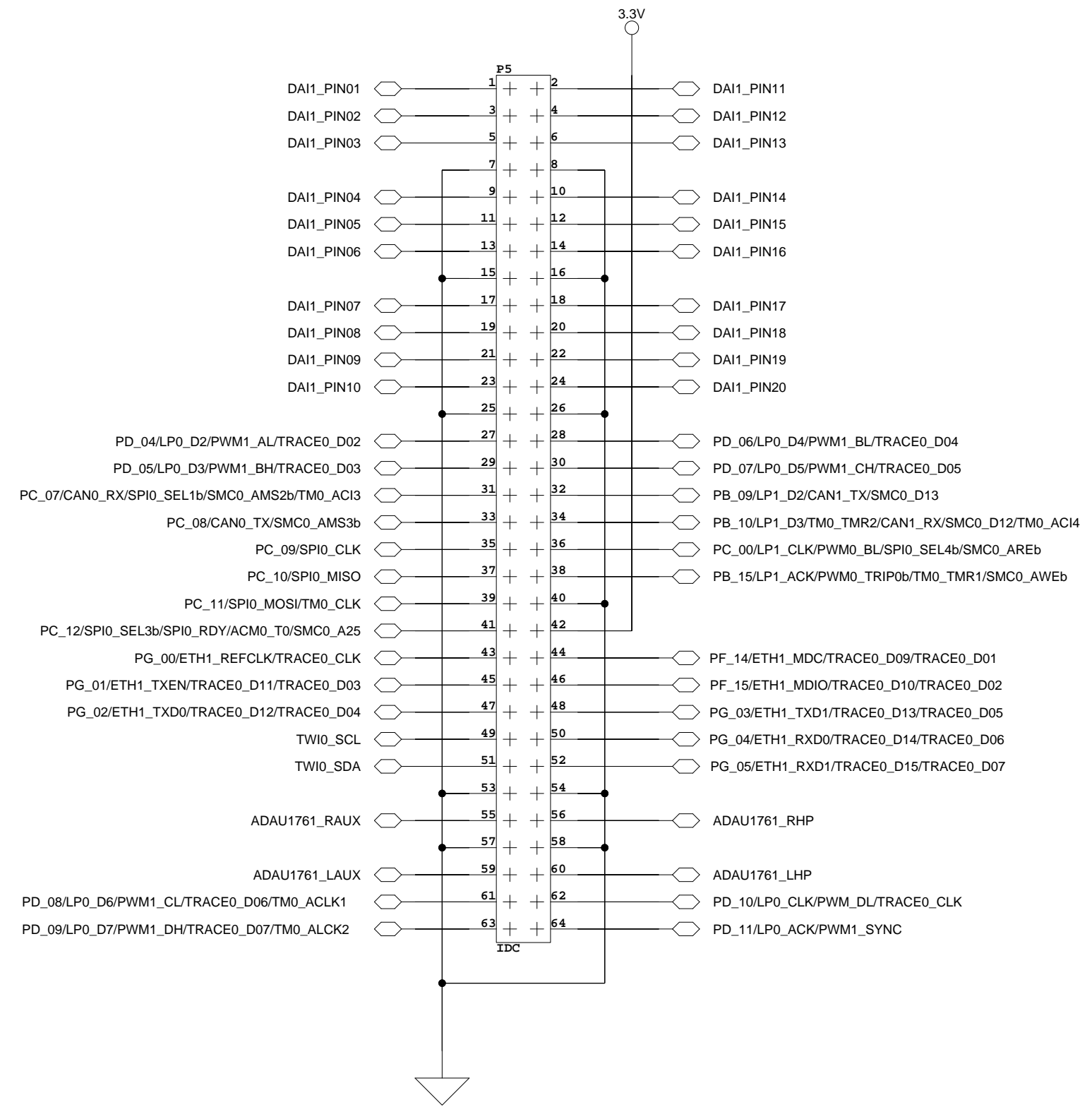
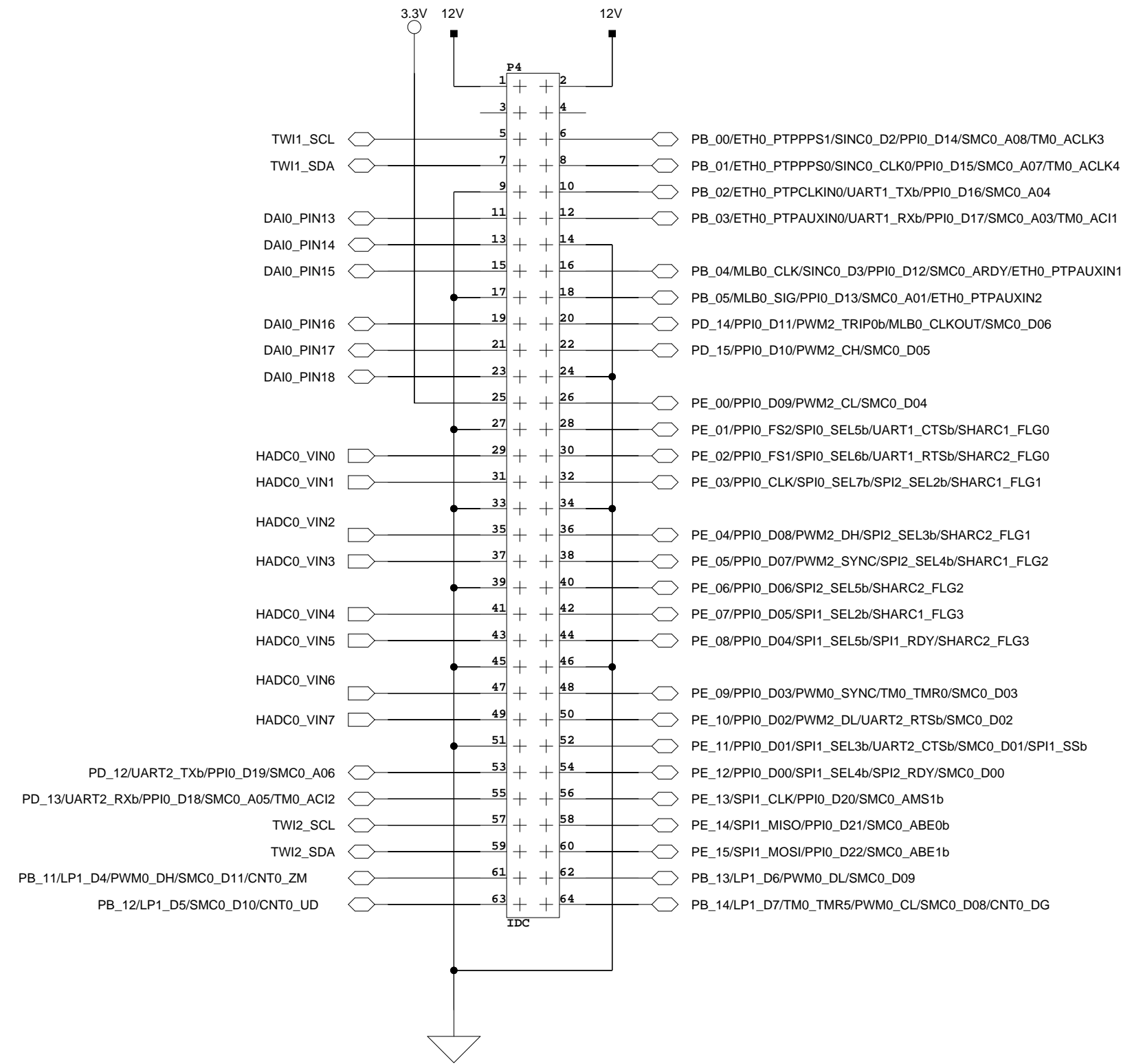

Expansion Board ID Pins

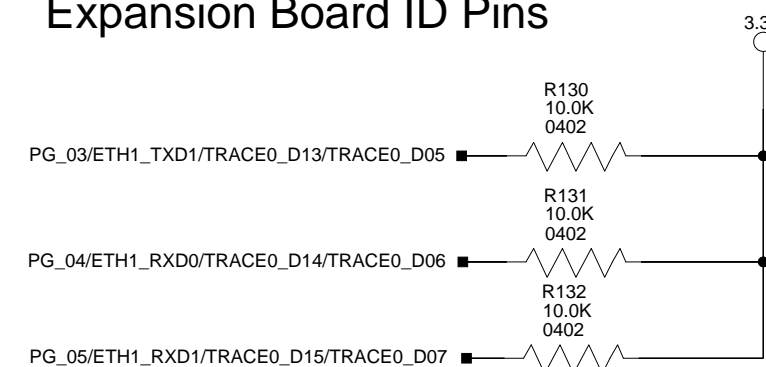

		2 Elizabeth Drive Chelmsford, MA 01824 PH: 1-800-ANALOGD	
		Title ADSP-SC589 MINI Board Expansion Ports	
Size C	Board No. A0939-2016	Rev 1.4	
Date 10/12/16	Sheet 16	of 18	

A

B

C

D

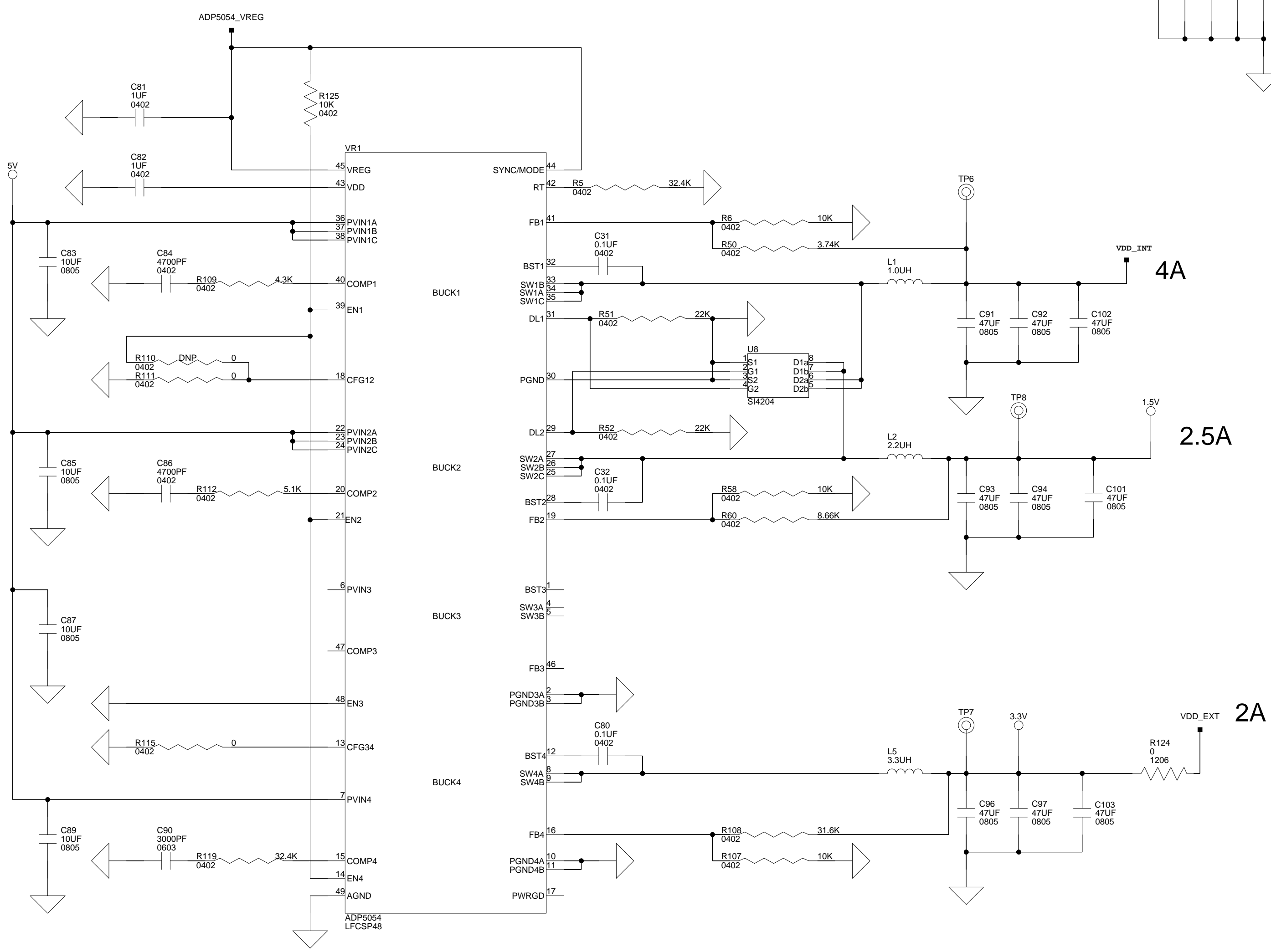

GND Test Points are scattered on PCB for Test Measurement Purposes.
 LABEL "GND" ON ALL TPs

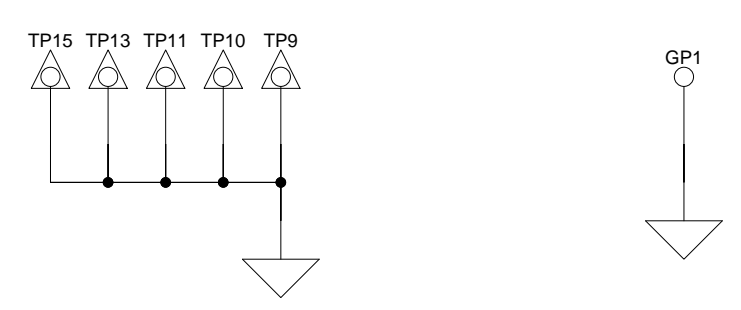

		2 Elizabeth Drive Chelmsford, MA 01824 PH: 1-800-ANALOGD	
		Title ADSP-SC589 MINI Board Power	
Size C	Board No. A0939-2016	Rev 1.4	
Date 10/12/16	Sheet 17 of 18		

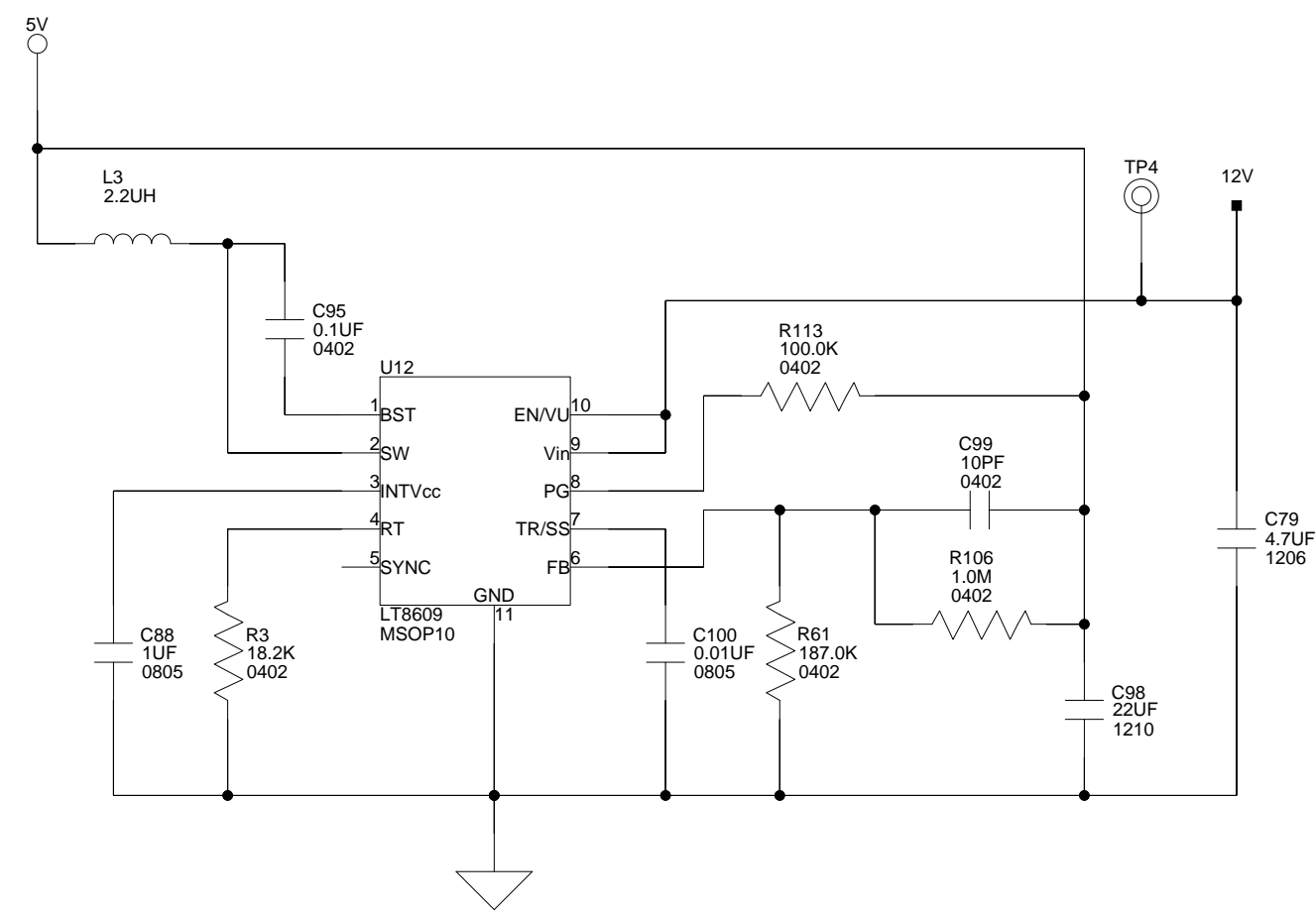
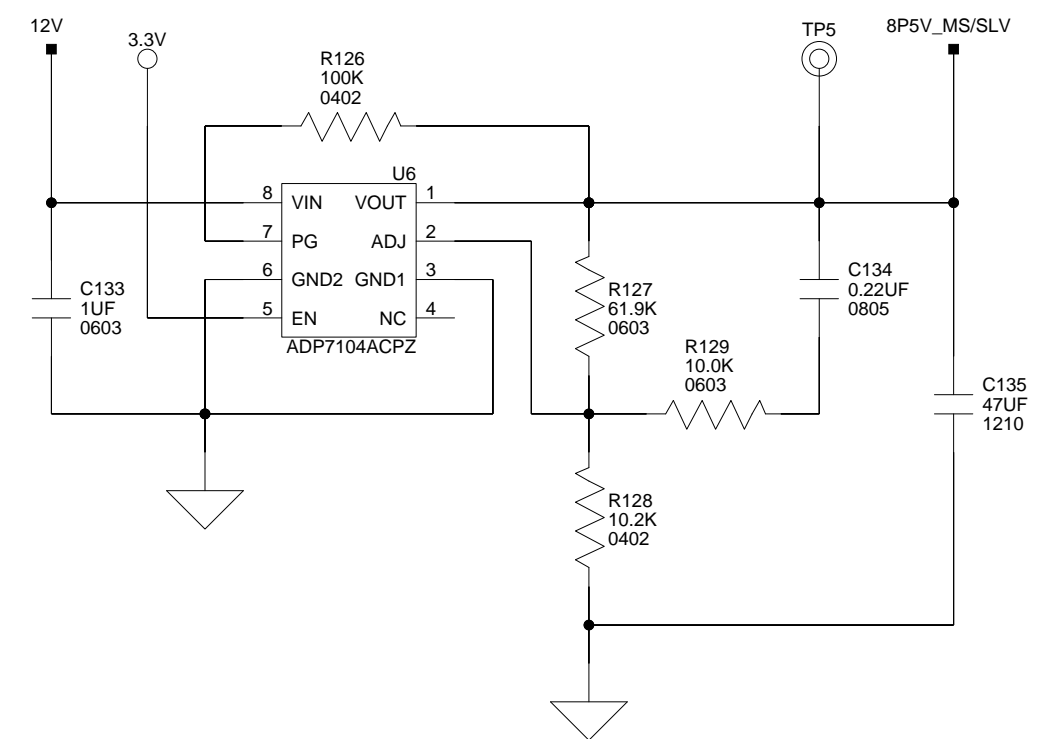
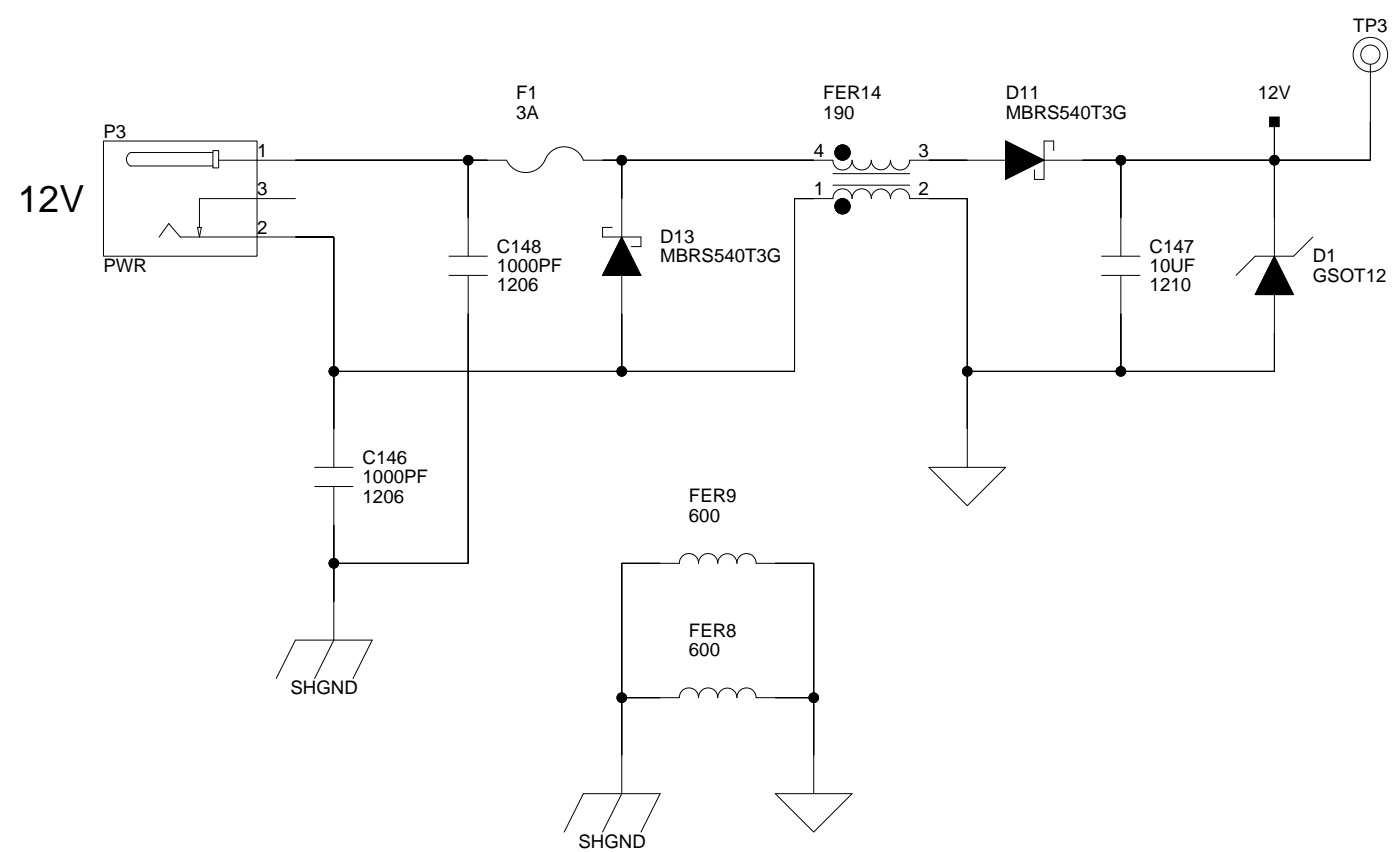

		2 Elizabeth Drive Chelmsford, MA 01824 PH: 1-800-ANALOGD	
		Title ADSP-SC589 MINI Board A2B Power	
Size C	Board No. A0939-2016	Rev 1.4	
Date 10/12/16	Sheet 18 of 18		