

EXTRUSION

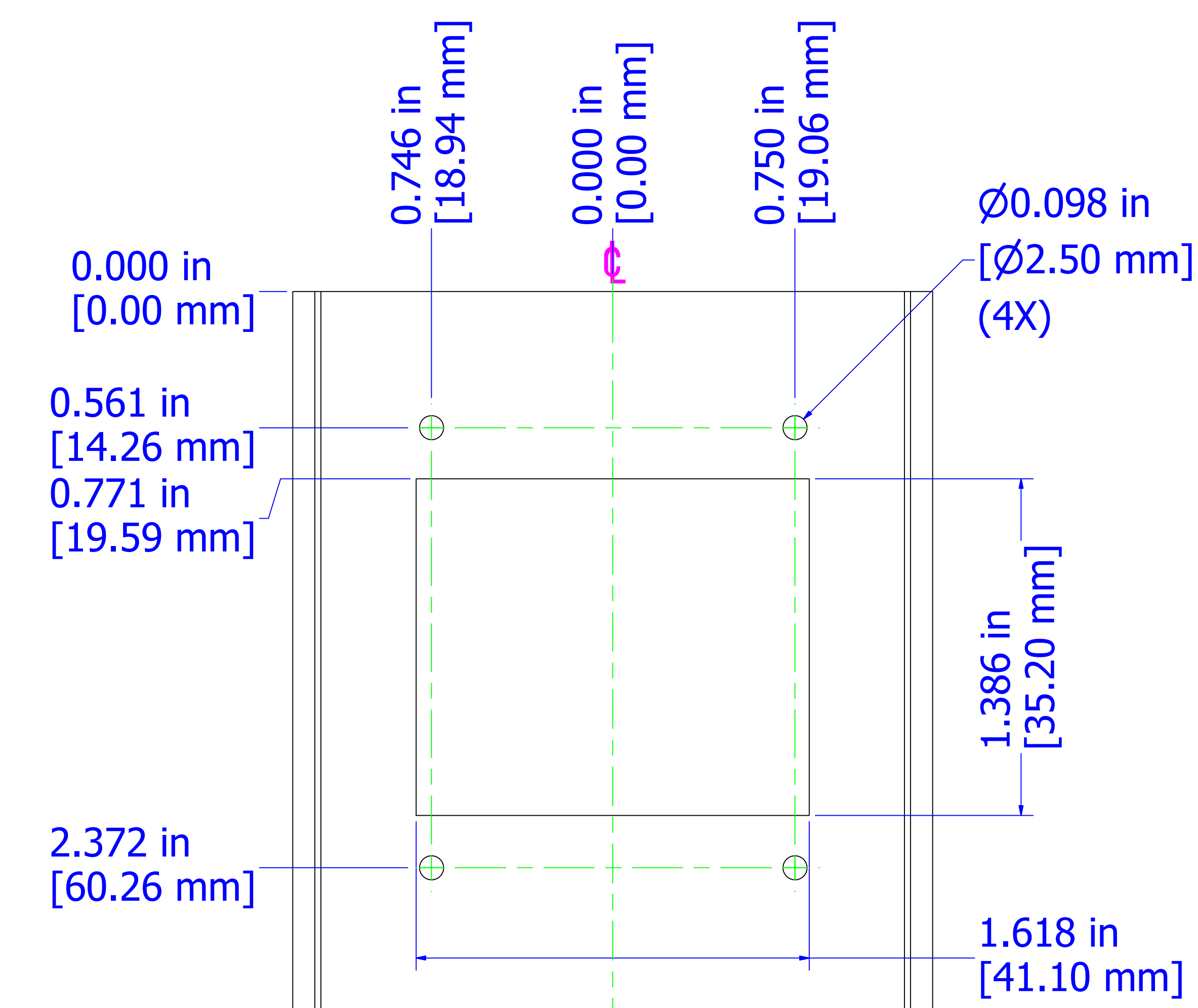

BELLY PLATE

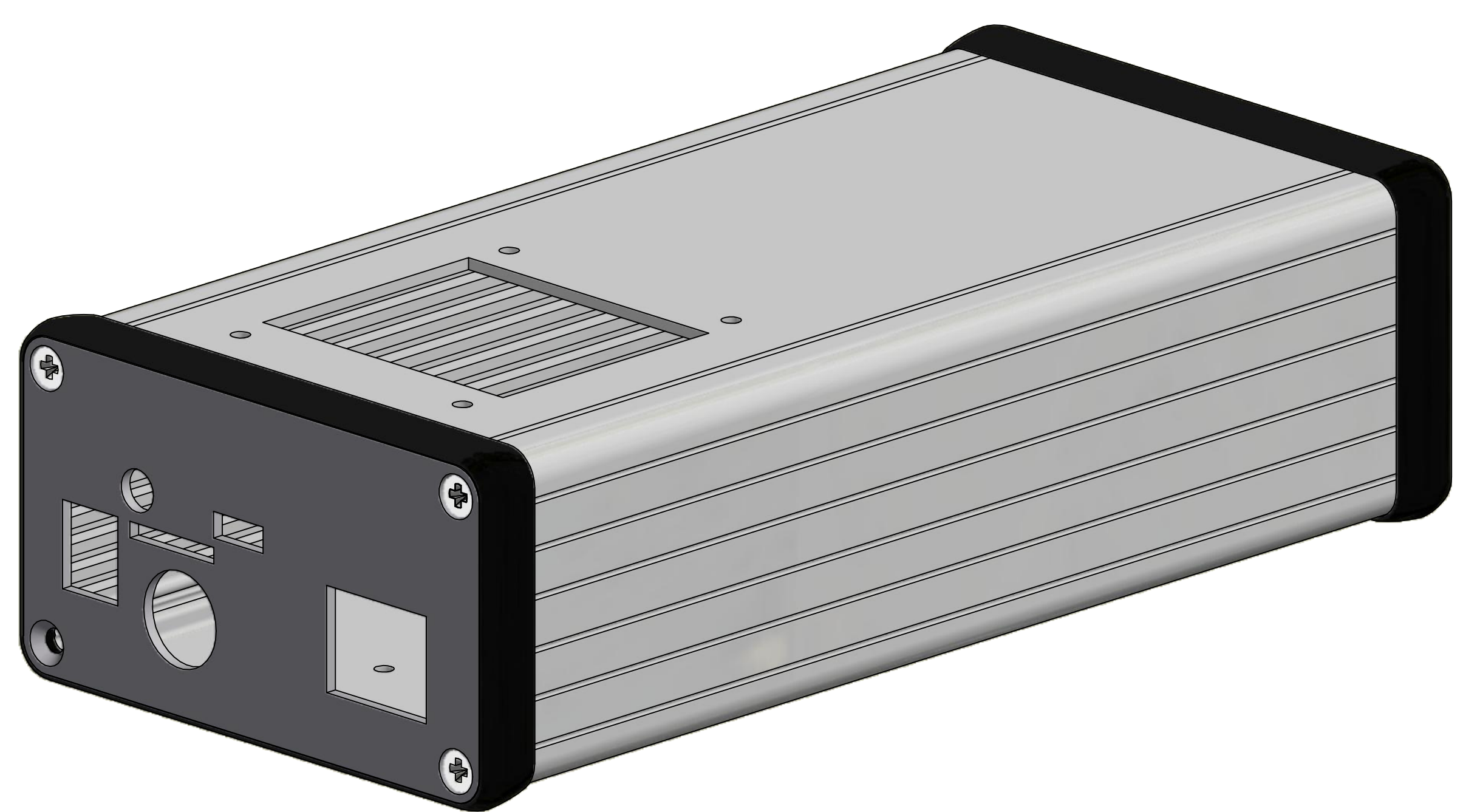

PANEL A

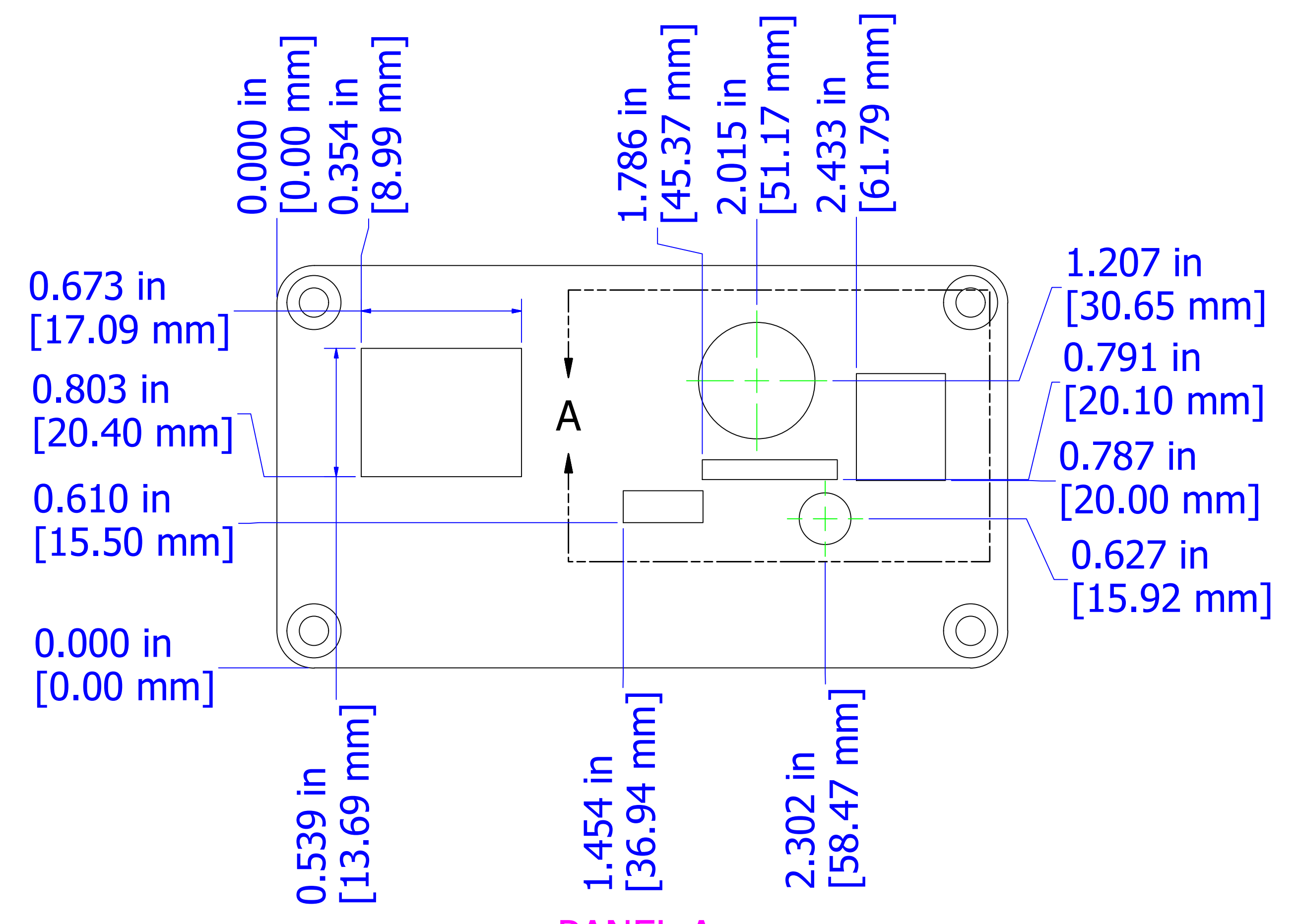

PANEL B

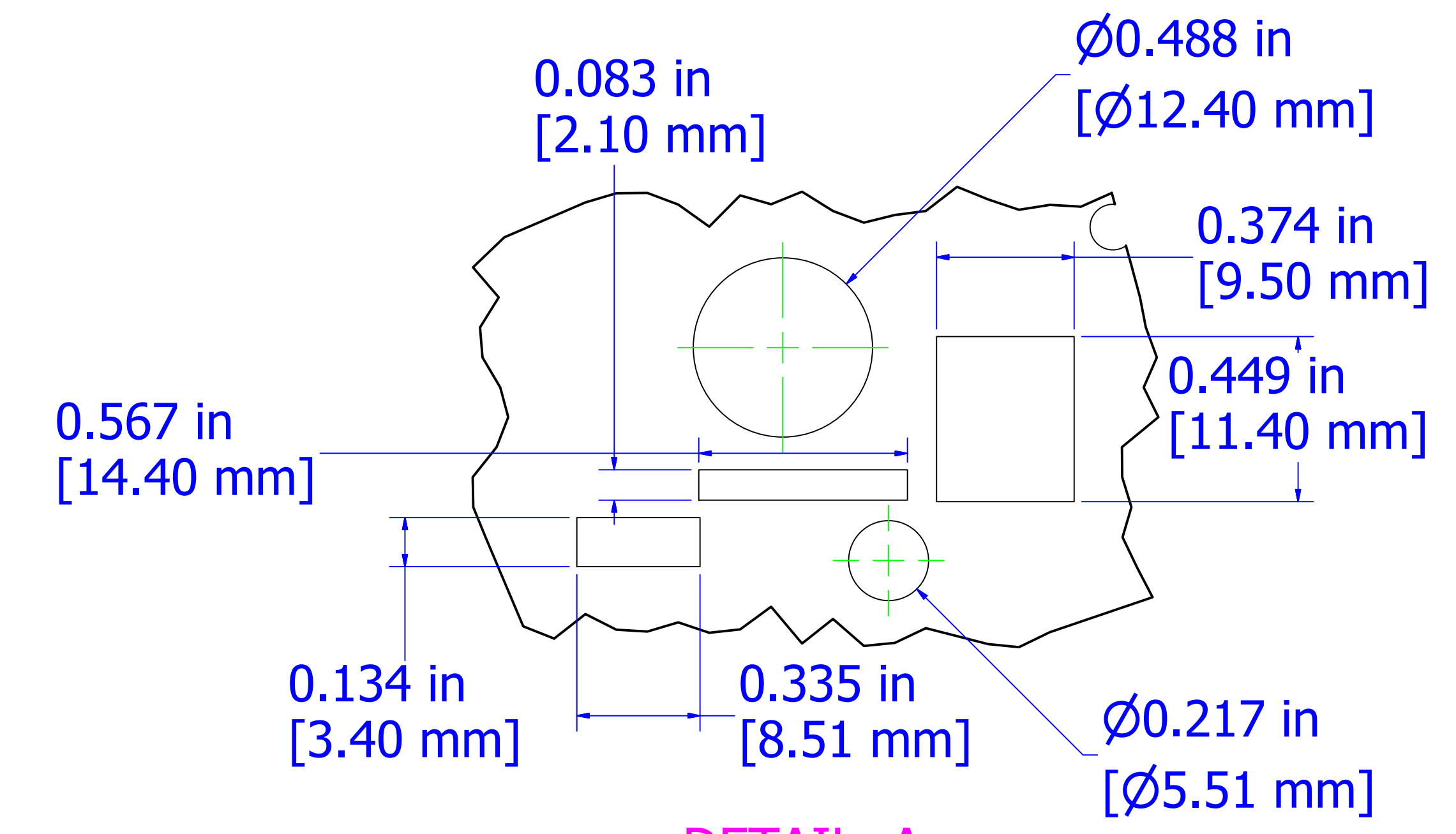

DETAIL A

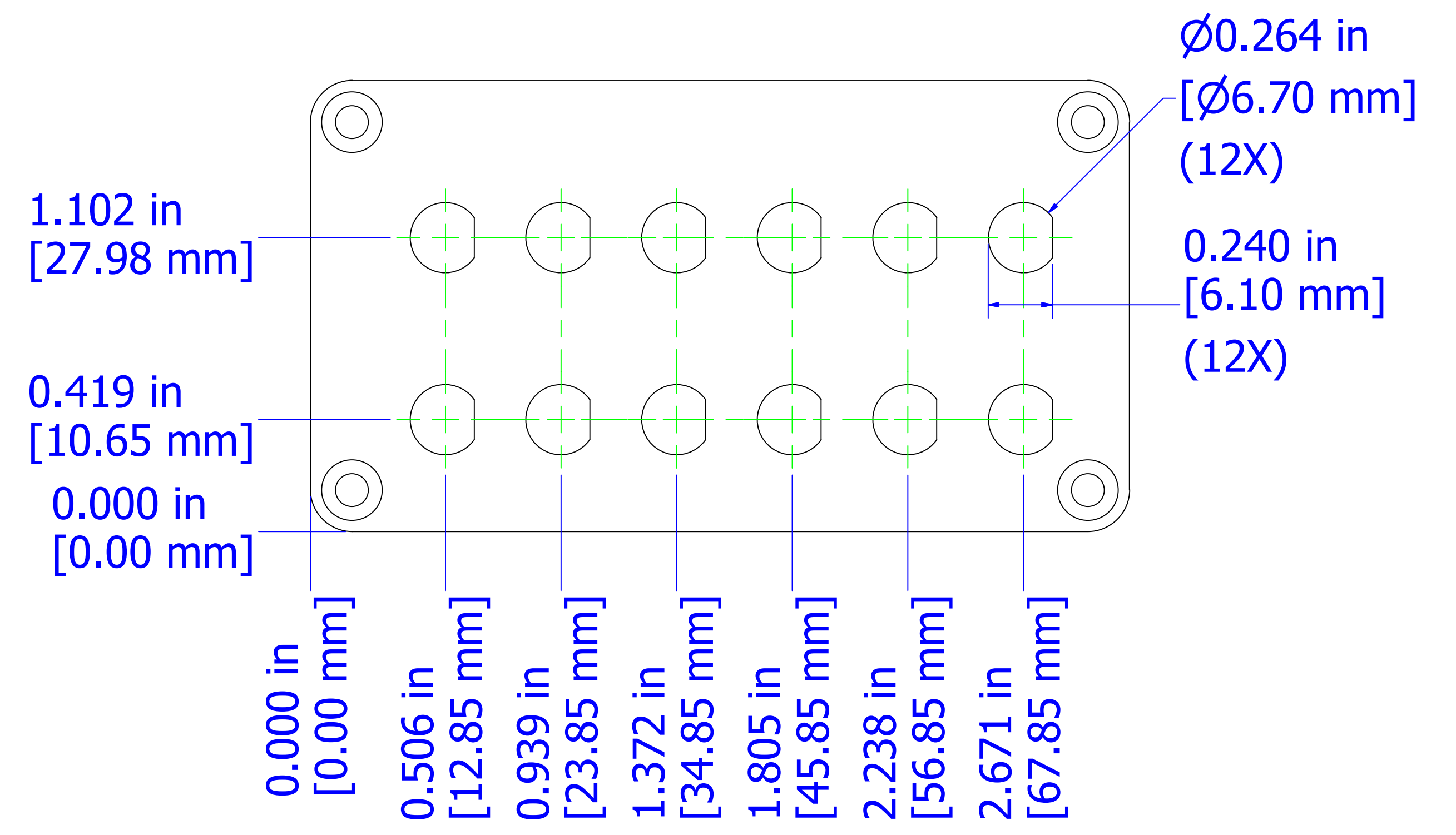

BASIC TOLERANCES:
 MACHINED FEATURES FROM REFERENCE EDGE IS +/- 0.010" OR +/- 0.25MM
 MACHINED FEATURE SIZE IS +/- 0.005" OR +/- 0.13MM
 FEATURE TO FEATURE SPACING +/- 0.005" OR +/- 0.13MM
 MACHINED C'SINK SIZE IS +/- 0.010" OR +/- 0.25MM
 ANY MACHINED POCKET IS +/- 0.015" OR +/- 0.38MM
 ENCLOSURE DIMENSIONS ARE FOR REFERENCE ONLY.

NOTE: CUTOUT CORNER RADIUS 0.031 in TYP. [0.787 mm] UNLESS OTHERWISE SPECIFIED

CUSTOMER: ANALOG DEVICES INC.
QUOTE # MODQU16001770
BASE ENCLOSURE: 1455K1601
MATERIAL SPECIFICATIONS: ALUMINUM
SPECIAL NOTES: N/A

PRINT APPROVAL:
 THIS PRINT WAS APPROVED WITH THE FOLLOWING CONDITIONS:
 () DISAPPROVED - SEE NOTES.
 () APPROVED AS IS.
SIGNED _____
DATE _____

THE INFORMATION CONTAINED IN THIS DRAWING IS THE SOLE PROPERTY OF HAMMOND MFG. ALL SHEETS OF THIS DOCUMENT CONTAIN PROPRIETARY AND CONFIDENTIAL INFORMATION. COPYING, DISCLOSURES TO OTHERS, OR OTHER USE WITHOUT WRITTEN PERMISSION FROM HAMMOND MFG. IS PROHIBITED.

HAMMOND MANUFACTURING®
C09312M REV-C
 www.hammondmfg.com