

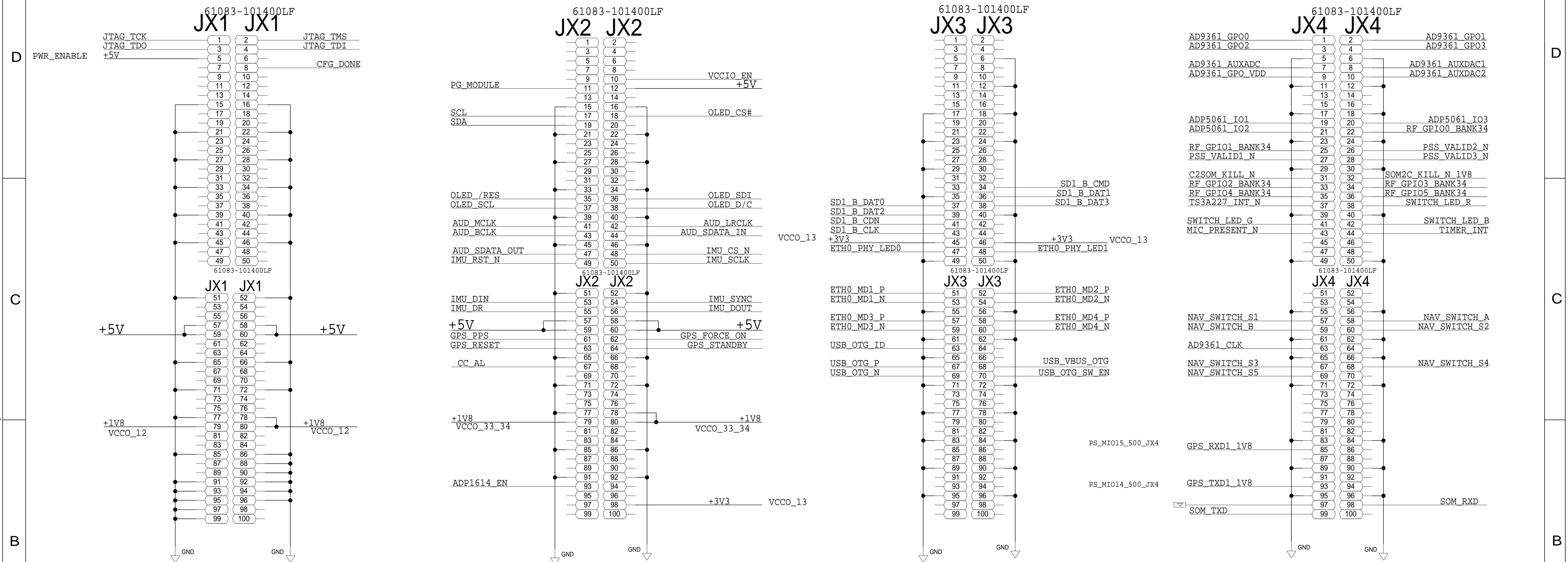

# AD9361+ZYNQ MODULE CONNECTORS

REVISIONS			
REV	DESCRIPTION	DATE	APPROVED



## RF CARD CONNECTOR

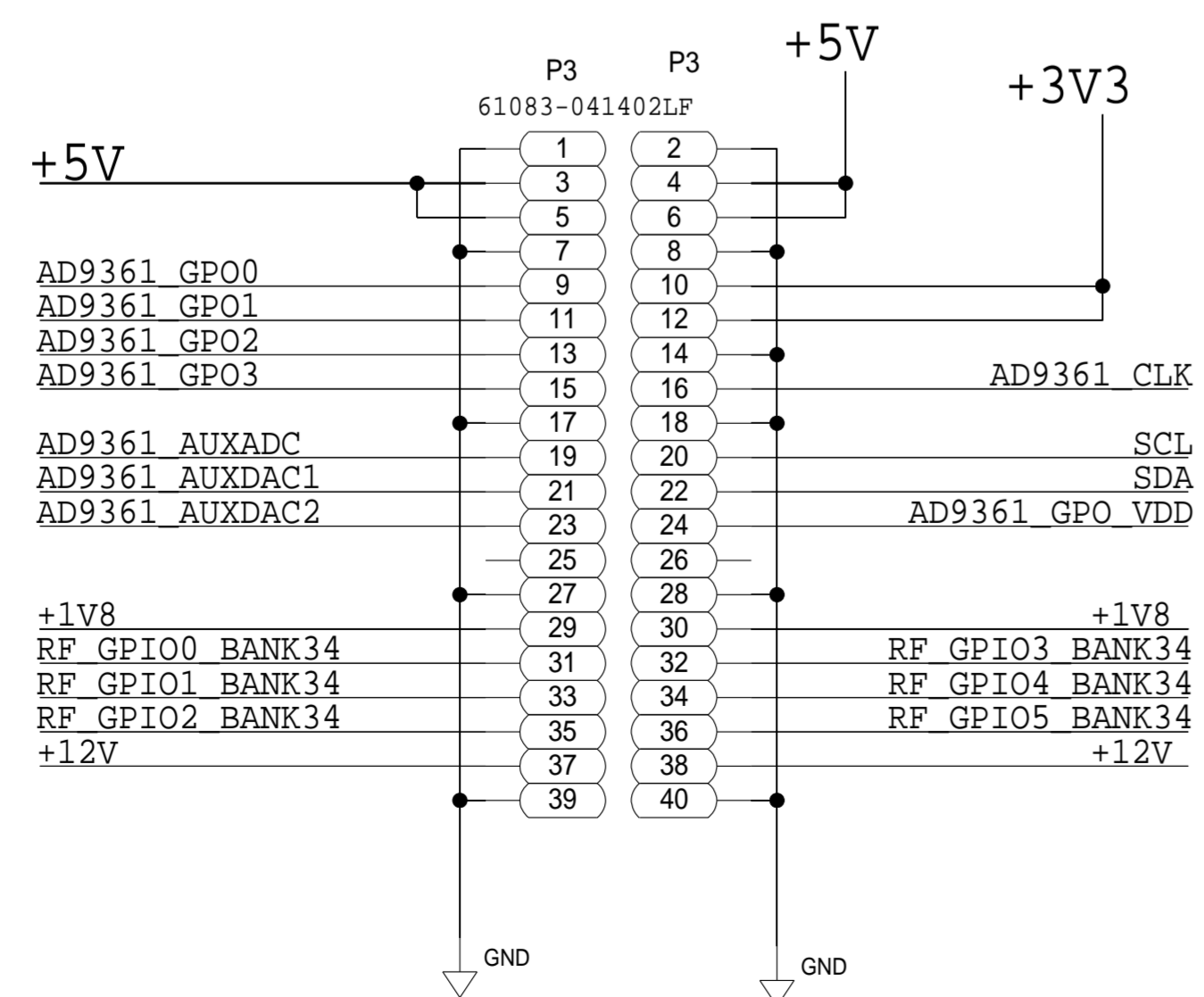

## MATING CONNECTOR

61082-041402LF

## ADDITIONAL CONNECTOR

DEVICE	I2C ADDRESS	PAGE
RF BOARD	0X??	9
AUDIO	0X3A	3
AUDIO SWITCH	0X3B	3
BATTERY CHARGER	0X14	10
ADC	0X2F	4
EEPROM	0X50	4
REAL TIME CLOCK	0X69	5
COULOMB COUNTER	0X64	12

SOM DEVICES	I2C ADDRESS
ADC	0X20
ADM1166	0X68

SCHEMATIC			
HW TYPE : Customer Evaluation Z		Product(s) : N/A	
Product(s) : N/A		Product(s) : N/A	
DESIGN VIEW <DESIGN_VIEW>	DRAWING NO. 02_042967	REV D	
PTD ENGINEER N. WILSON	SIZE D	SCALE 1:1	SHEET 2 OF 13

THIS DRAWING IS THE PROPERTY OF ANALOG DEVICES INC. IT IS NOT TO BE REPRODUCED OR COPIED IN WHOLE OR IN PART, OR USED IN ANY MANNER THAT IS DETRIMENTAL TO THE INTERESTS OF ANALOG DEVICES. THE EQUIPMENT SHOWN HEREON MAY BE PROTECTED BY PATENTS OWNED OR CONTROLLED BY ANALOG DEVICES.

REVISIONS			
REV	DESCRIPTION	DATE	APPROVED

# AUDIO CODEC & AUDIO DETECTION ACCESSORY

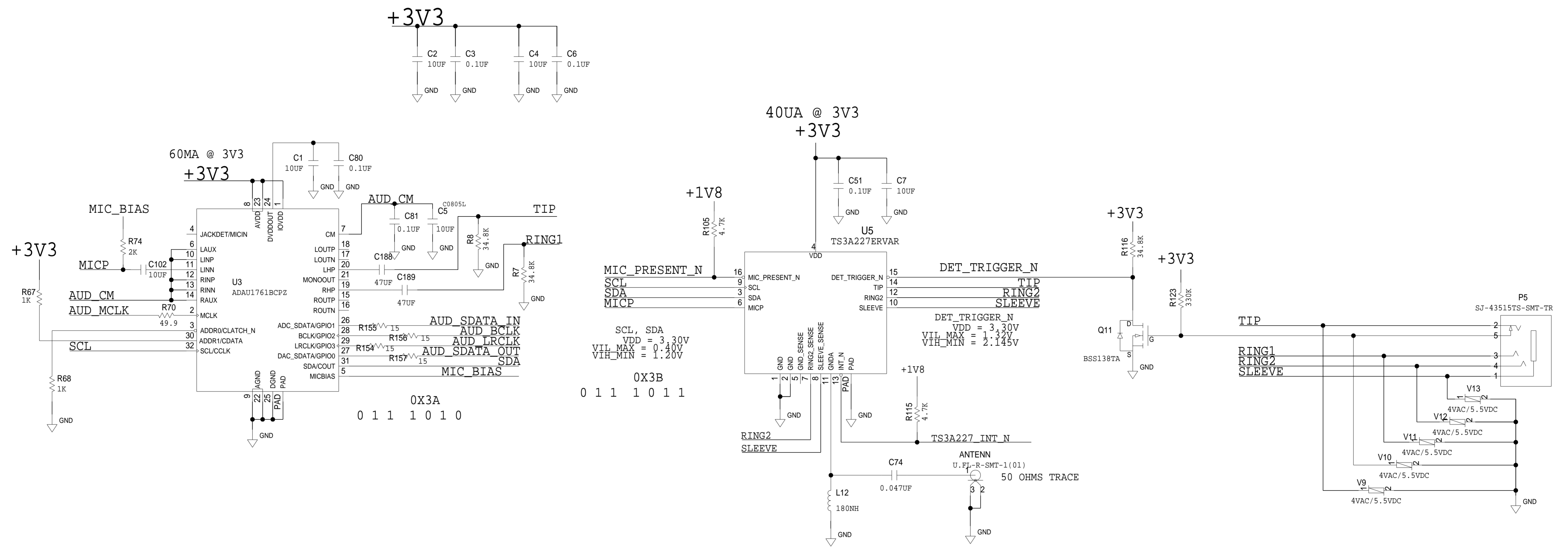

INFORMATION REGARDING TRRS STANDARDS CAN BE FOUND AT:  
[https://en.wikipedia.org/wiki/Phone\\_connector\\_\(audio\)](https://en.wikipedia.org/wiki/Phone_connector_(audio))

ANALOG DEVICES		SCHEMATIC		
HW TYPE : Customer Evaluation Z Product(s) : N/A		DRAWING NO. 02_042967		
DESIGN VIEW <DESIGN_VIEW>		REV D	SHEET 3 OF 13	
PTD ENGINEER N. WILSON		SIZE D	SCALE 1:1	

REVISIONS			
REV	DESCRIPTION	DATE	APPROVED

### USB OTG

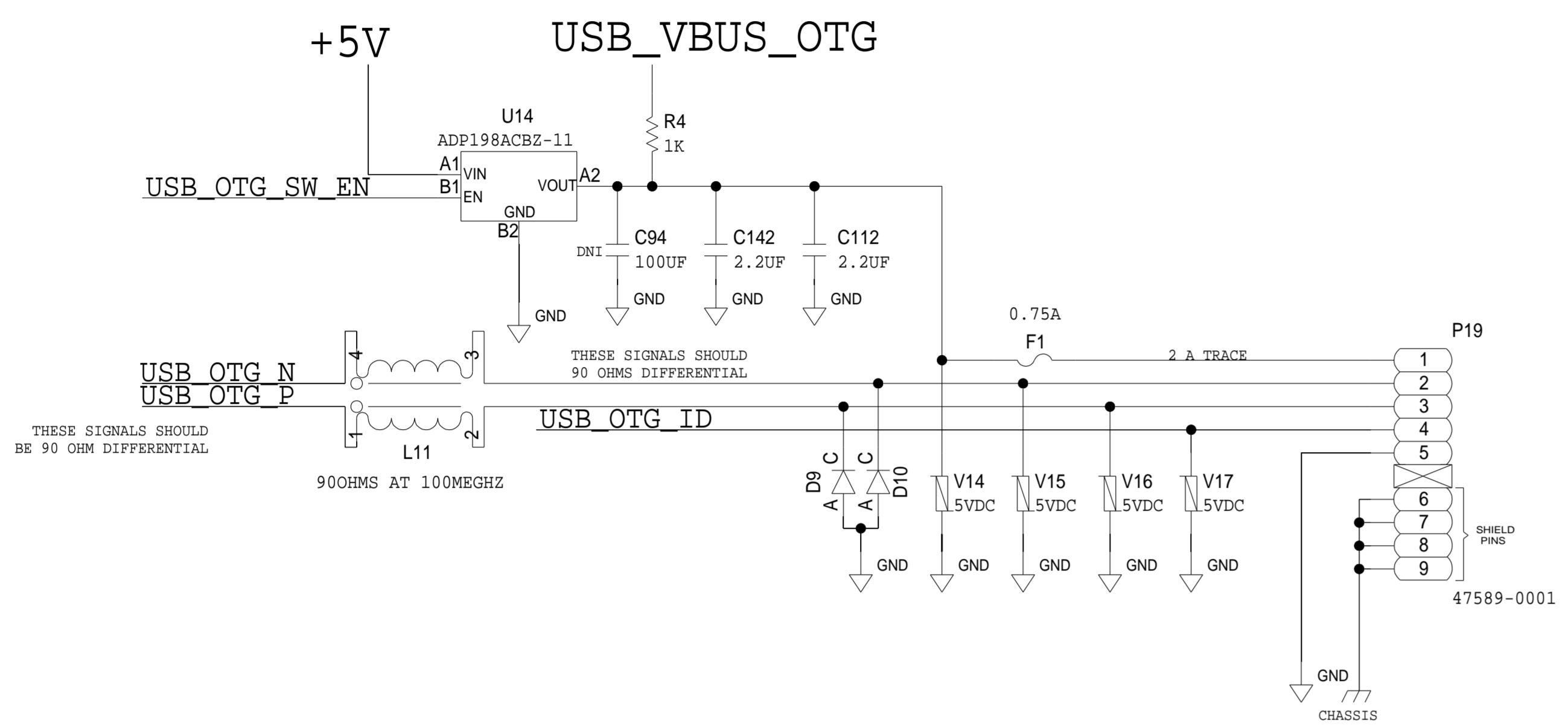

### EEPROM

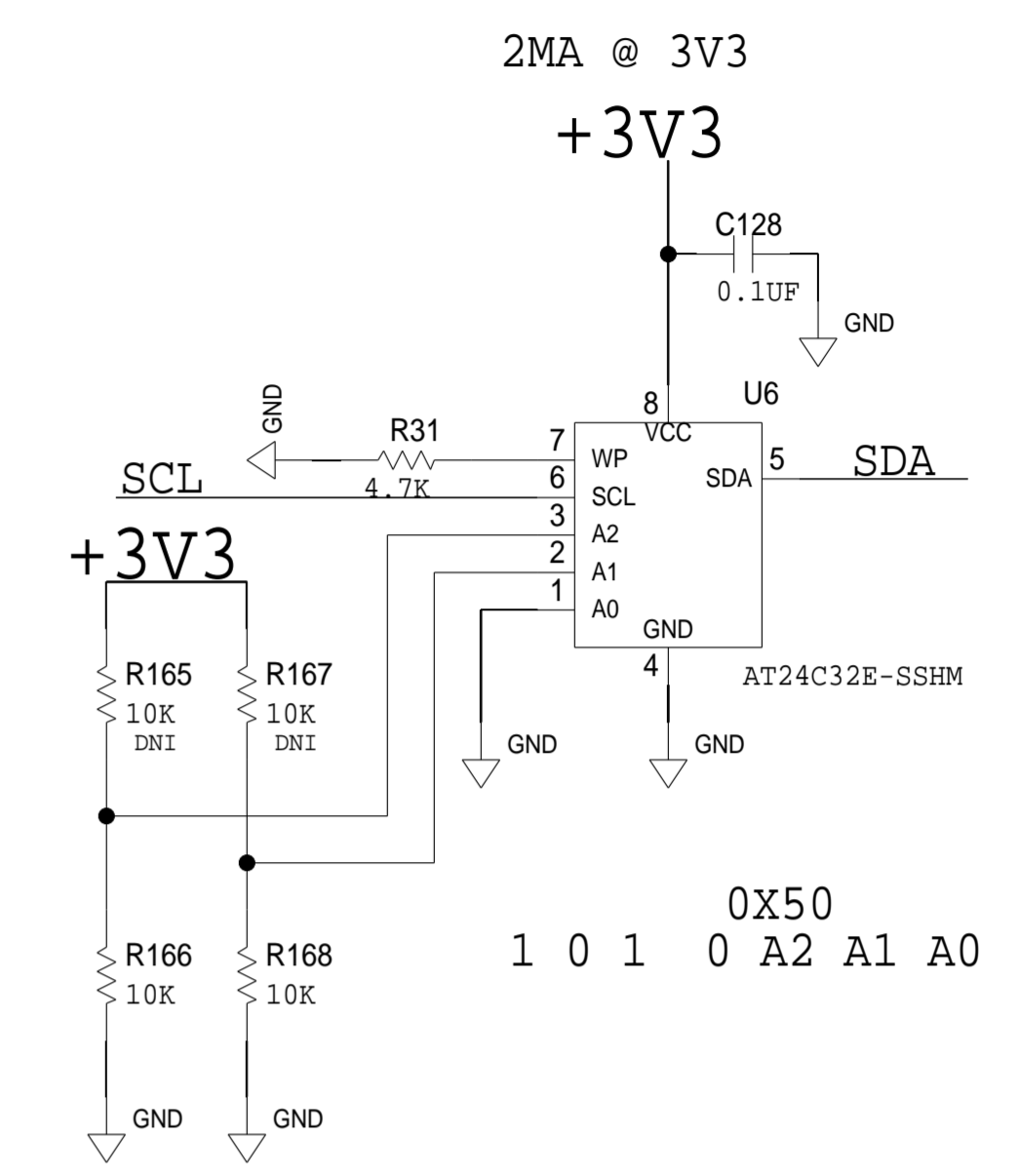

### MICRO SD CARD

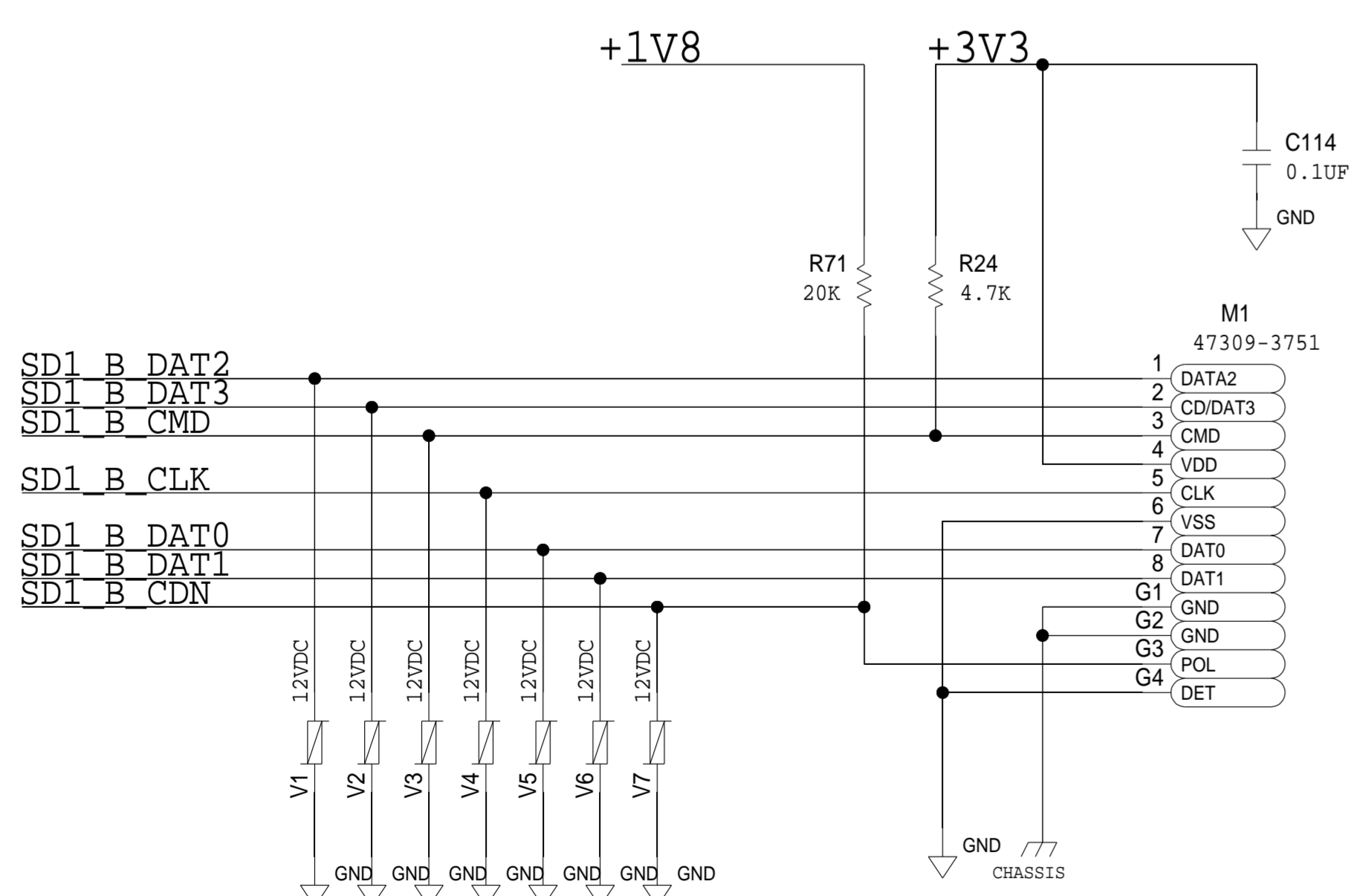

### VOLTAGE MONITORING

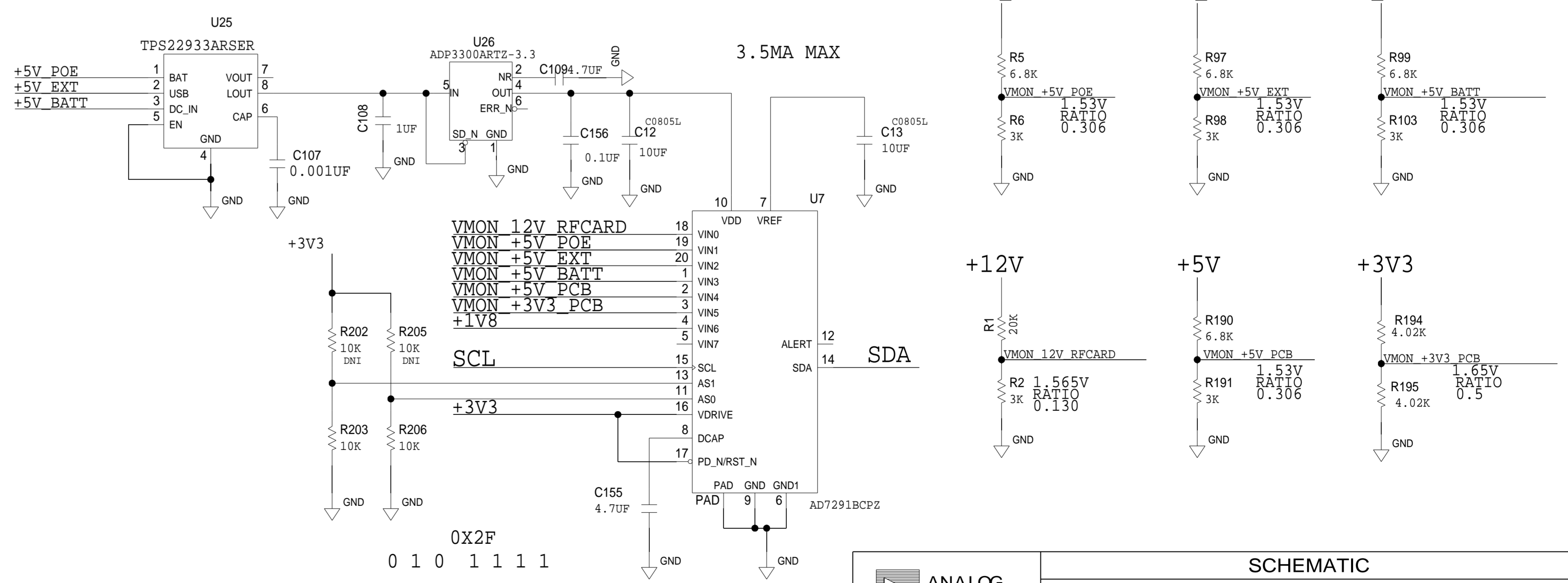

### PUSH PUSH

	<b>SCHEMATIC</b>		
	HW TYPE : Customer Evaluation Z		
	Product(s) : N/A		
	: N/A		
DESIGN VIEW	DRAWING NO.		REV
<DESIGN_VIEW>	02_042967		D
PTD ENGINEER	SIZE	SCALE	SHEET 4 OF 13
N. WILSON	D	1:1	

REVISIONS			
REV	DESCRIPTION	DATE	APPROVED

# GPS

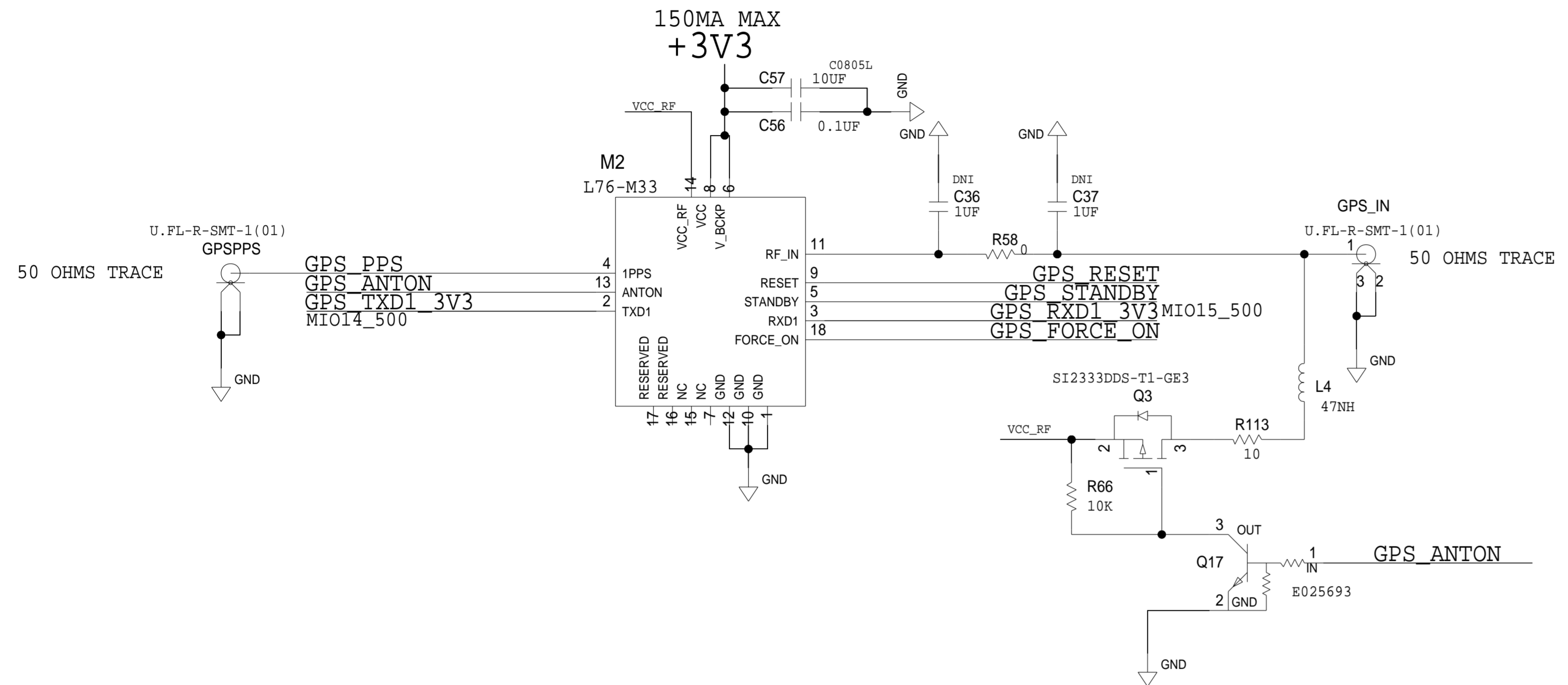

# LEVEL TRANSLATOR

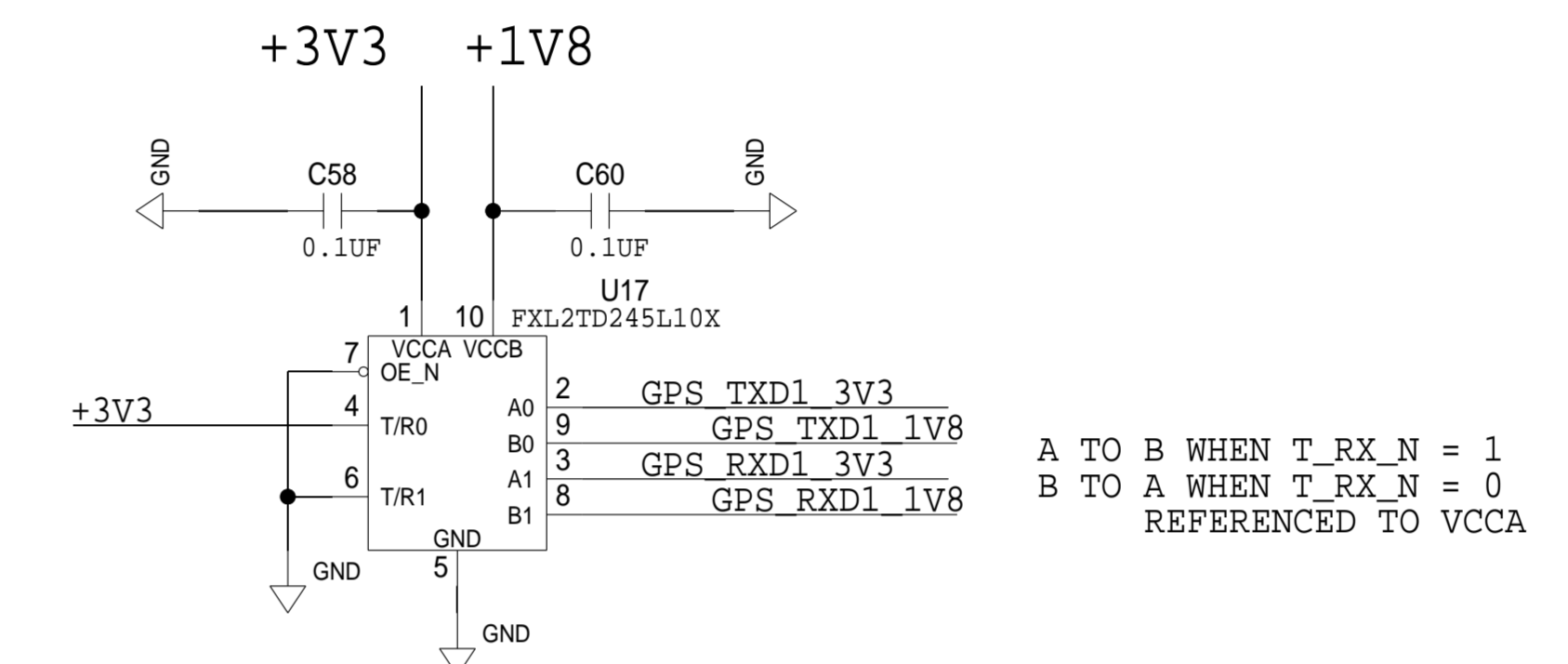

# JTAG

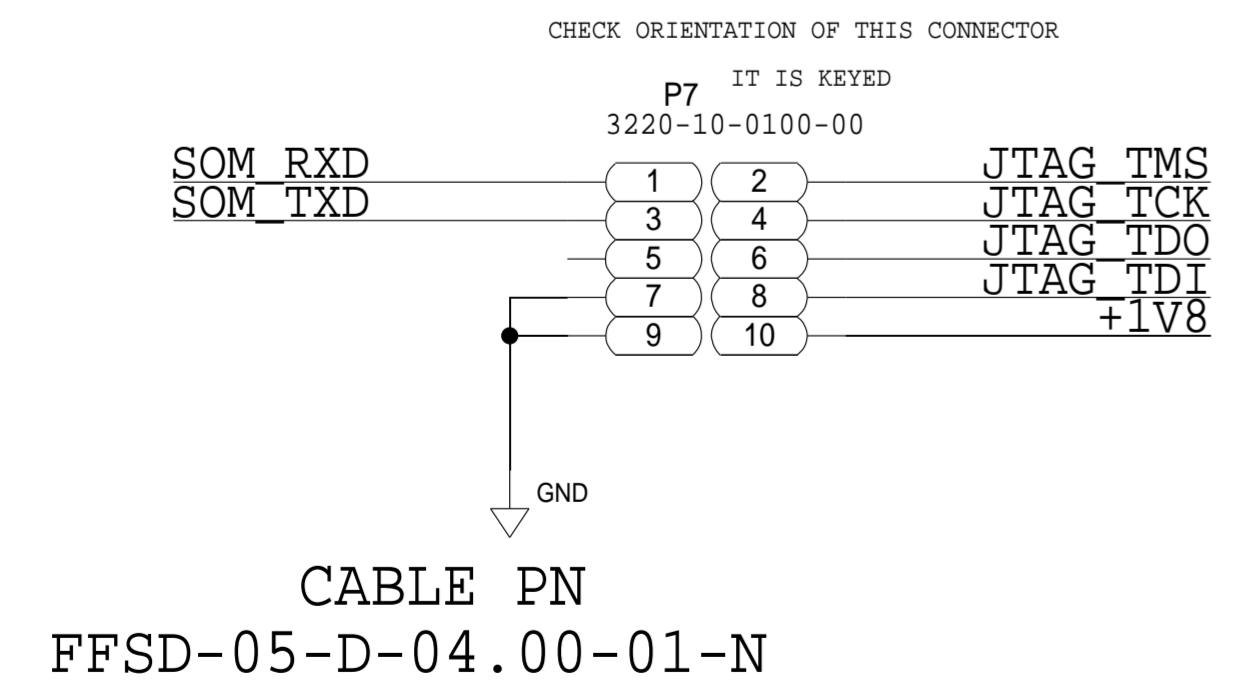

# FAN

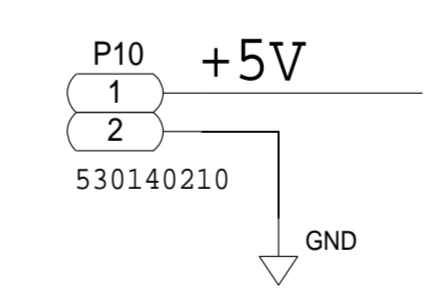

SUNON PN  
MC25060V1-000U-A99

FAN CONNECTOR PN  
0510040200

CRIMP HOUSING  
50011-8000

PCB CONNECTOR PN  
0530140210

SCHEMATIC			
HW TYPE : Customer Evaluation Z		Product(s) : N/A	
DESIGN VIEW : <DESIGN_VIEW>		DRAWING NO. : 02_042967	REV : D
PTD ENGINEER : N. WILSON	SIZE : D	SCALE : 1:1	SHEET 5 OF 13

REVISIONS			
REV	DESCRIPTION	DATE	APPROVED

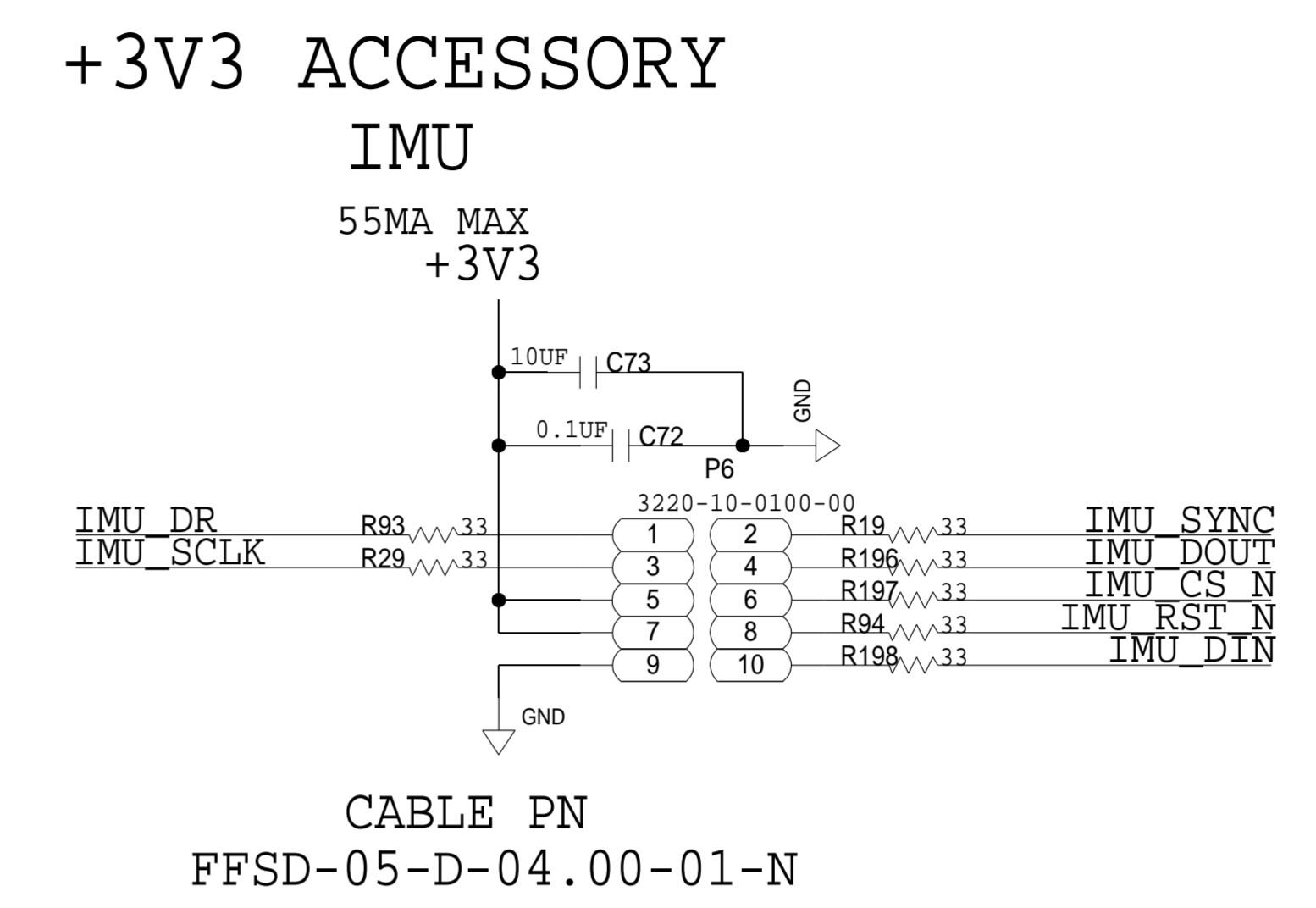
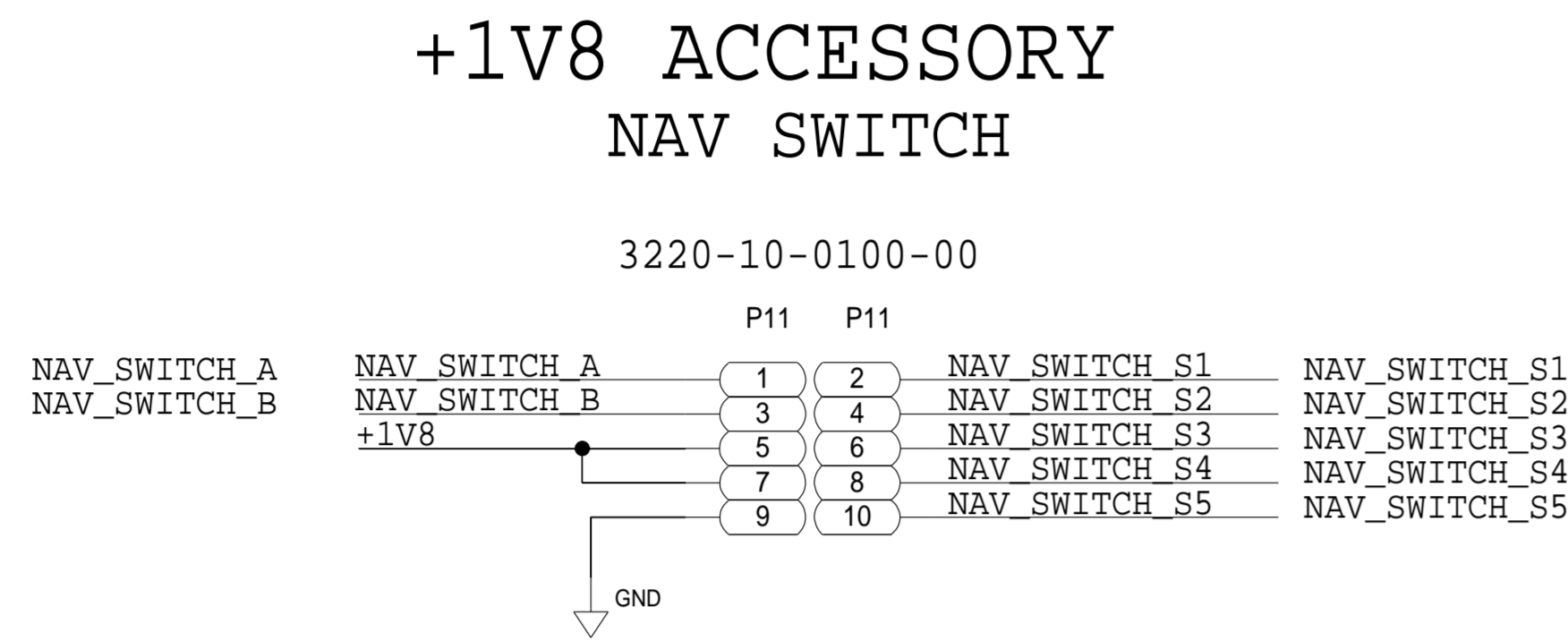

## I2C ADDRESS TRANSLATOR

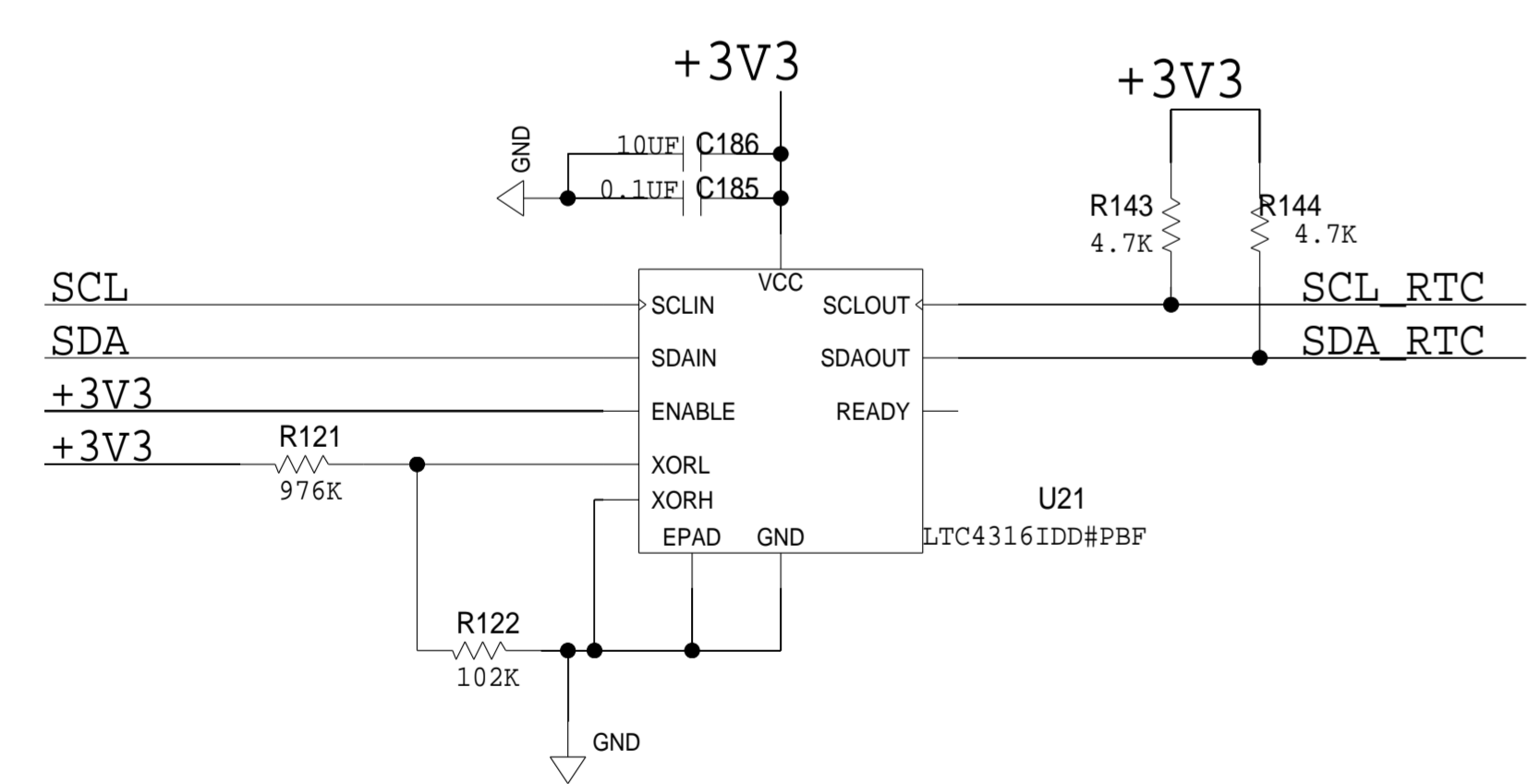

OUTPUT ADDRESS = 0X68 = 110 1000  
 TRANSLATION BYE = 000 0001  
 INPUT ADDRESS = 0X69 = 110 1001

## REAL TIME CLOCK

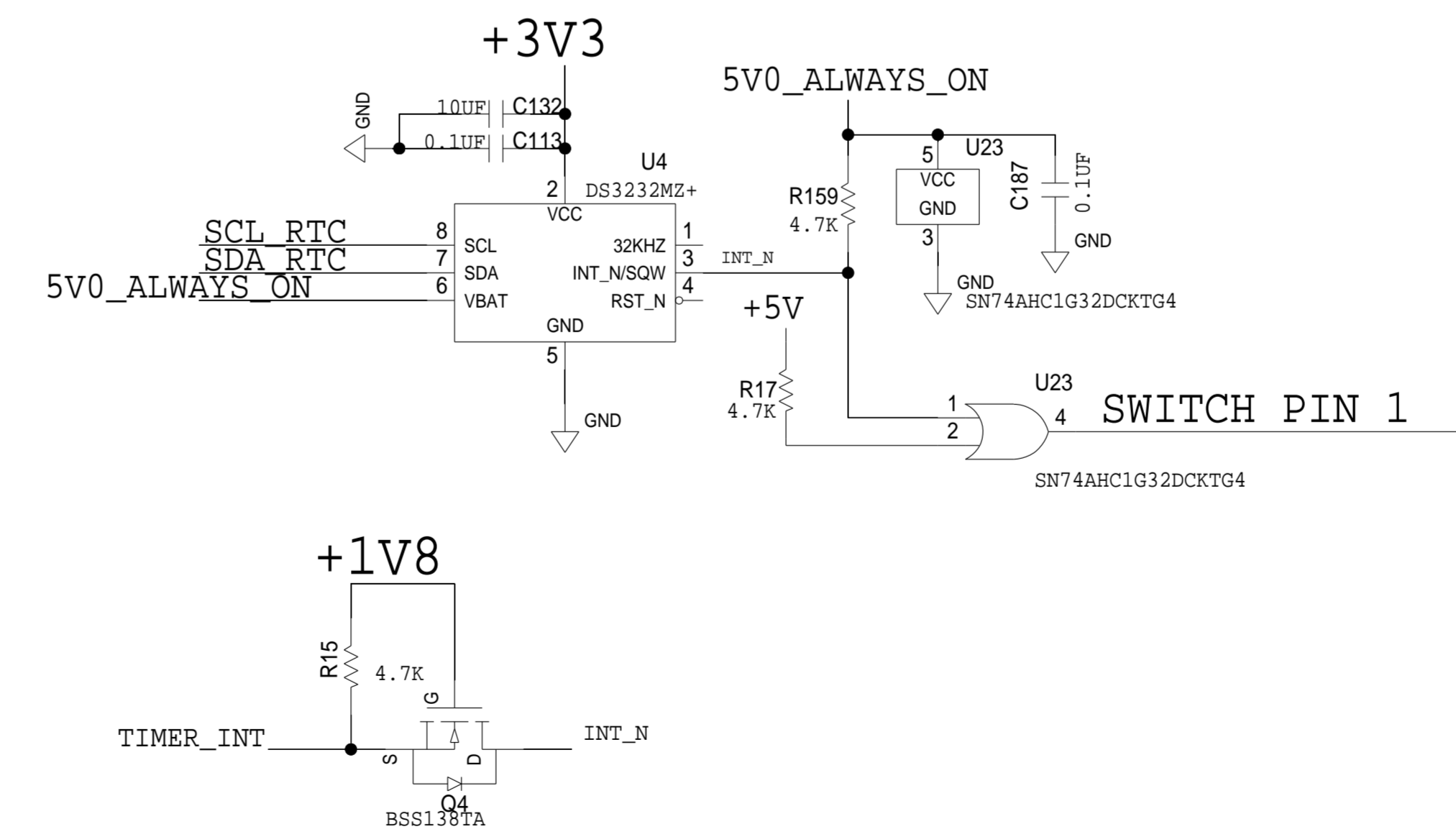

## OLED

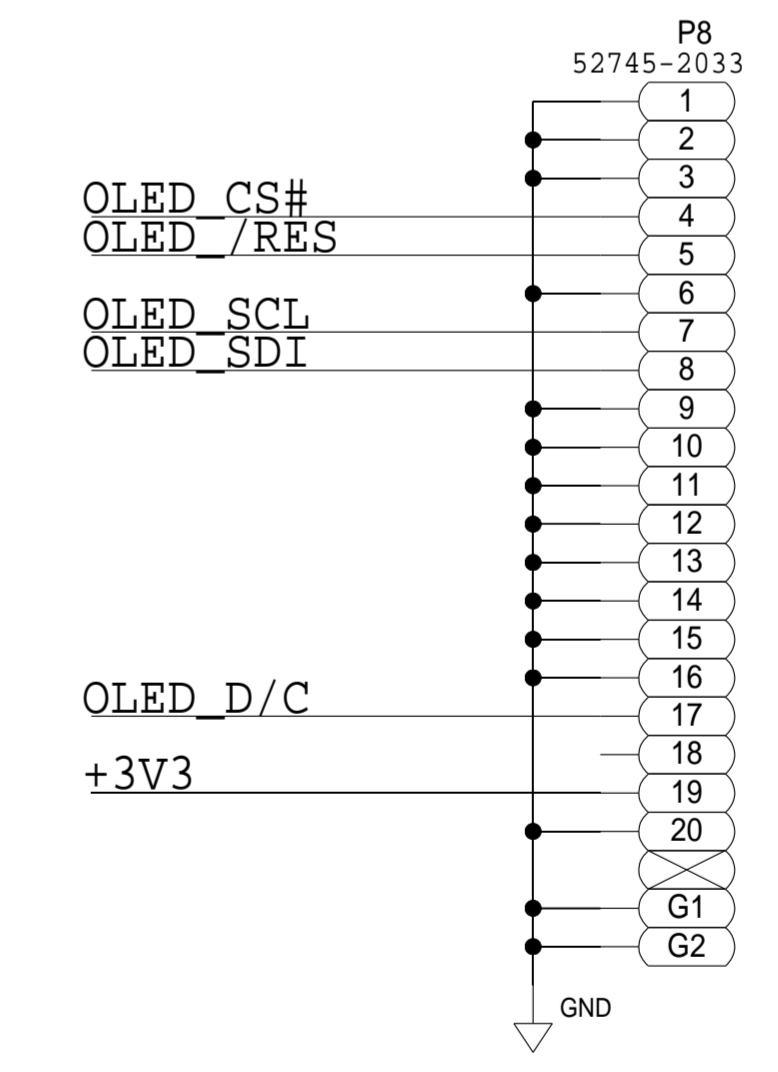

CONNECTOR PN : 52745-2033  
 CABLE PN : 0150200207 : 50.80 MM  
 CABLE PN : 0152660209 : 76.20 MM  
 CABLE PN : 0152660211 : 101.6 MM

ANALOG DEVICES		SCHEMATIC		
<small>THIS DRAWING IS THE PROPERTY OF ANALOG DEVICES INC. IT IS NOT TO BE REPRODUCED OR COPIED IN WHOLE OR IN PART, OR USED IN FURNISHING INFORMATION TO OTHERS, OR FOR ANY OTHER PURPOSE DETRIMENTAL TO THE INTERESTS OF ANALOG DEVICES. THE EQUIPMENT SHOWN HEREON MAY BE PROTECTED BY PATENTS OWNED OR CONTROLLED BY ANALOG DEVICES.</small>		HW TYPE : Customer Evaluation Z		REV
		Product(s) : N/A		D
DESIGN VIEW <DESIGN_VIEW>		DRAWING NO. 02_042967	SHEET 6 OF 13	
PTD ENGINEER N. WILSON		SIZE D	SCALE 1:1	



# GENERATING 5V FROM EXTERNAL SOURCE

REVISIONS			
REV	DESCRIPTION	DATE	APPROVED

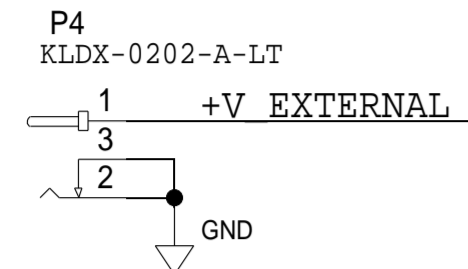

DC BARREL JACK  
2.0MM ID  
5.5MM OD

NEED TO CHECK IF THIS IS 2.1MM JACK

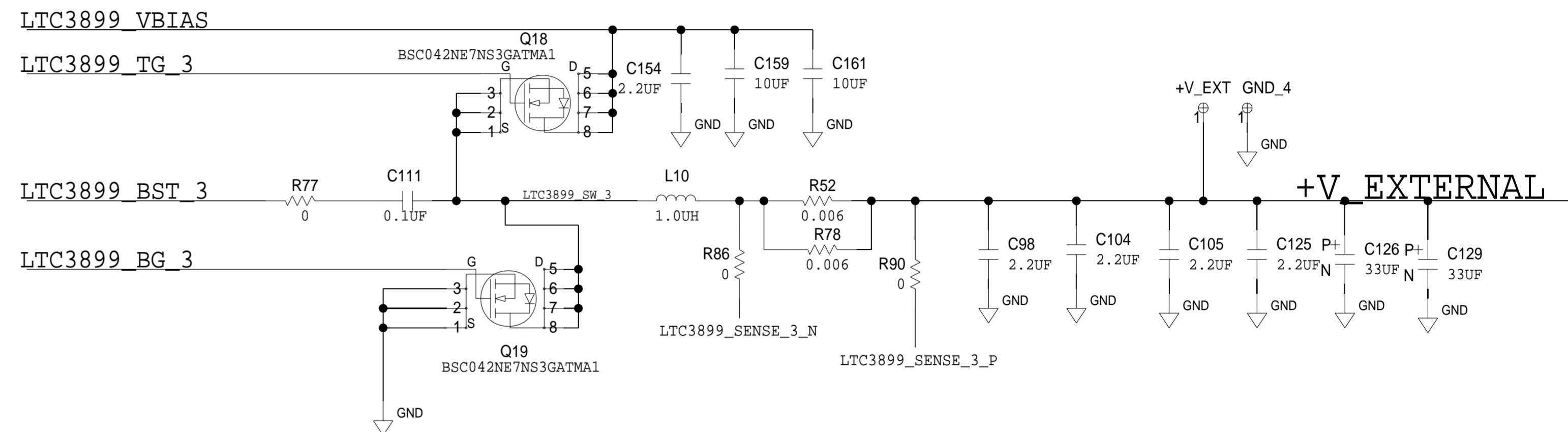
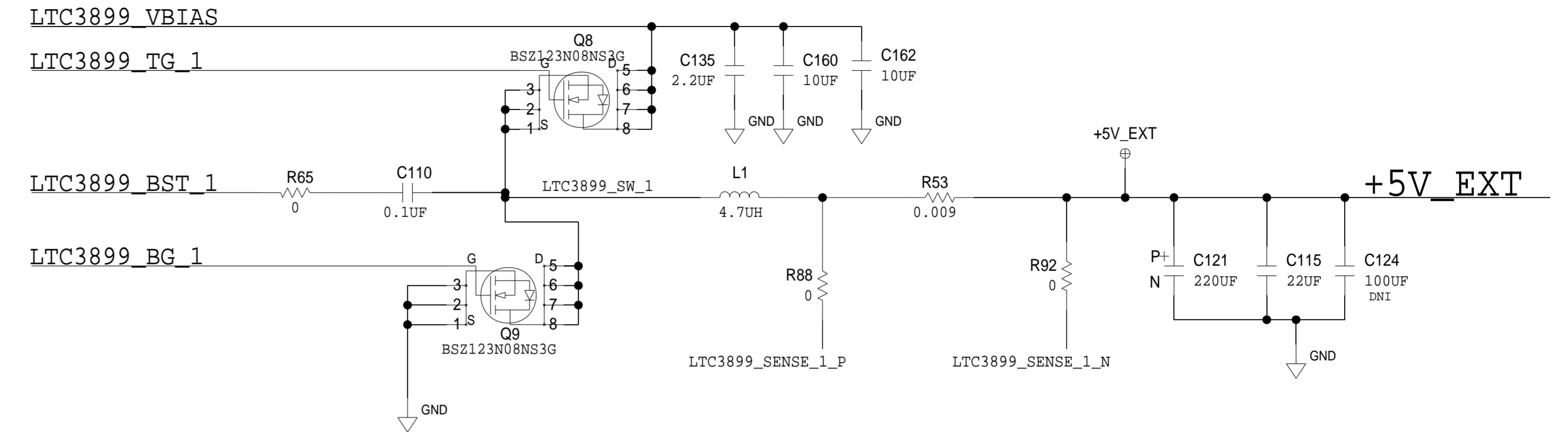
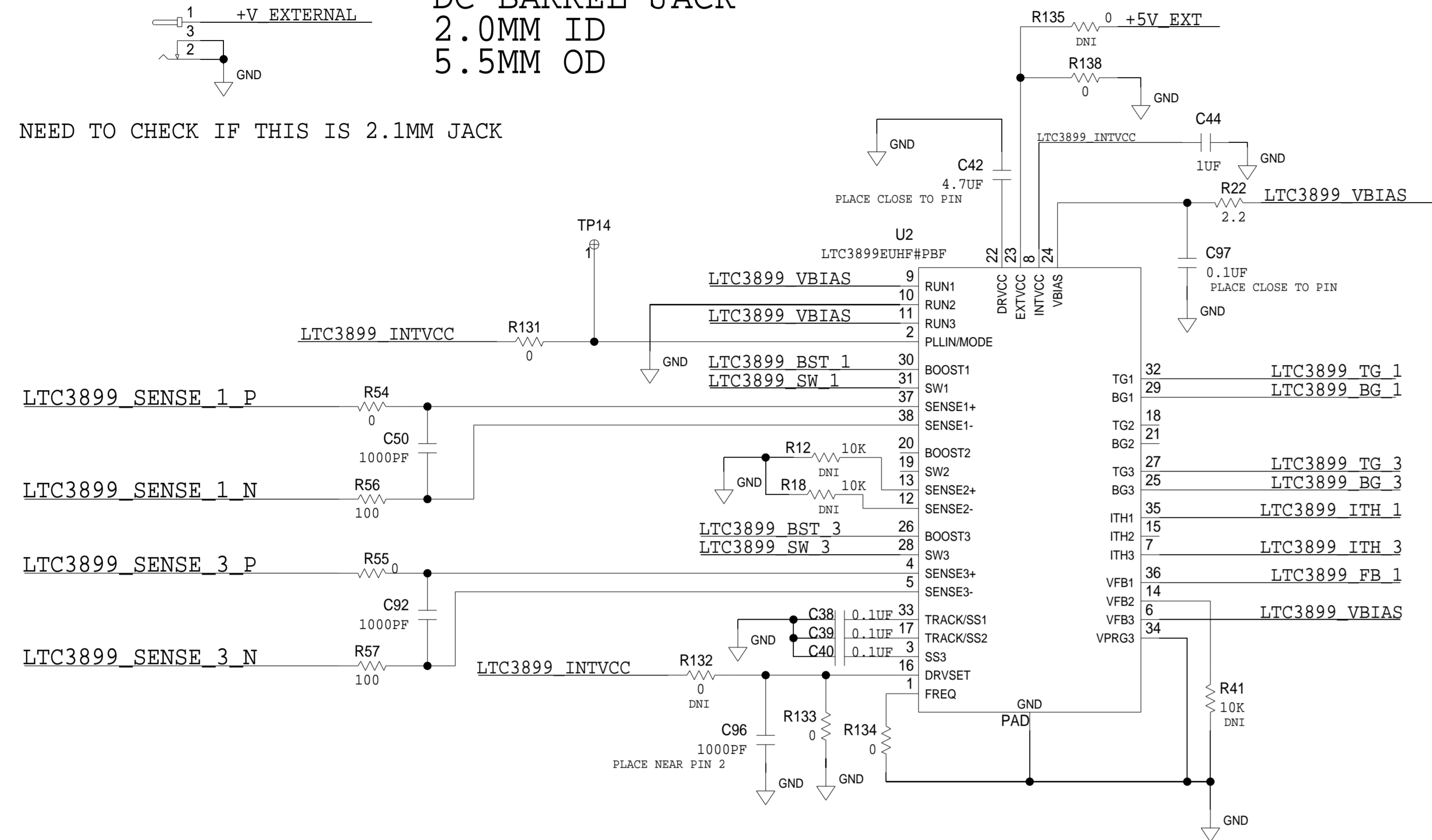

# GENERATING 12V FOR RF CARD

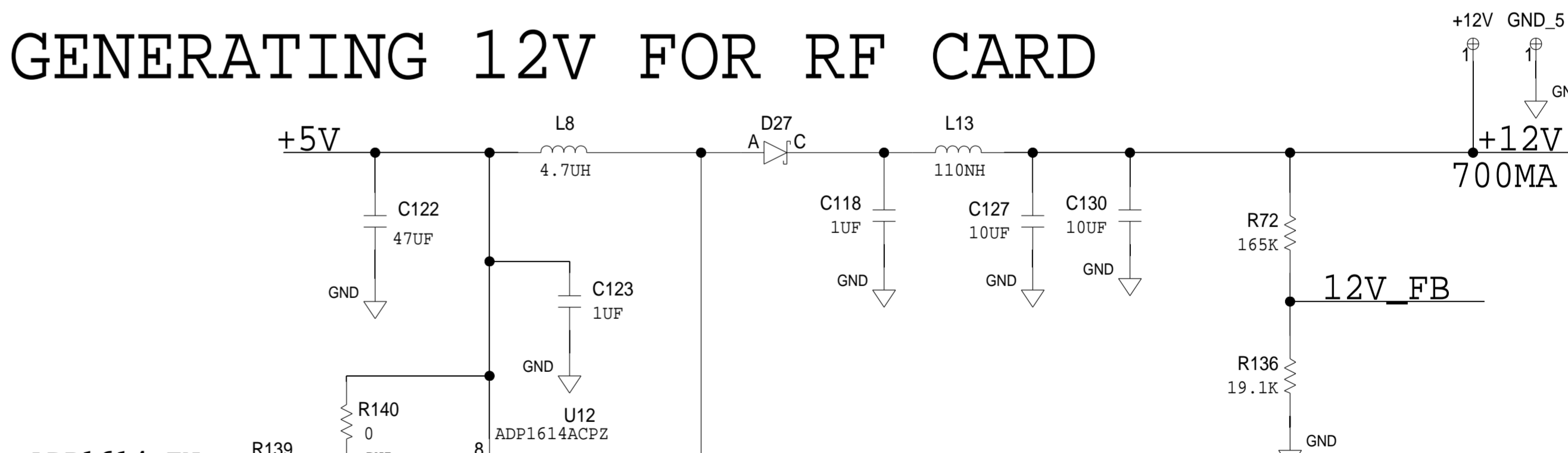
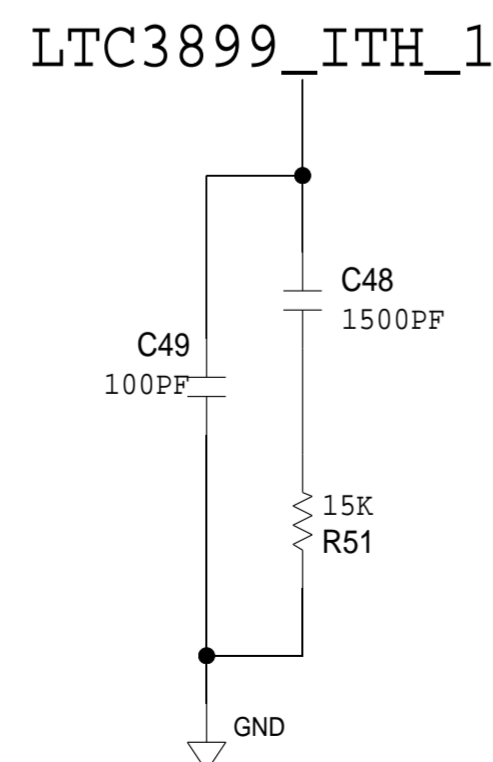
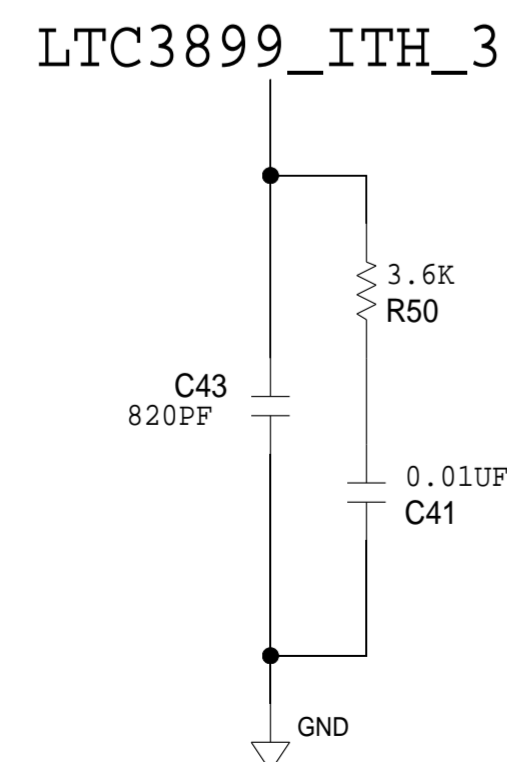
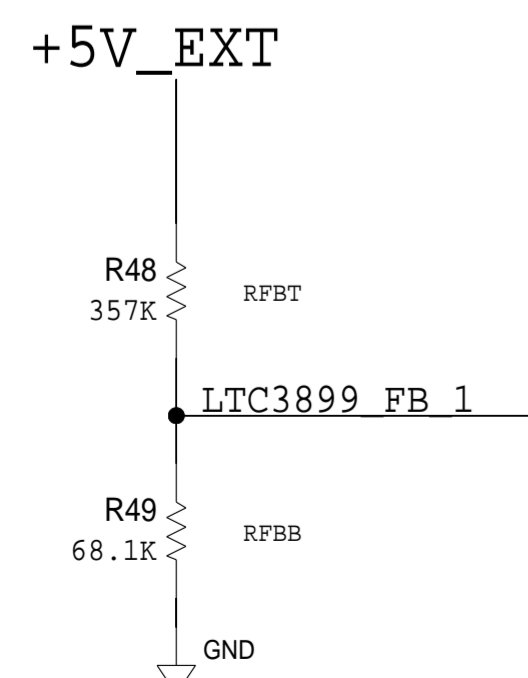

$$TSS = \frac{10NF * 1.23V}{5.5UA} = 2.2MS$$

$$FSW = 650KHZ$$

SCHEMATIC			
ANALOG DEVICES		HW TYPE : Customer Evaluation Z	
Product(s) : N/A		Product(s) : N/A	
DESIGN VIEW <DESIGN_VIEW>	DRAWING NO. 02_042967	REV D	REV D
PTD ENGINEER N. WILSON	SIZE D	SCALE 1:1	SHEET 8 OF 13



# GENERATING 5V FROM V\_BATT

REVISIONS			
REV	DESCRIPTION	DATE	APPROVED

## I2C LVL TRANSLATOR

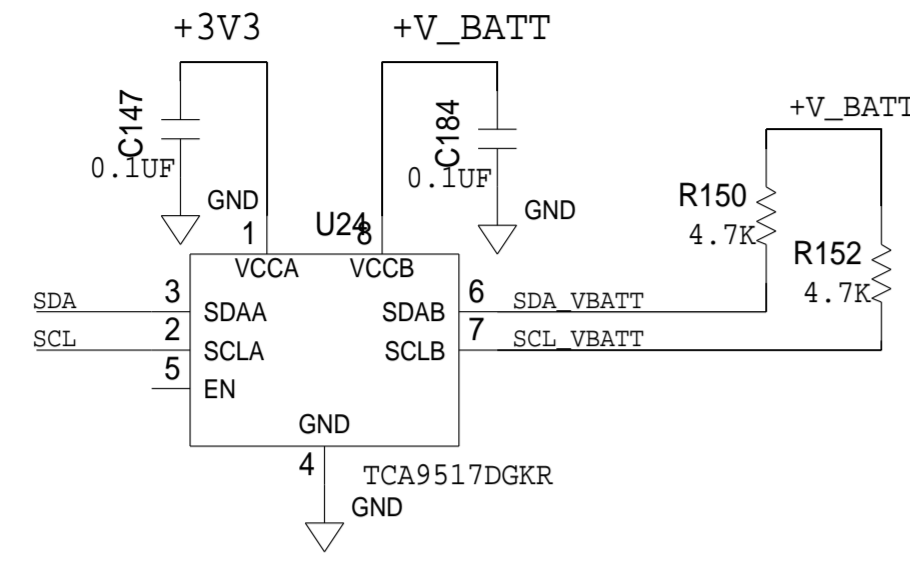

## I2C LVL TRANSLATOR

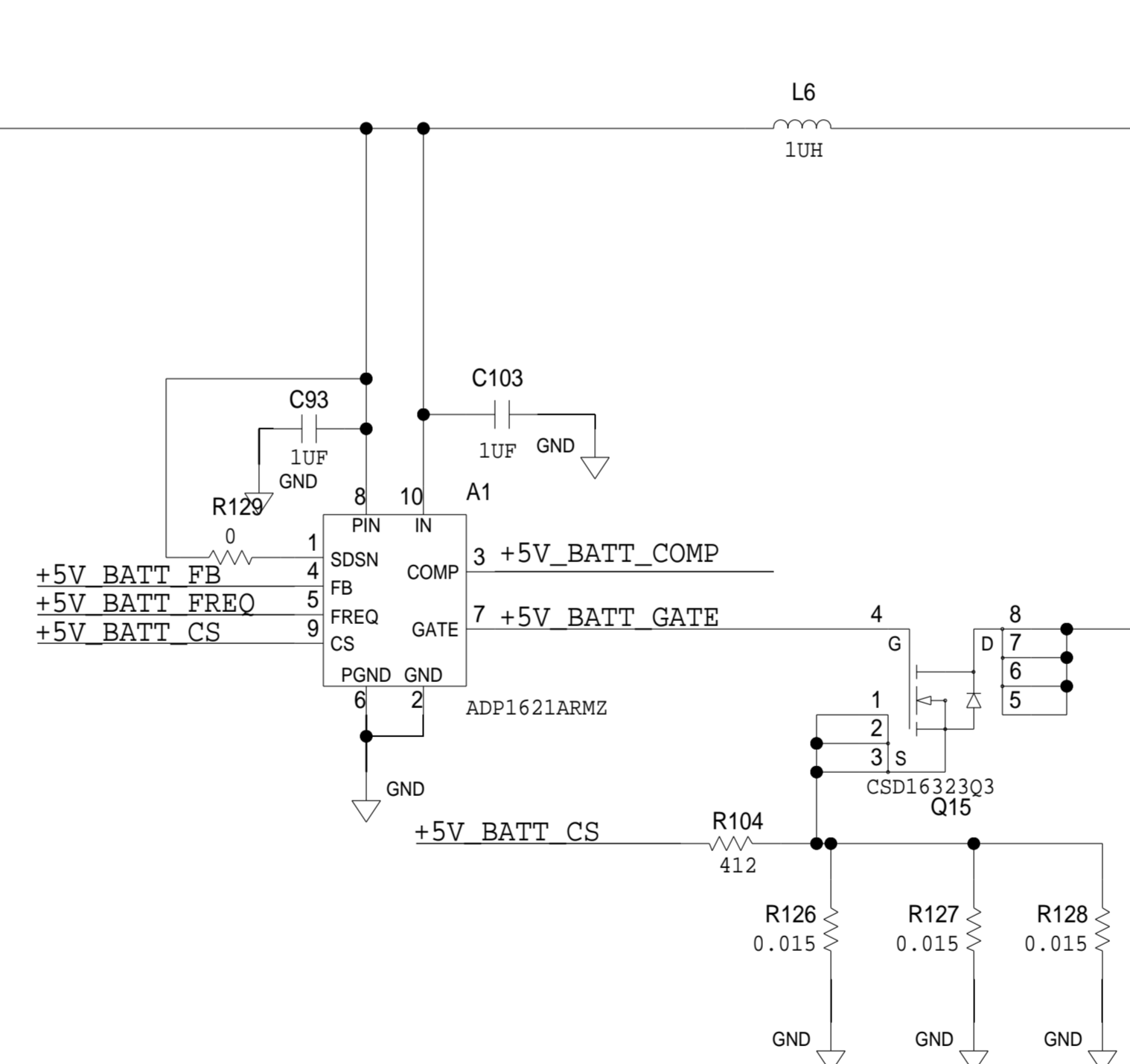
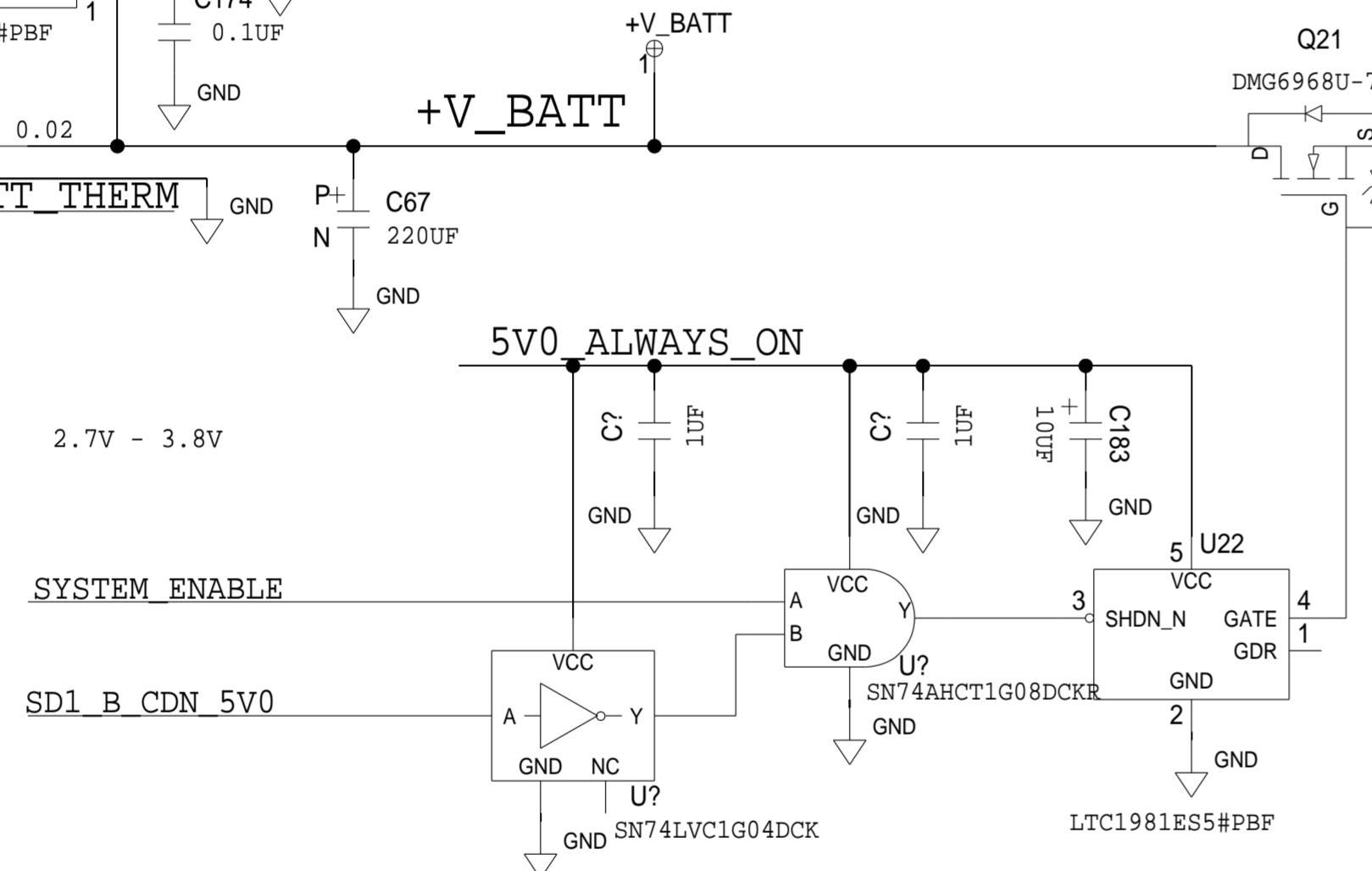
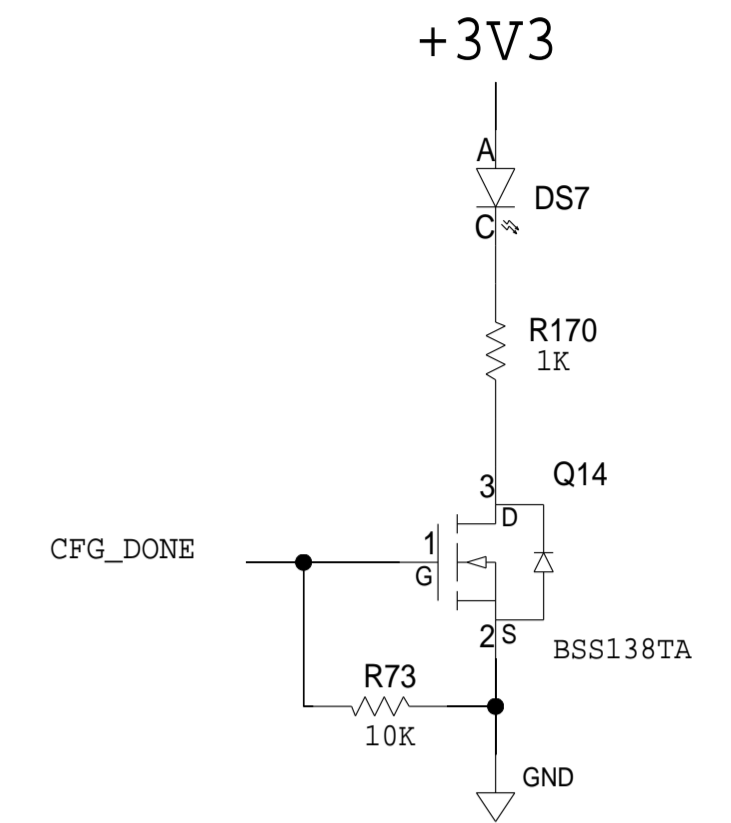
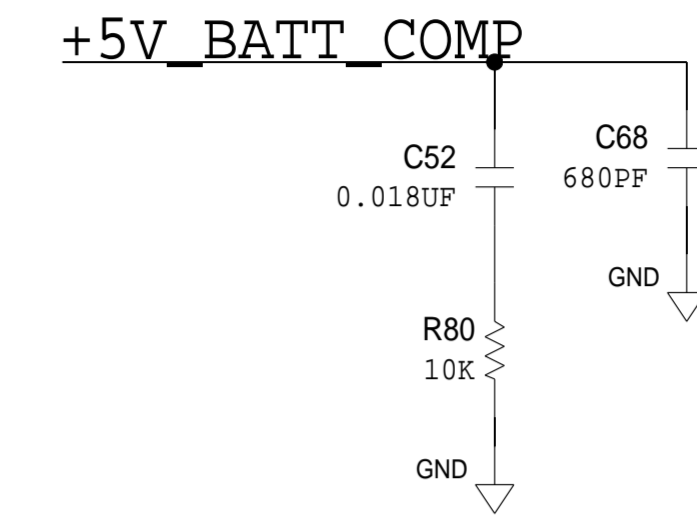
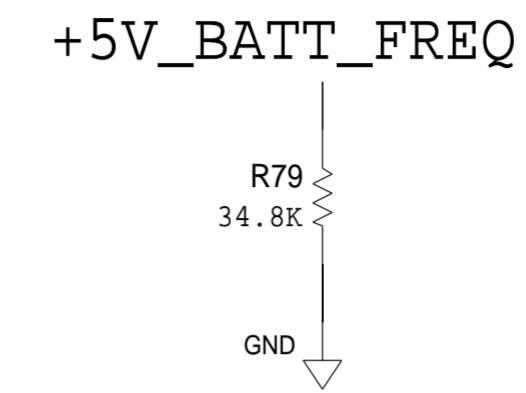
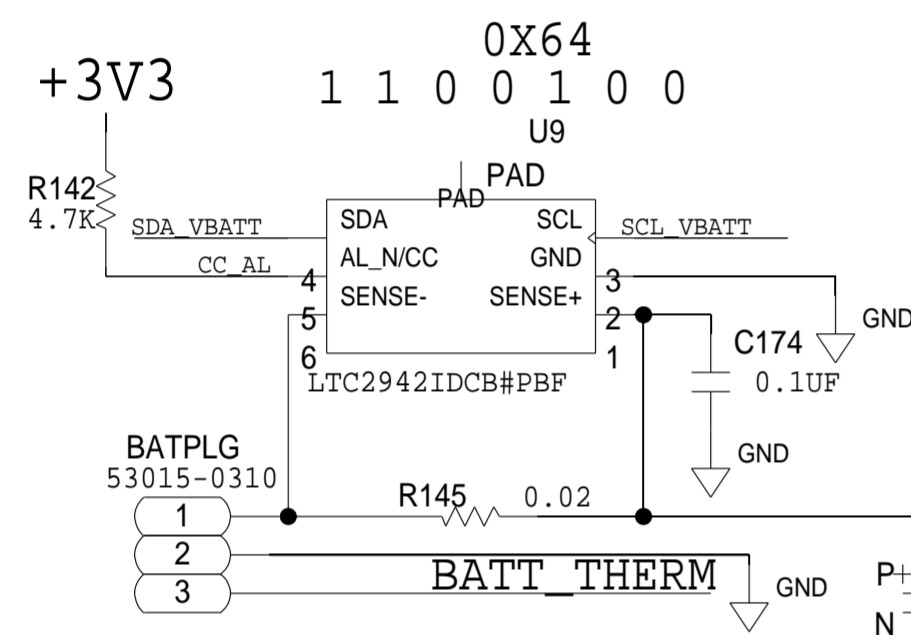

$$TSS = \frac{2048}{0.6\text{MHZ}} = 3.4\text{MS}$$

$$FSW = 600\text{KHZ}$$

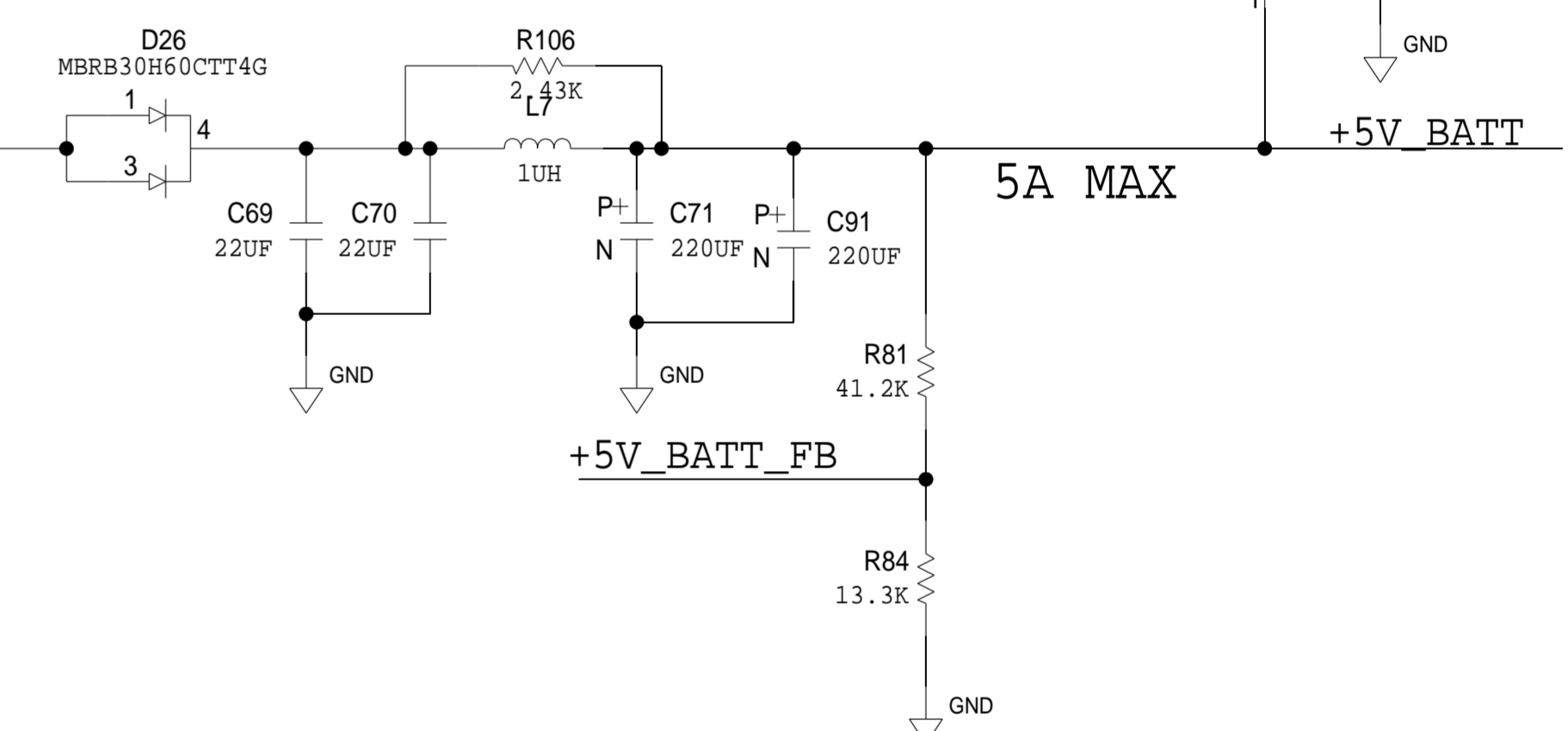

POE	EXT	SYSTEM STATE	BATTERY SWITCHER	BATTERY CHARGER	POWER SOURCE
OFF	OFF	OFF	OFF	OFF	NONE
OFF	OFF	ON	ON	OFF	BATTERY
ON	OFF	ON	ON	ON	POE
ON	OFF	OFF	OFF	ON	POE
OFF	ON	ON	ON	ON	EXT
OFF	ON	OFF	OFF	ON	EXT
ON	ON	ON	ON	ON	POE

SYSTEM STATE: IS THE SYSTEM ON, OR OFF, DEFINED BY NODE "SYSTEM\_ENABLE"  
 ADP1621 SDSN PIN: IS THE BATTERY BEING USED OR NOT? (DO I NEED 5V, OR NOT?)  
 OK TO CHARGE : IF POE AND EXT +5V ARE NOT APPLIED, THE CHARGING SWITCHER (ADP5061) HAS NO POWER.

	<b>SCHEMATIC</b>		
	HW TYPE : Customer Evaluation Z Product(s) : N/A : N/A		
DESIGN VIEW <DESIGN_VIEW>	DRAWING NO. 02_042967	REV D	
PTD ENGINEER N. WILSON	SIZE D	SCALE 1:1	SHEET 9 OF 13

REVISIONS			
REV	DESCRIPTION	DATE	APPROVED

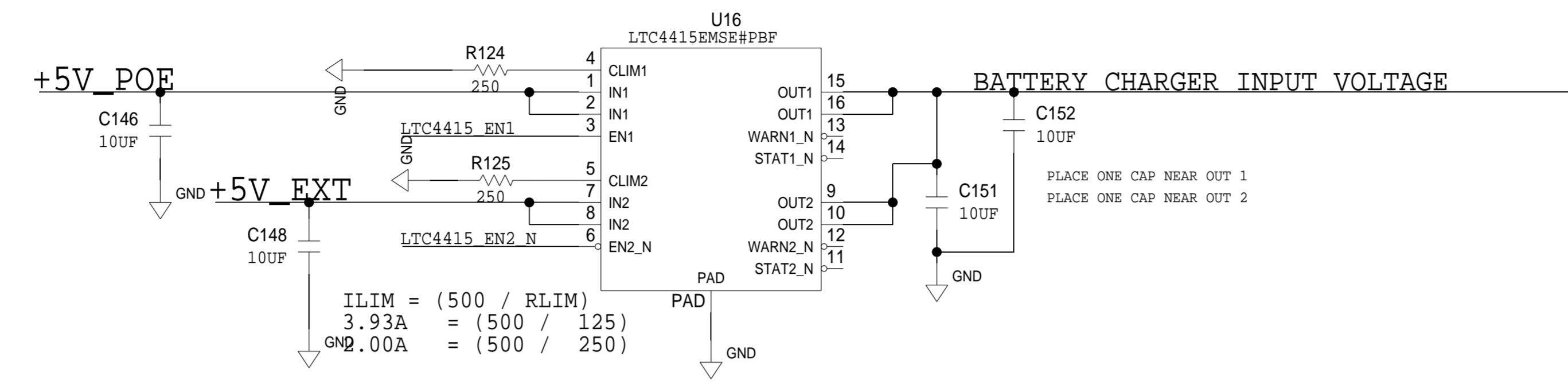
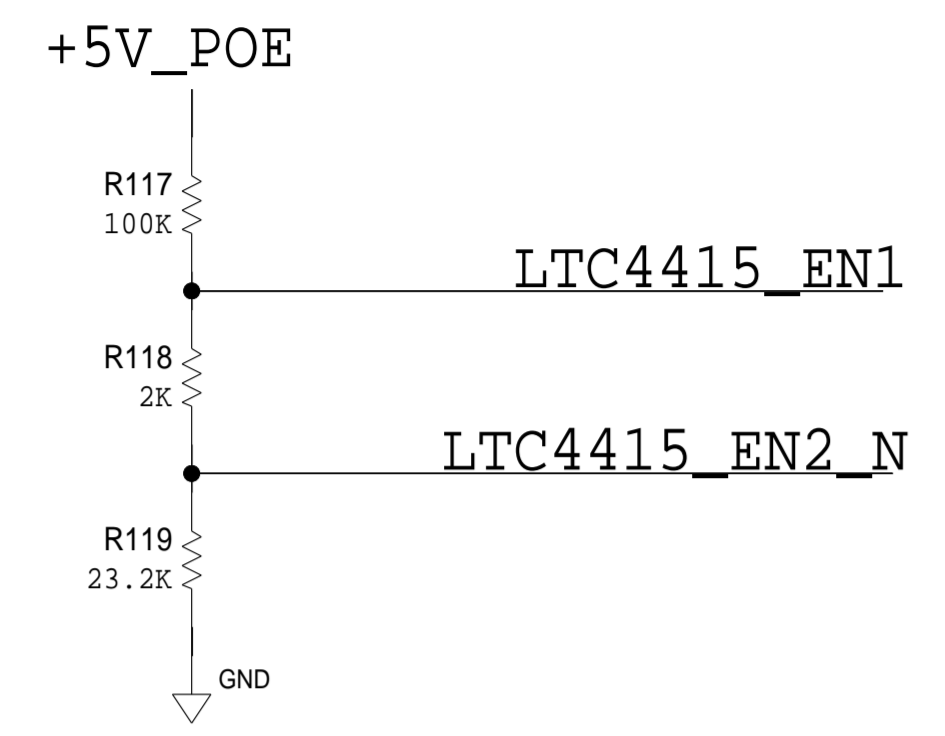

## LI-ION BATTERY CHARGING

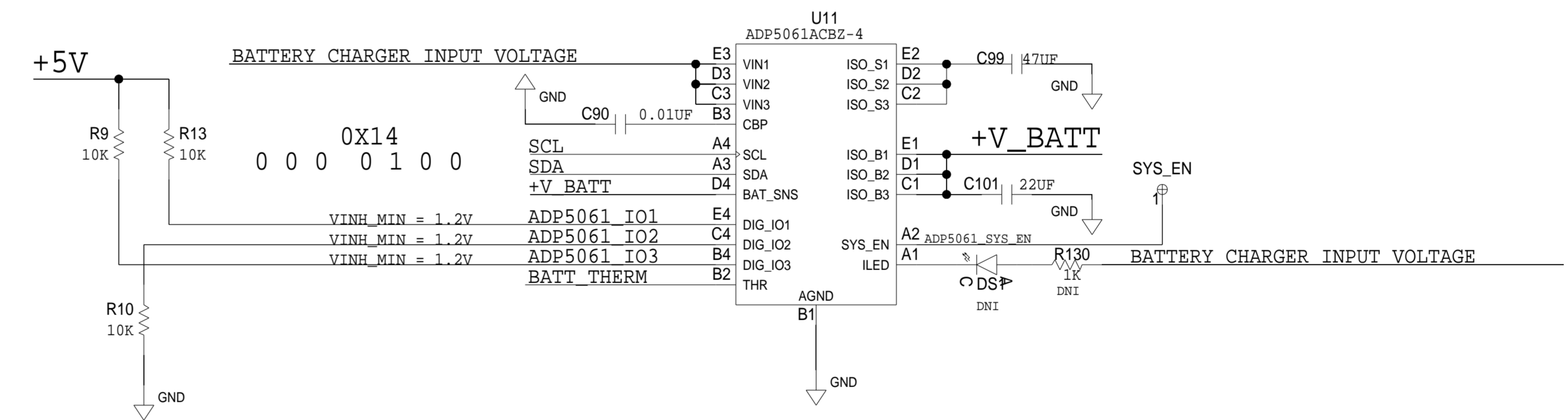

CLOCK OSCILLATOR = 3MHZ

DIG IO1 = SETS CURRENT LIMIT  
 LOW = 100MA  
 HIGH = 500MA

DIG IO2 = ENABLE  
 LOW = NORMAL OPERATION  
 HIGH = LDO/CHARGER DISABLED

DIG IO3 = ENABLE CHARGING  
 LOW = CHARGING DISABLED  
 HIGH = CHARGING ENABLED

	<b>SCHEMATIC</b>		
	HW TYPE : Customer Evaluation Z Product(s) : N/A : N/A		
	DESIGN VIEW <DESIGN_VIEW>	DRAWING NO. 02_042967	REV D
PTD ENGINEER N. WILSON	SIZE D	SCALE 1:1	SHEET 10 OF 13

REVISIONS			
REV	DESCRIPTION	DATE	APPROVED

P9  
FTSH-103-01-F-D

SWITCH PIN 1	1
RED ANODE	2
COMMON CATHODE	3
GREEN ANODE	4
BLUE ANODE	5
SWITCH PIN 2	6

SWITCH PN - LITE  
PV0H240SS-331

HTTP://SPEC\_SHEETS.E-SWITCH.COM/SPECS/52-PV6F240SS3R1.PDF

CABLE PN  
FFSD-03-S-02.00-01  
8.6MM DIAGONAL  
9.55MM DIAGONAL

# PUSH BUTTON

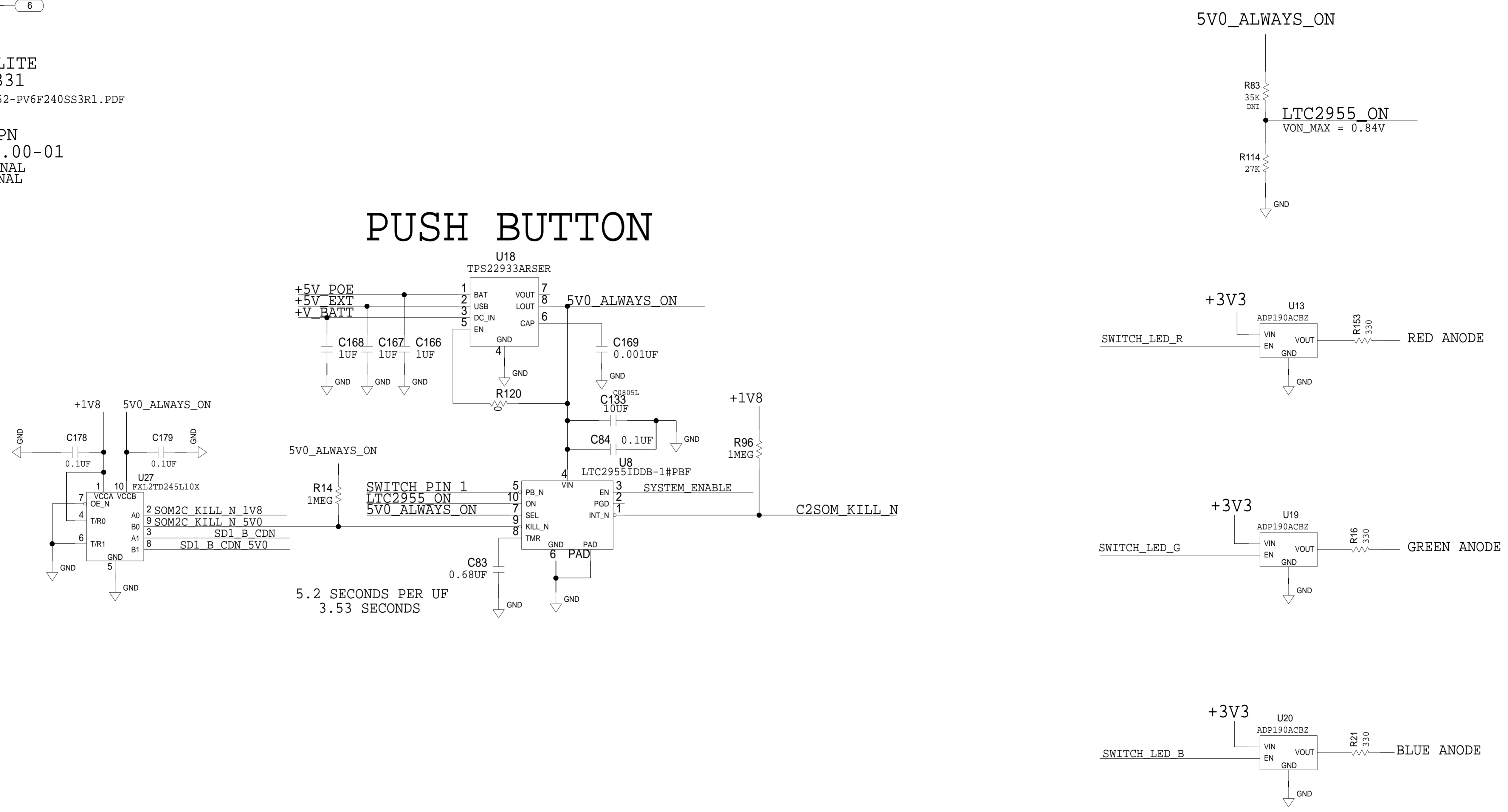

	<b>SCHEMATIC</b>		
	HW TYPE : Customer Evaluation Z		
	Product(s) : N/A		
	: N/A		
DESIGN VIEW <DESIGN_VIEW>	DRAWING NO. 02_042967	REV D	
PTD ENGINEER N. WILSON	SIZE D	SCALE 1:1	SHEET 11 OF 13

REVISIONS			
REV	DESCRIPTION	DATE	APPROVED

# POWER SOURCE SELECTION

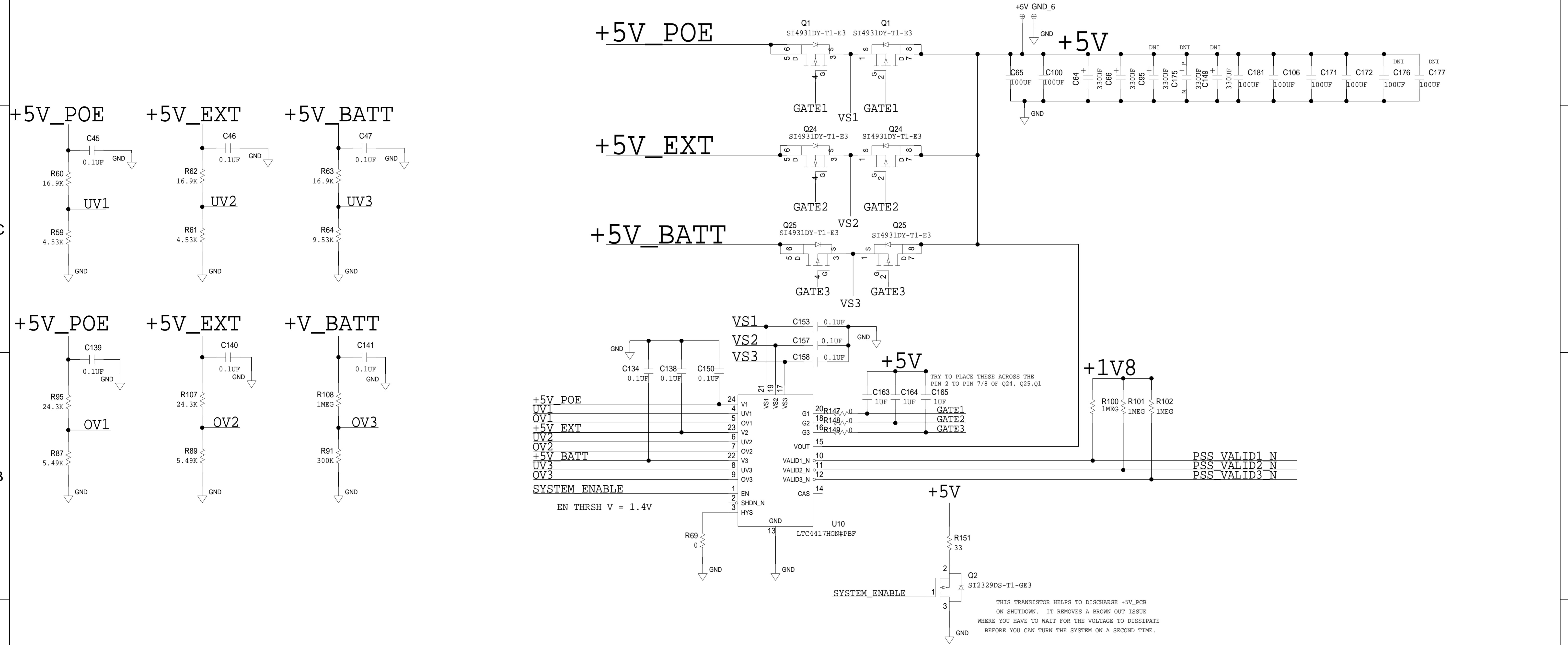

SCHEMATIC			
HW TYPE : Customer Evaluation Z Product(s) : N/A : N/A		DRAWING NO. 02_042967	
DESIGN VIEW <DESIGN_VIEW>		REV D	
PTD ENGINEER N. WILSON		SIZE D	SCALE 1:1
		SHEET 12 OF 13	

THIS DRAWING IS THE PROPERTY OF ANALOG DEVICES INC. IT IS NOT TO BE REPRODUCED OR COPIED, IN WHOLE OR IN PART, OR USED IN FURNISHING INFORMATION TO OTHERS, OR FOR ANY OTHER PURPOSE DETRIMENTAL TO THE INTERESTS OF ANALOG DEVICES. THE EQUIPMENT SHOWN HEREON MAY BE PROTECTED BY PATENTS OWNED OR CONTROLLED BY ANALOG DEVICES.

THIS TRANSISTOR HELPS TO DISCHARGE +5V\_PCB ON SHUTDOWN. IT REMOVES A BROWN OUT ISSUE WHERE YOU HAVE TO WAIT FOR THE VOLTAGE TO DISSIPATE BEFORE YOU CAN TURN THE SYSTEM ON A SECOND TIME.

# POWER SEQUENCE

REVISIONS			
REV	DESCRIPTION	DATE	APPROVED

+5V\_POE  
+5V\_BATT  
+5V\_EXT

VIN\_HDR  
+5V\_PCB

+3V3\_PCB

+1V8\_PCB

VCCIO\_EN

PG\_MODULE

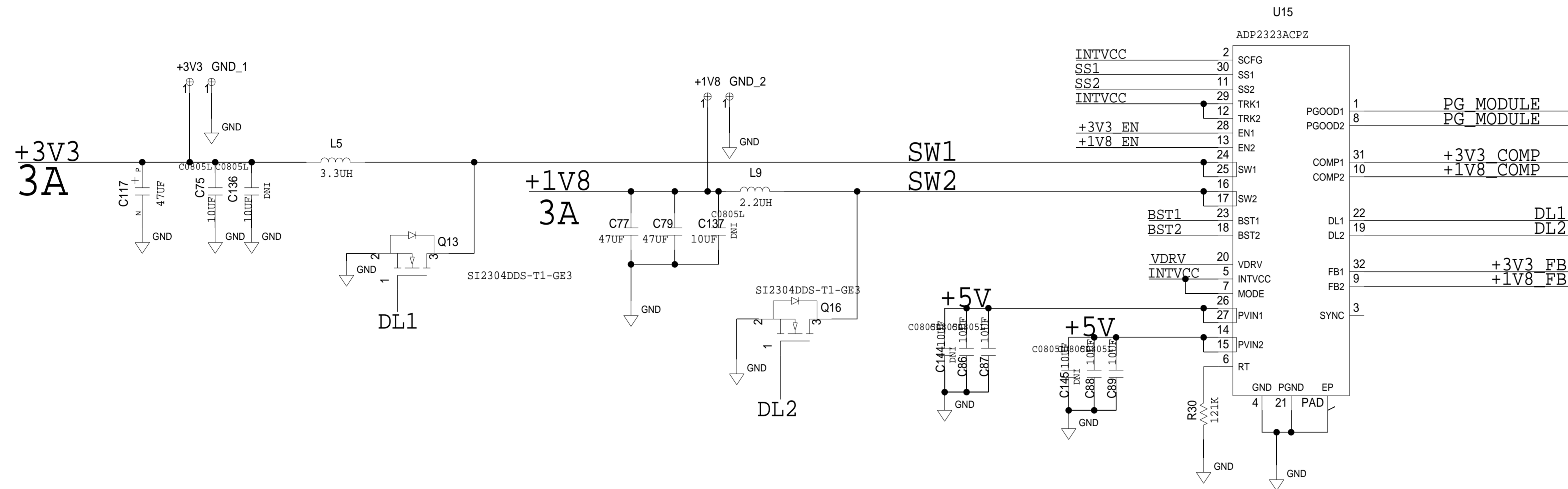

F<sub>SW</sub> = 500KHZ

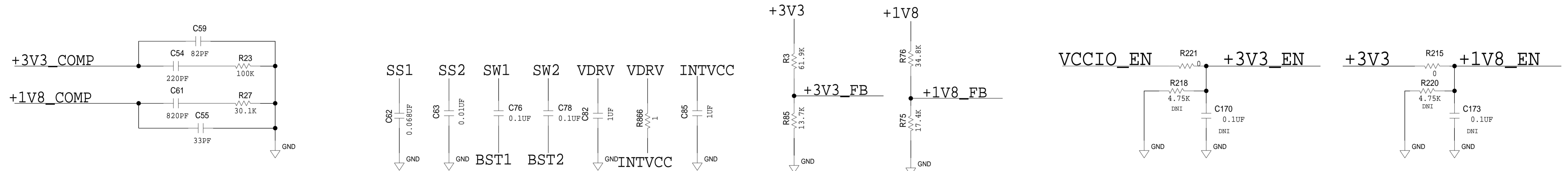

$$CH1\_TSS = (0.6 * 82NF) / (3.5UA) = 14MS$$

$$CH2\_TSS = (0.6 * 10NF) / (3.5UA) = 1.7MS$$

SCHEMATIC			
ANALOG DEVICES		HW TYPE : Customer Evaluation Z Product(s) : N/A : N/A	
DESIGN VIEW <DESIGN_VIEW>	DRAWING NO. 02_042967	REV D	
PTD ENGINEER N. WILSON	SIZE D	SCALE 1:1	SHEET 13 OF 13