

8 7 6 5 4 3 2 1

THIS DRAWING IS THE PROPERTY OF ANALOG DEVICES INC. IT IS NOT TO BE REPRODUCED OR COPIED, IN WHOLE OR IN PART, OR USED IN FURNISHING INFORMATION TO OTHERS, OR FOR ANY OTHER PURPOSE DETRIMENTAL TO THE INTERESTS OF ANALOG DEVICES. THE EQUIPMENT SHOWN HEREON MAY BE PROTECTED BY PATENTS OWNED OR CONTROLLED BY ANALOG DEVICES.

REVISIONS			
REV	DESCRIPTION	DATE	APPROVED
A	INITIAL RELEASE	02AUG23	Z. ARCEO
B	ECR-116325	15AUG23	Z. ARCEO
C	ECR-117464	08NOV23	Z. ARCEO
D	ECR-118553	08JAN24	Z. ARCEO

PA ARRAY CONTROLLER BOARD

- PAGE 1 - FRONT PAGE
- PAGE 2 - SYSTEM ARCHITECTURE
- PAGE 3 - LTC7000 FAULT DETECTOR - GAN A5M36TG140
- PAGE 4 - LTC7000 FAULT DETECTOR
- PAGE 5 - LTC7000 FAULT DETECTOR - GAN GTRB384608FC-V1
- PAGE 6 - POWER SUPPLY MANAGEMENT
- PAGE 7 - AD3552R DAC - GAN A5M36TG140
- PAGE 8 - AD3552R DAC - LD MOS A5M36TG140
- PAGE 9 - AD3552R DAC - GAN GTRB384608FC-V1
- PAGE 10 - MAX32666 MICROCONTROLLER
- PAGE 11 - PINS, CONNECTORS AND HEADERS
- PAGE 12 - LTC2992 VI MONITOR - GAN A5M35TG140
- PAGE 13 - LTC2992 VI MONITOR - GAN GTRB384608FC-V1
- PAGE 14 - MAX6516 TEMPERATURE MONITOR

TEMPLATE ENGINEER BILLY PHILLIPS	DATE 07APR21	SCHEMATIC		
HARDWARE SERVICES BOB MACDONALD	07APR21			
HARDWARE SYSTEMS DAVE WILLIAMS	07APR21	HW TYPE : Customer Evaluation		
TEST ENGINEER N/A	N/A	Product(s): AD3552R, MAX32666 : LTC7000		
COMPONENT ENGINEER ADGT LIBRARY	02AUG23	PACKAGE : 0-lead BodySize PackageType-family : Pitch-pitch StyleVendor Style		
TEST PROCESS N/A	N/A	<User Define>		
HARDWARE RELEASE C. PASIA	08NOV23	<User Define>		
DESIGNER C. PASIA	08NOV23	MASTER PROJECT TEMPLATE TBD	TESTER TEMPLATE 067676_b	DRAWING NO. 02_079905
PTD ENGINEER Z. ARCEO	08NOV23	REV. D		
CHECKER N/A	N/A	UNLESS OTHERWISE SPECIFIED DIMENSIONS ARE IN INCHES		
		TOLERANCES		
		DECIMALS X.XX +0.010 X.XXX +0.005	FRACTIONS +1/32	ANGLES +2
		SIZE D	SCALE 1:1	CODE ID NO. CodeID
		SHEET 1		OF 14

SYSTEM ARCHITECTURE

REVISIONS			
REV	DESCRIPTION	DATE	APPROVED

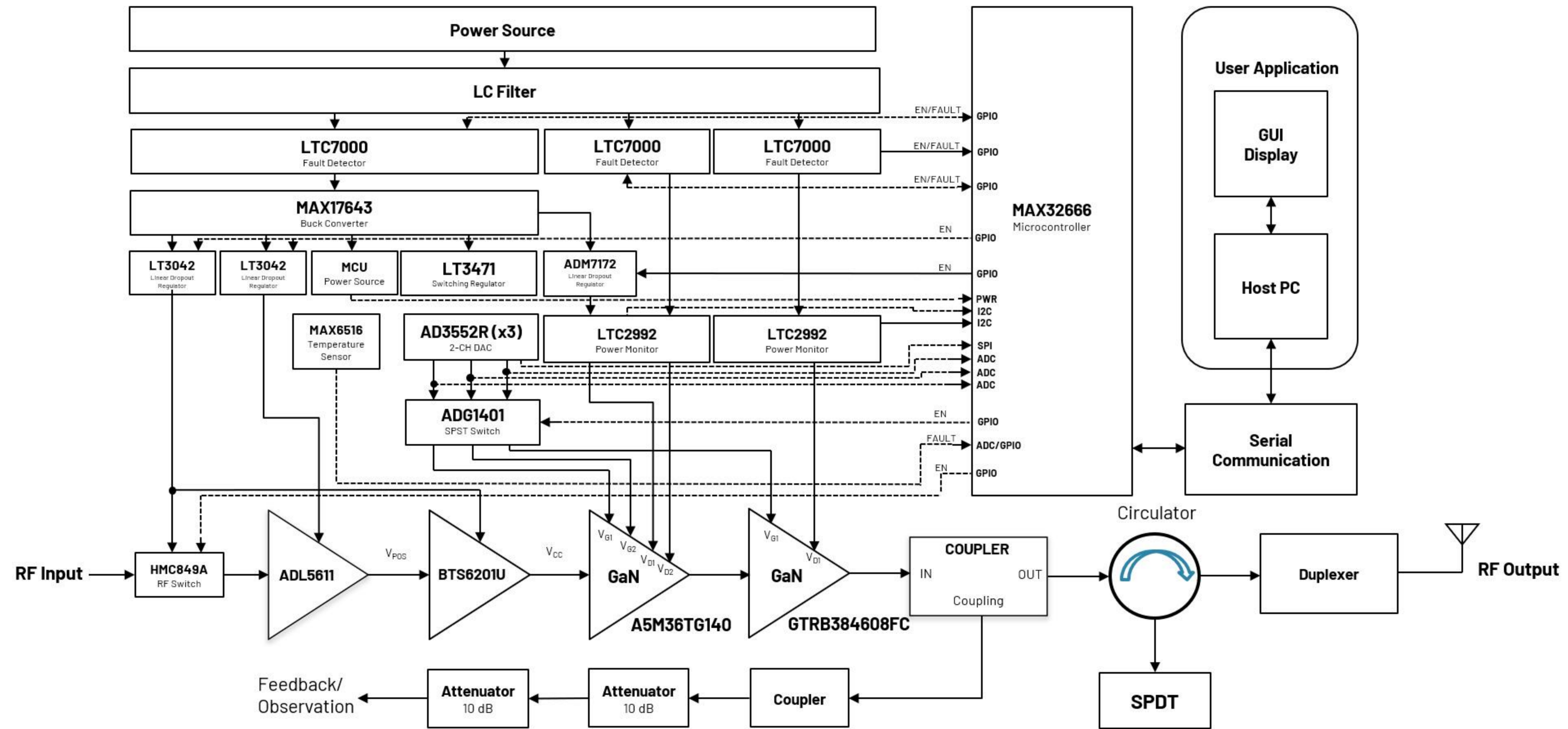

	SCHEMATIC		
	HW TYPE : Customer Evaluation Product(s): AD3552R, MAX32666 : LTC7000		
	DESIGN VIEW <DESIGN_VIEW>	DRAWING NO. 02_079905	REV D
	PTD ENGINEER Z. ARCEO	SIZE D	SCALE 1:1
		SHEET 2 OF 14	

REVISIONS			
REV	DESCRIPTION	DATE	APPROVED

FAULT DETECTION CIRCUIT

LTC7000

PROTECTION CIRCUIT FOR GAN A5M36TG140

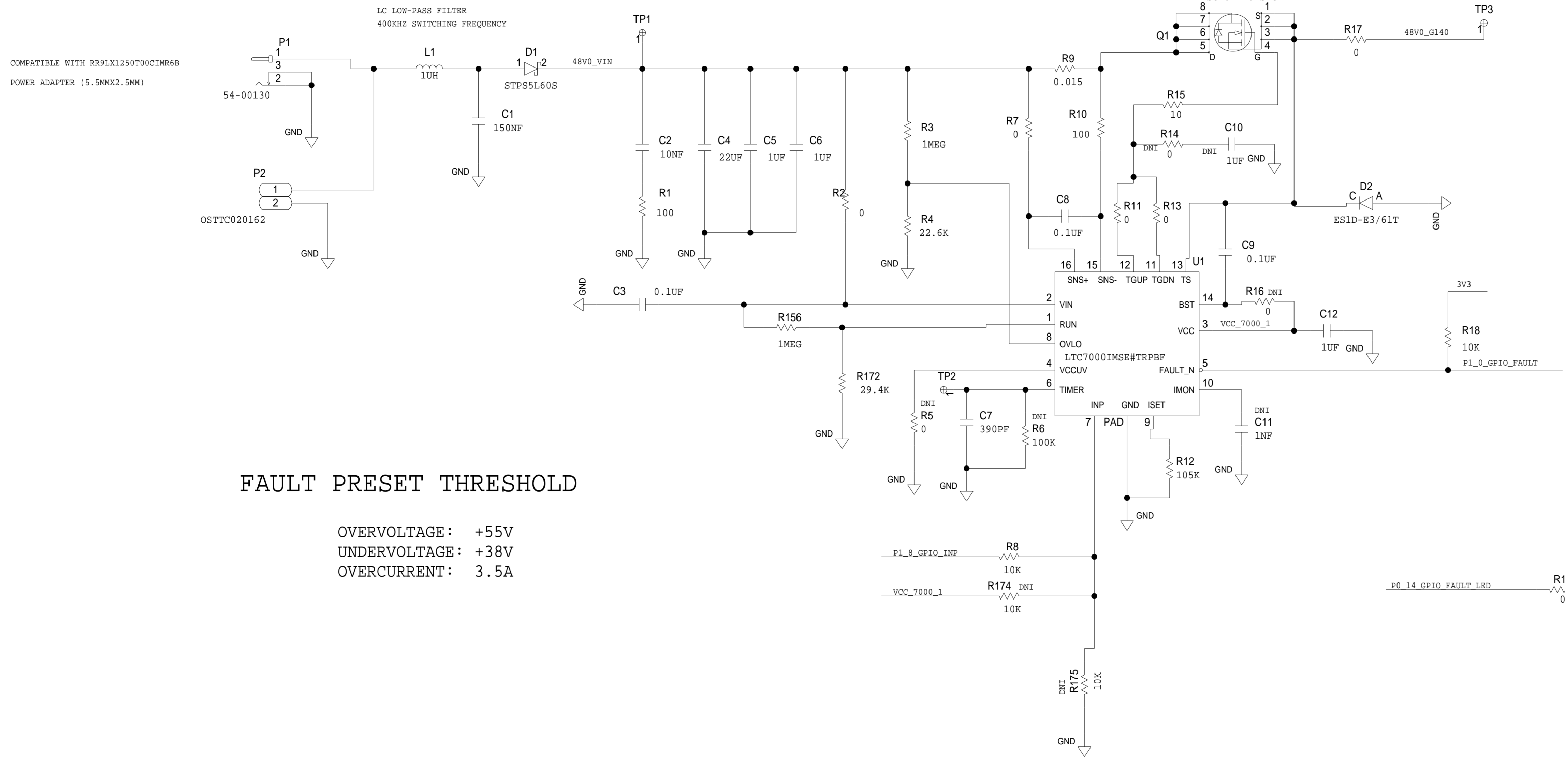

FAULT PRESET THRESHOLD

- OVERVOLTAGE : +55V
- UNDERVOLTAGE : +38V
- OVERCURRENT : 3.5A

OV, OC, UV FAULT LED

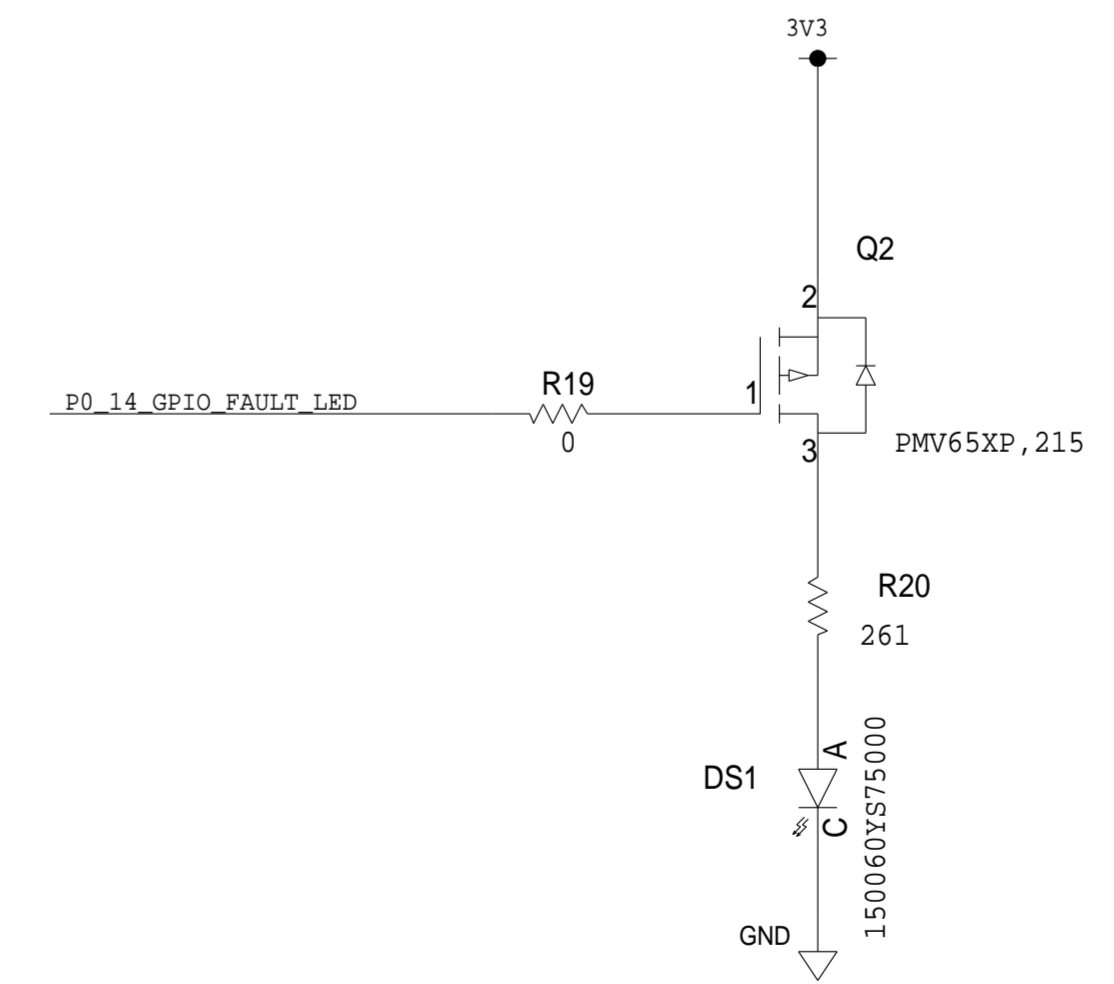

	SCHEMATIC		
	HW TYPE : Customer Evaluation Product(s) : AD3552R, MAX32666 : LTC7000		
DESIGN VIEW <DESIGN_VIEW>	DRAWING NO. 02_079905	REV D	
PTD ENGINEER Z. ARCEO	SIZE D	SCALE 1:1	SHEET 3 OF 14

FAULT DETECTION CIRCUIT

LTC7000

SYSTEM'S PROTECTION CIRCUIT

REVISIONS			
REV	DESCRIPTION	DATE	APPROVED

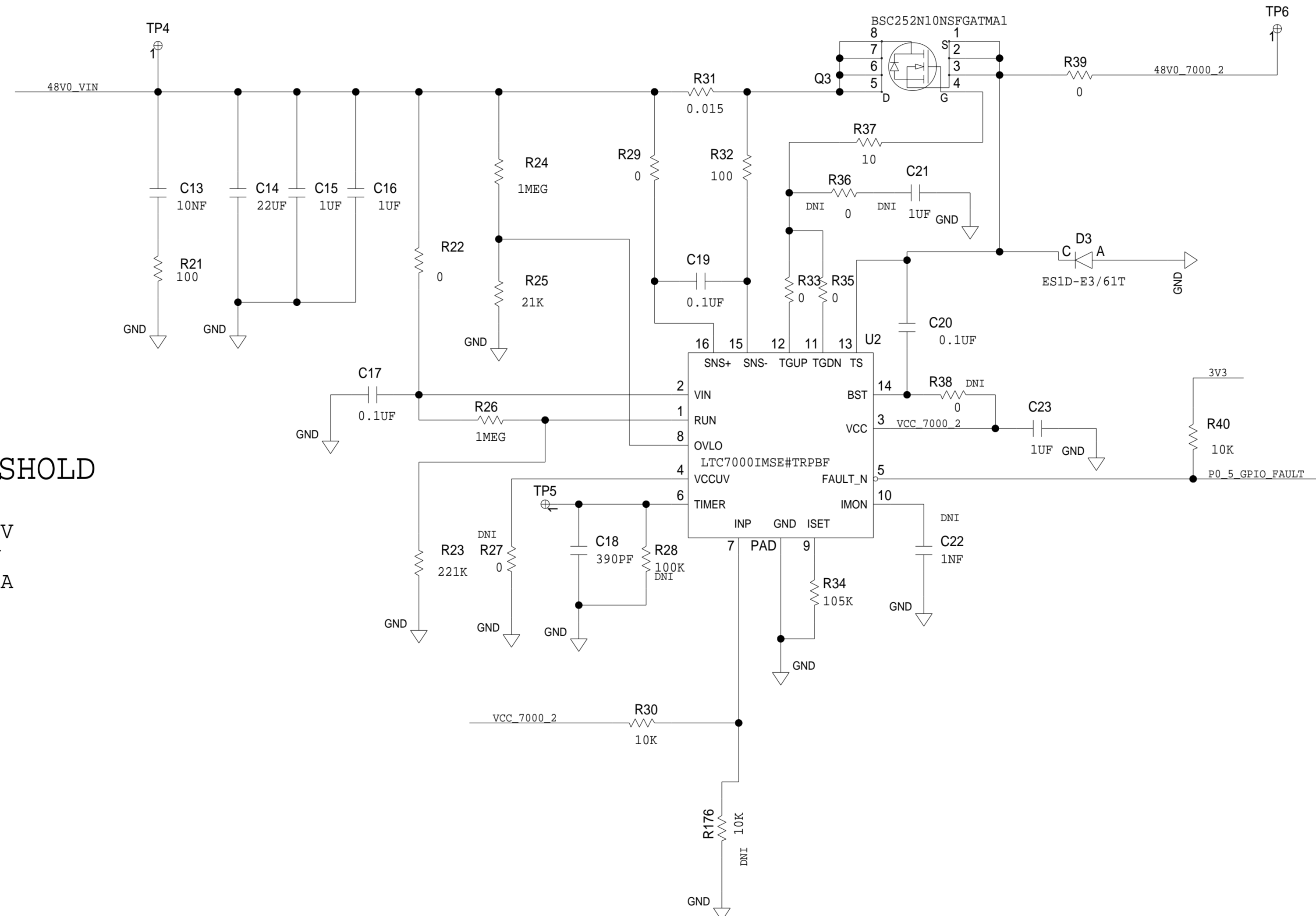

FAULT PRESET THRESHOLD

OVERVOLTAGE : +60V
 UNDERVOLTAGE : +6V
 OVERCURRENT : 3.5A

	SCHEMATIC		
	HW TYPE : Customer Evaluation Product(s) : AD3552R, MAX32666 : LTC7000		
DESIGN VIEW <DESIGN_VIEW>	DRAWING NO. 02_079905	REV D	
PTD ENGINEER Z. ARCEO	SIZE D	SCALE 1:1	SHEET 4 OF 14

REVISIONS			
REV	DESCRIPTION	DATE	APPROVED

FAULT DETECTION CIRCUIT

LTC7000

PROTECTION CIRCUIT FOR GAN GTRB384608FC-V1

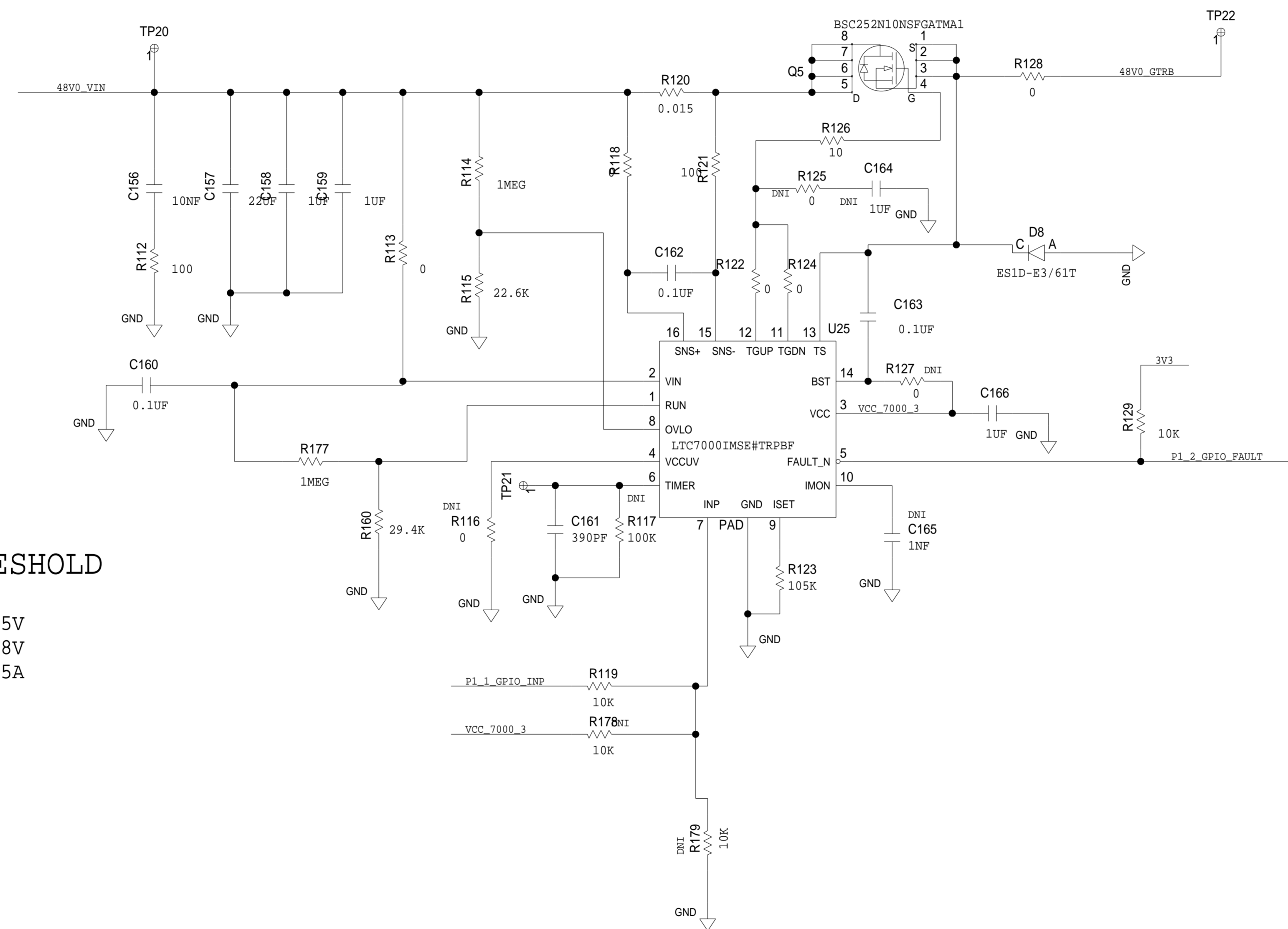

FAULT PRESET THRESHOLD

OVERVOLTAGE: +55V
 UNDERVOLTAGE: +38V
 OVERCURRENT: 3.5A

	SCHEMATIC		
	HW TYPE : Customer Evaluation Product(s): AD3552R, MAX32666 : LTC7000		
DESIGN VIEW <DESIGN_VIEW>	DRAWING NO. 02_079905	REV D	
PTD ENGINEER Z. ARCEO	SIZE D	SCALE 1:1	SHEET 5 OF 14

POWER SUPPLY MANAGEMENT

REVISIONS			
REV	DESCRIPTION	DATE	APPROVED

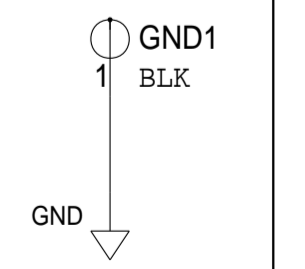
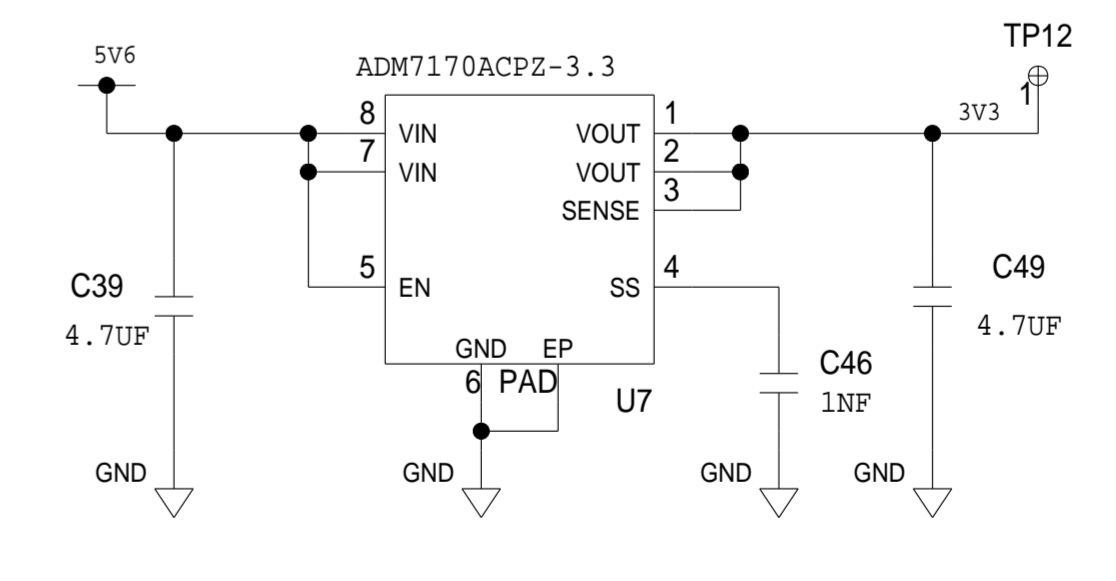
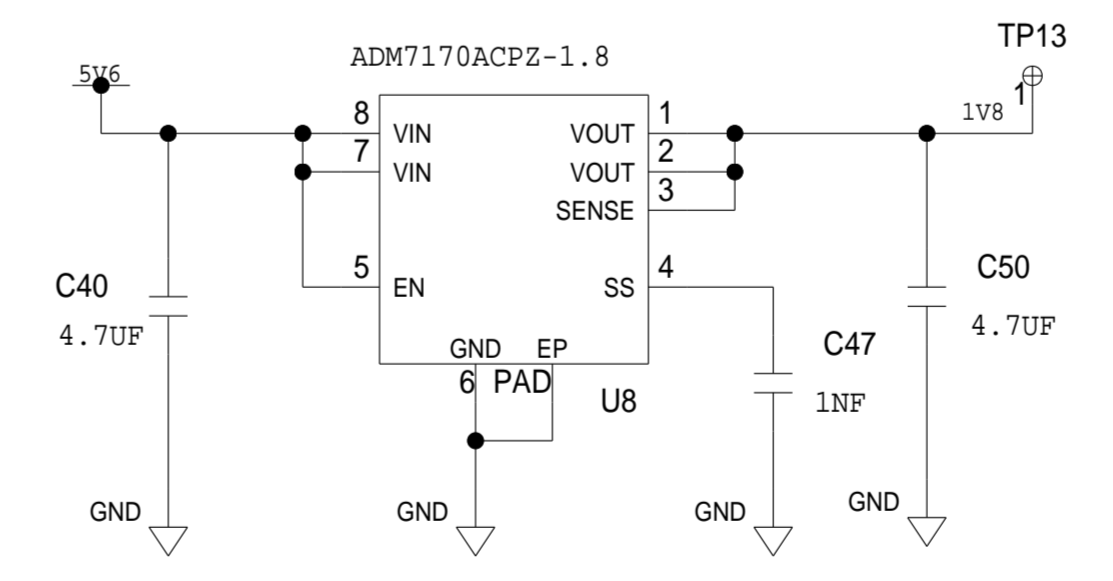
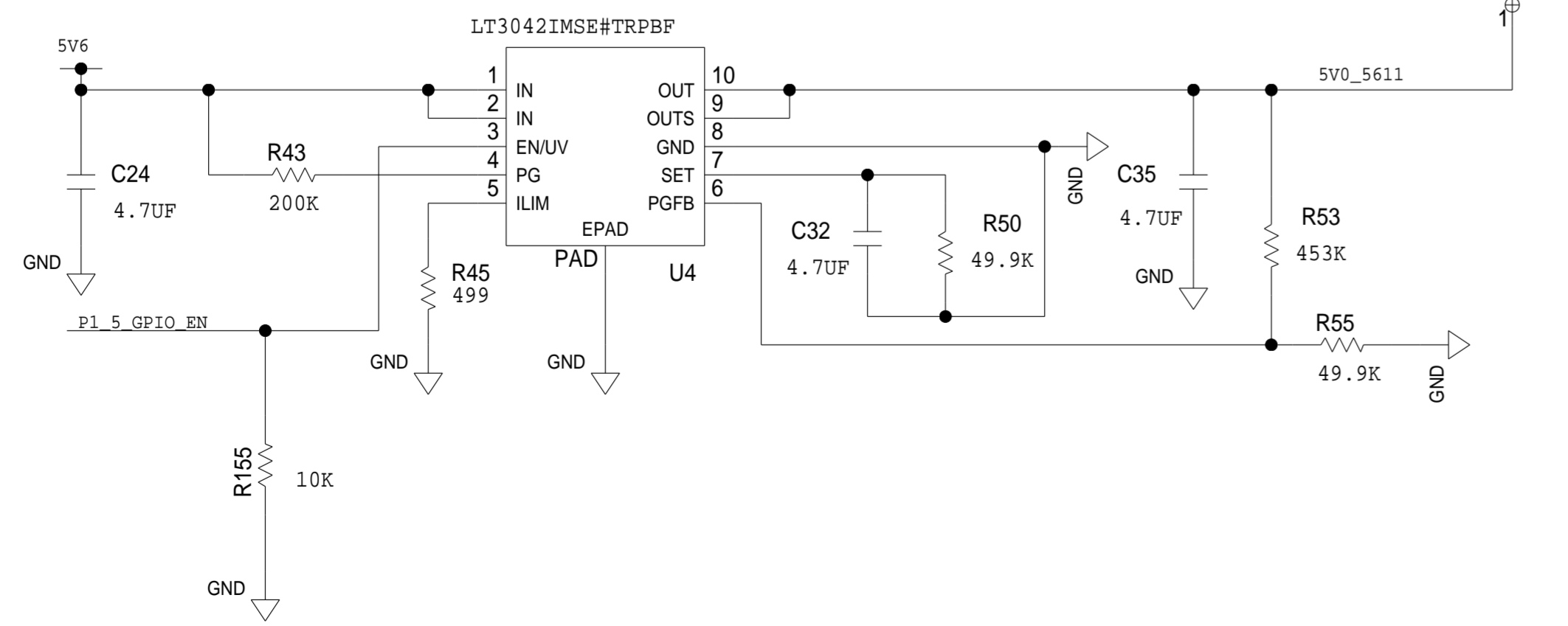
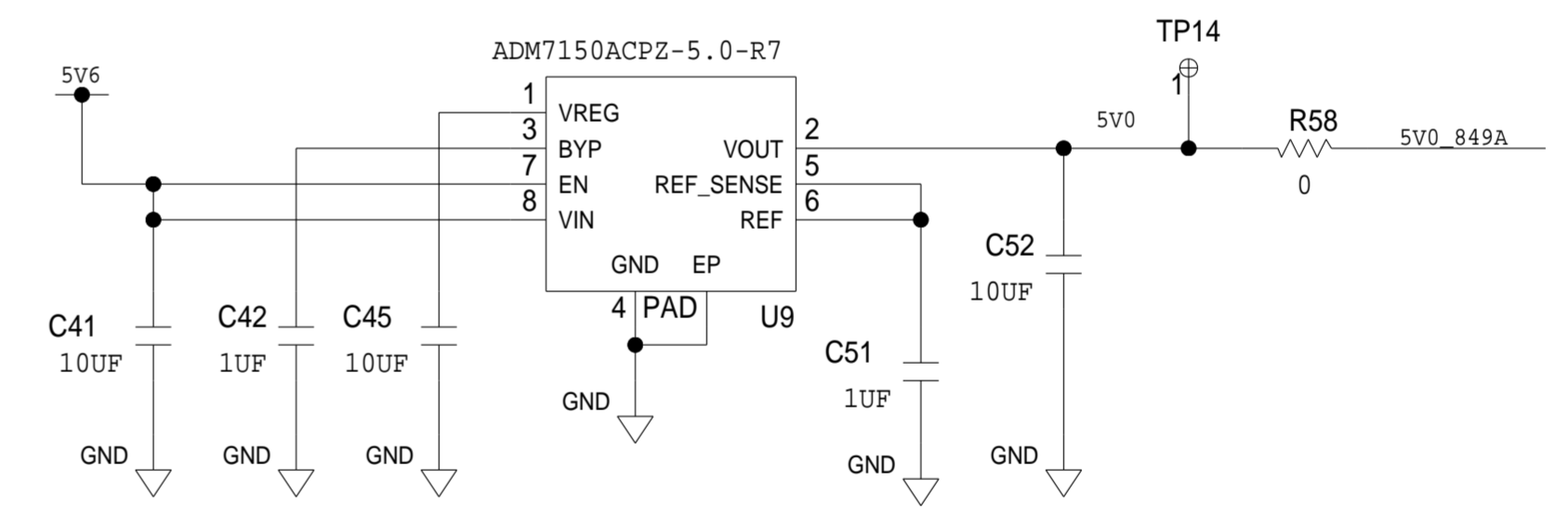
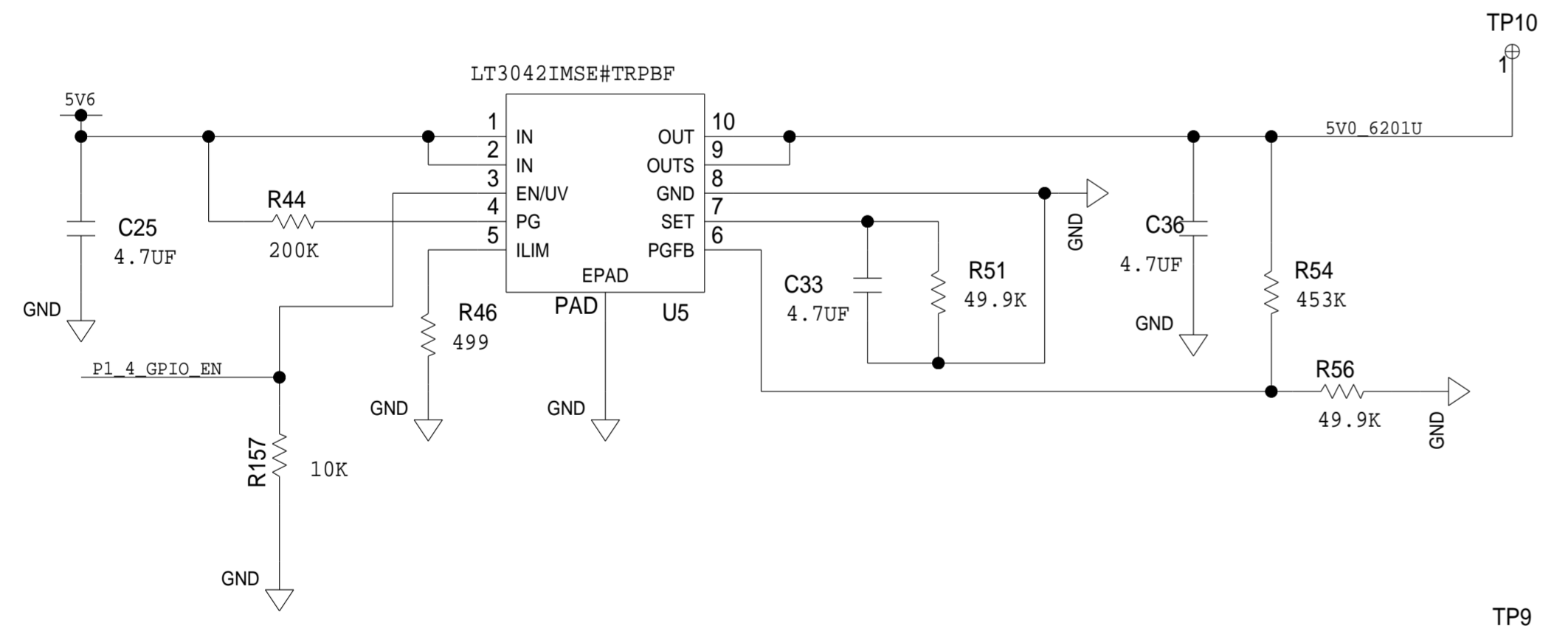
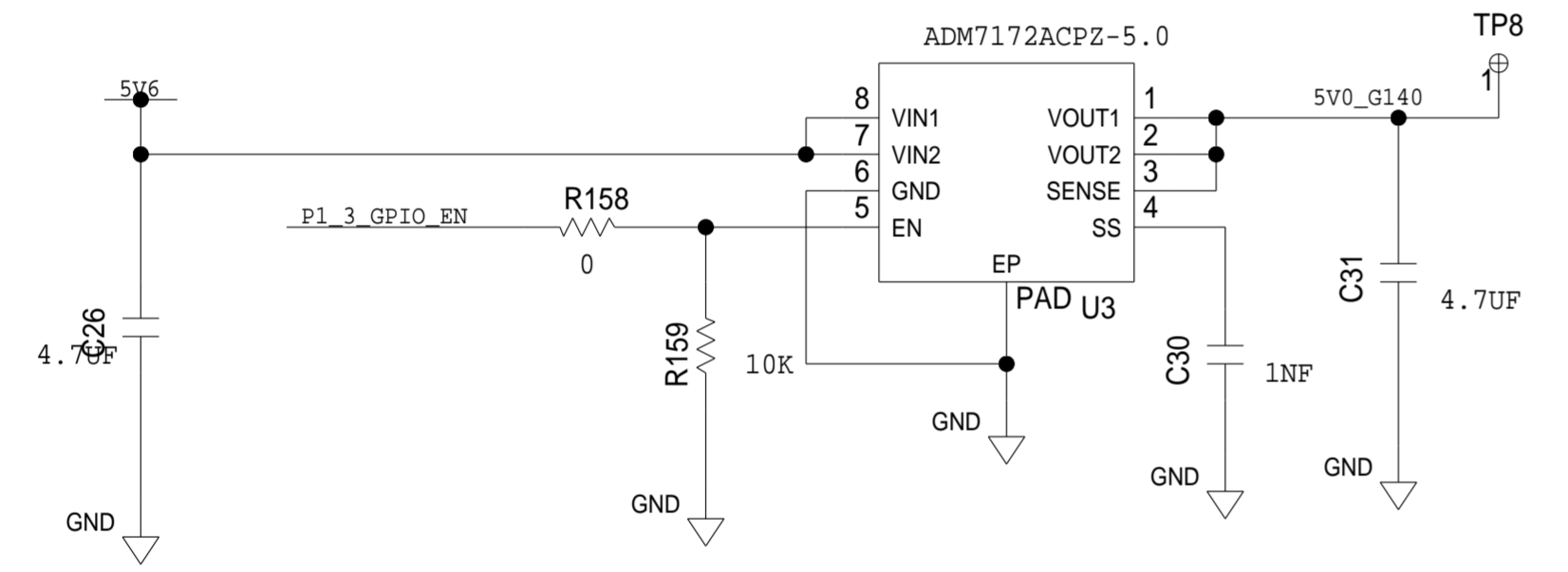
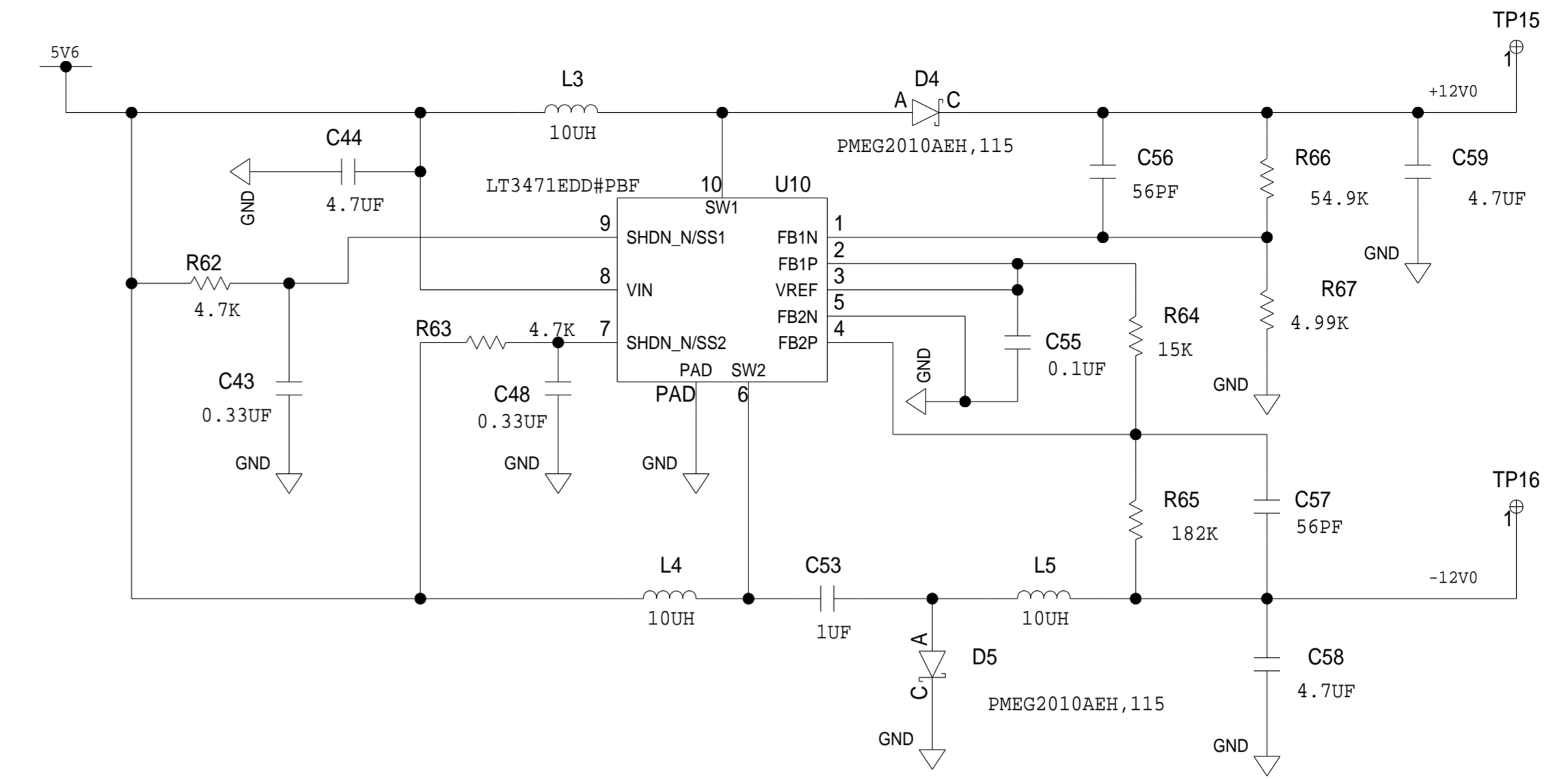
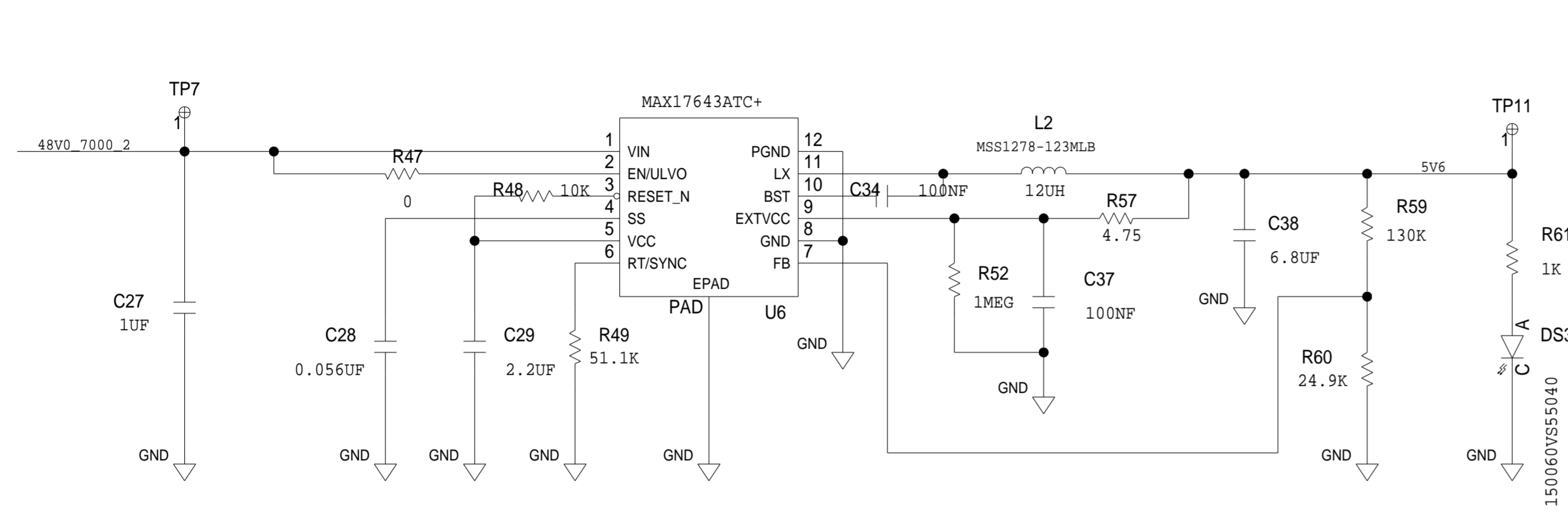

	SCHEMATIC HW TYPE : Customer Evaluation Product(s) : AD3552R, MAX32666 : LTC7000		
	DESIGN VIEW <DESIGN_VIEW>	DRAWING NO. 02_079905	REV D
PTD ENGINEER Z. ARCEO	SIZE D	SCALE 1:1	SHEET 6 OF 14

AD3552R - DUAL CHANNEL DAC 0

GATE VOLTAGE BIASING FOR GAN A5M36TG140

REVISIONS			
REV	DESCRIPTION	DATE	APPROVED

Gate Voltage Range (V)	ADC Input Range (V)
-10	0.0066
0	0.5996
10	1.1926

ADC REF: 1.22V INTERNAL

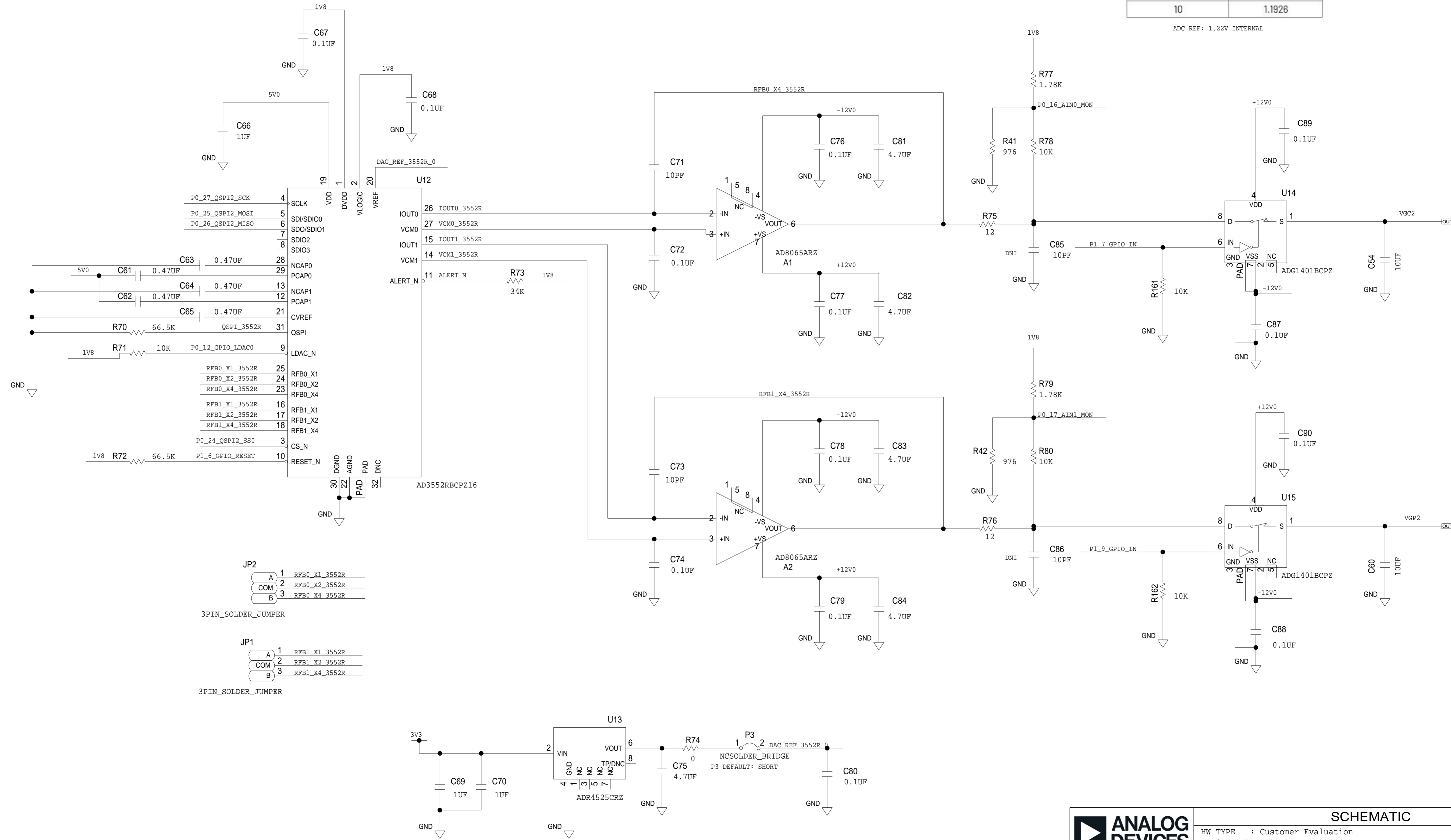

P0_27_QSPI2_SCK	4	SCLK	19	VDD
P0_25_QSPI2_MOSI	5	SDI/SDIO0	2	DVDD
P0_26_QSPI2_MISO	6	SDO/SDIO1	20	VLOGIC
	7	SDIO2		VREF
	8	SDIO3		
	28	NCAP0		
	29	PCAP0		
	13	NCAP1		
	12	PCAP1		
	21	CVREF		
	31	QSPI		
	9	LDAC_N		
	25	RFB0_X1		
	24	RFB0_X2		
	23	RFB0_X4		
	16	RFB1_X1		
	17	RFB1_X2		
	18	RFB1_X4		
	3	CS_N		
	10	RESET_N		

JP2

1	RFB0_X1_3552R
2	RFB0_X2_3552R
3	RFB0_X4_3552R

3PIN_SOLDER_JUMPER

JP1

1	RFB1_X1_3552R
2	RFB1_X2_3552R
3	RFB1_X4_3552R

3PIN_SOLDER_JUMPER

	SCHEMATIC		
	HW TYPE : Customer Evaluation Product(s) : AD3552R, MAX32666 : LTC7000		
DESIGN VIEW <DESIGN_VIEW>	DRAWING NO. 02_079905	REV D	
PTD ENGINEER Z. ARCEO	SIZE D	SCALE 1:1	SHEET 7 OF 14

AD3552R - DUAL CHANNEL DAC 1

GATE VOLTAGE BIASING FOR LDMOS A5M36TG140

REVISIONS			
REV	DESCRIPTION	DATE	APPROVED

Gate Voltage Range (V)	ADC Input Range (V)
-10	0.0066
0	0.5996
10	1.1926

ADC REF: 1.22V INTERNAL

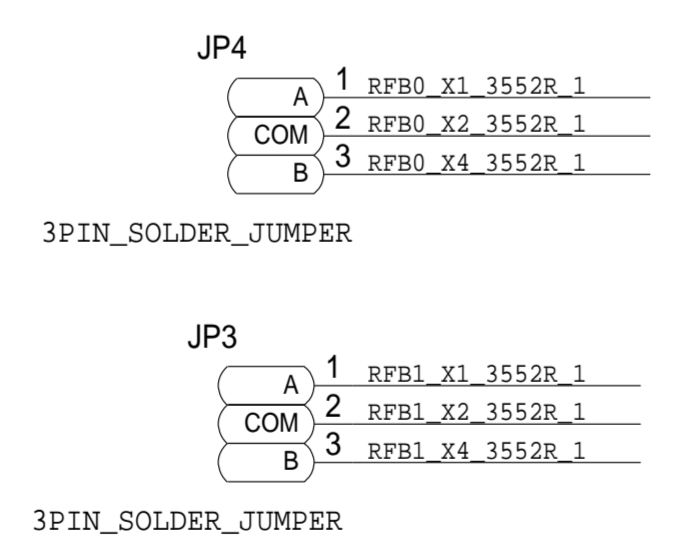
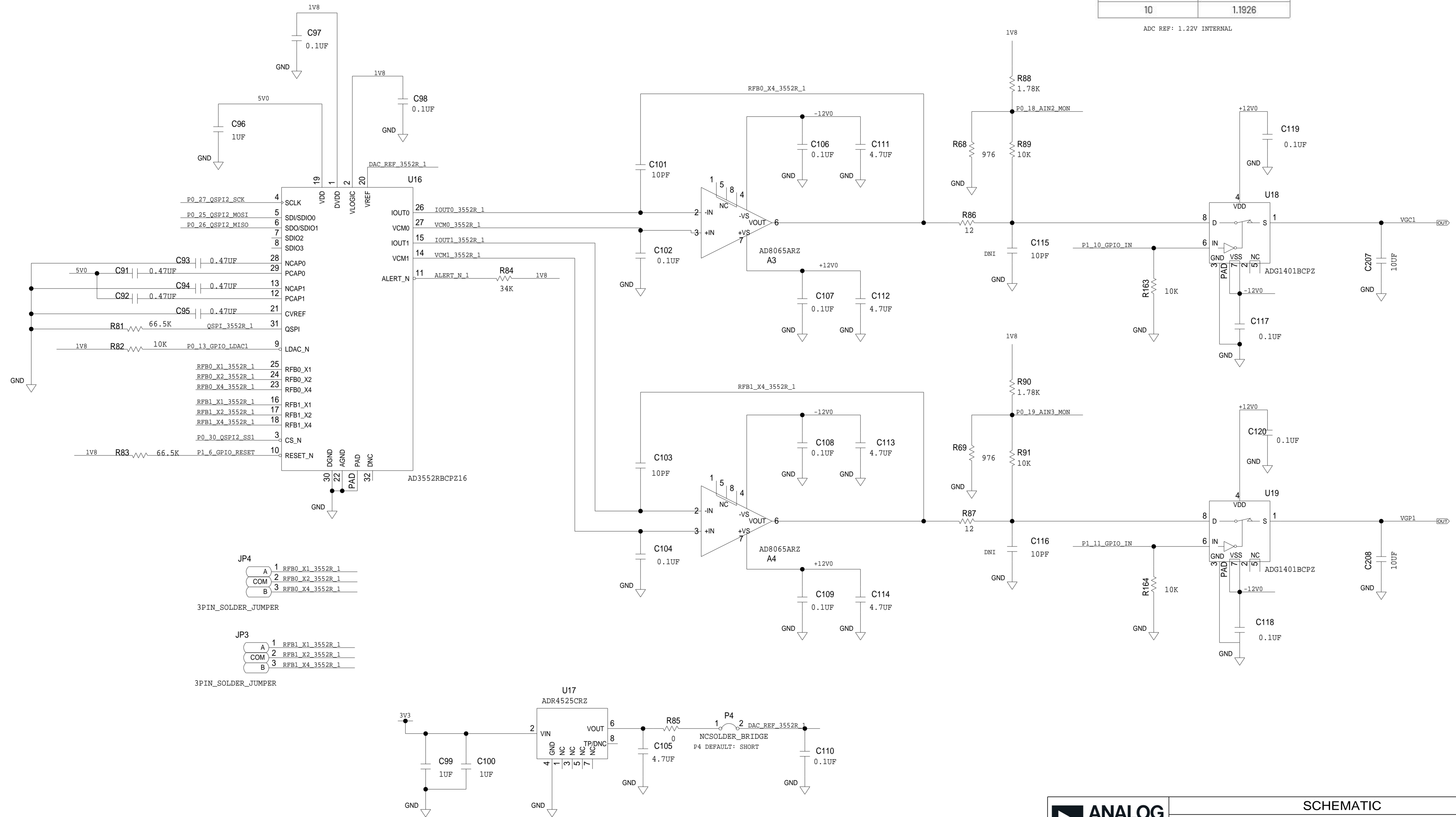

	SCHEMATIC		
	HW TYPE : Customer Evaluation Product(s) : AD3552R, MAX32666 : LTC7000		
DESIGN VIEW <DESIGN_VIEW>	DRAWING NO. 02_079905	REV D	
PTD ENGINEER Z. ARCEO	SIZE D	SCALE 1:1	SHEET 8 OF 14

AD3552R - DUAL CHANNEL DAC 2

GATE VOLTAGE BIASING FOR GAN GTRB384608FC-V1

REVISIONS			
REV	DESCRIPTION	DATE	APPROVED

Gate Voltage Range (V)	ADC Input Range (V)
-10	0.0068
0	0.5996
10	1.1926

ADC REF: 1.22V INTERNAL

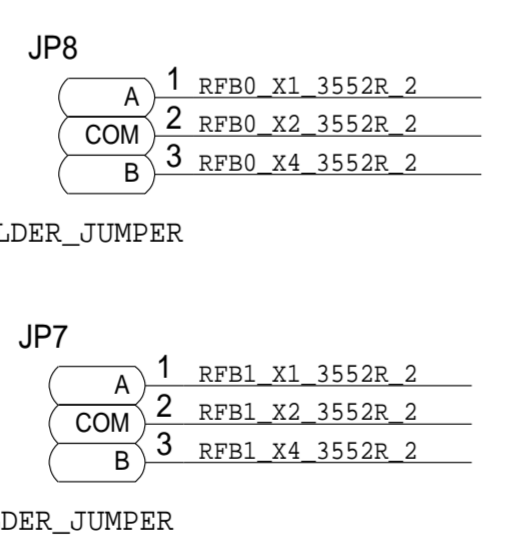
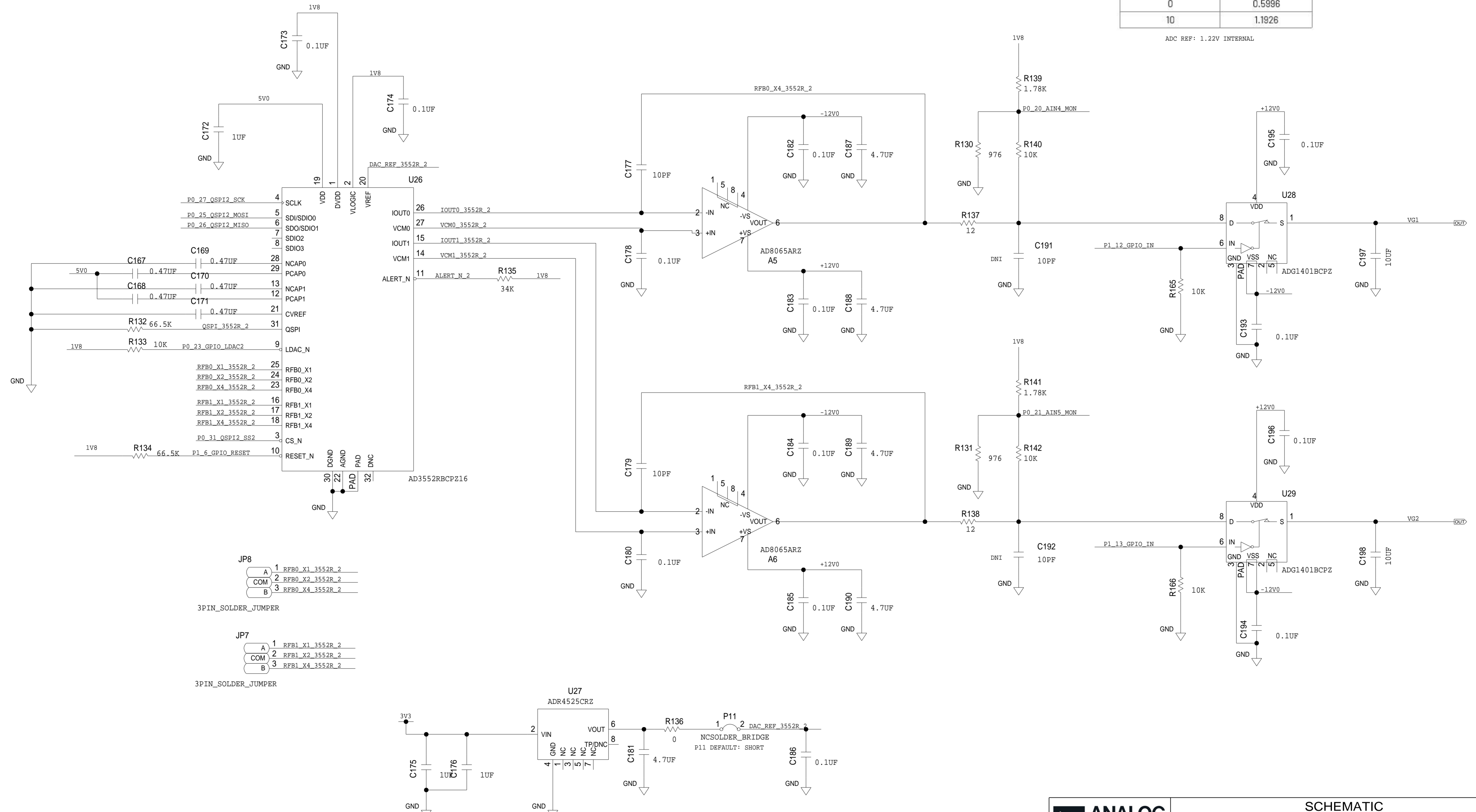

	SCHEMATIC HW TYPE : Customer Evaluation Product(s) : AD3552R, MAX32666 : LTC7000		
	DESIGN VIEW <DESIGN_VIEW>	DRAWING NO. 02_079905	REV D
PTD ENGINEER Z. ARCEO	SIZE D	SCALE 1:1	SHEET 9 OF 14

MAX32666

MICROCONTROLLER

REVISIONS			
REV	DESCRIPTION	DATE	APPROVED

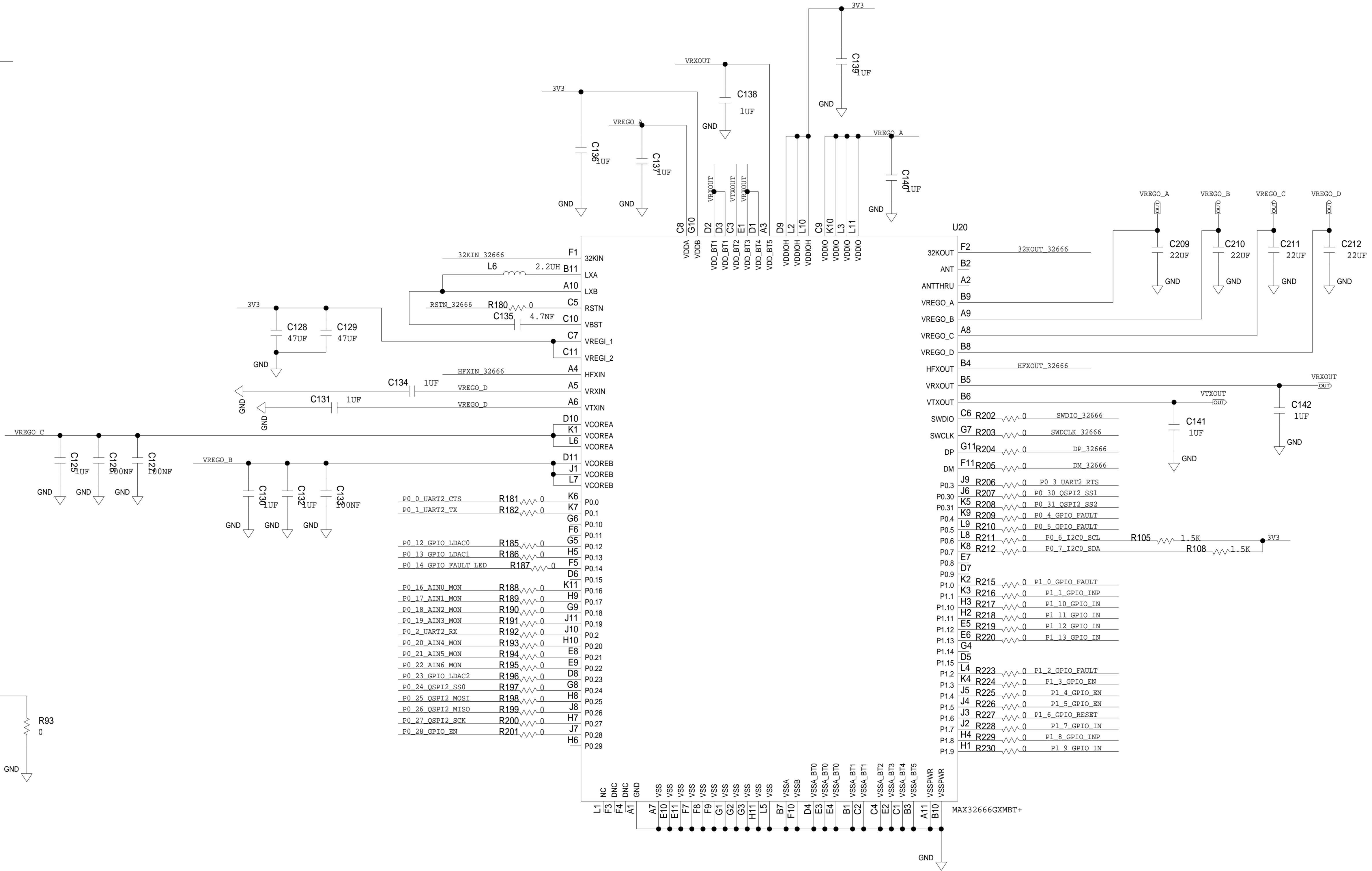
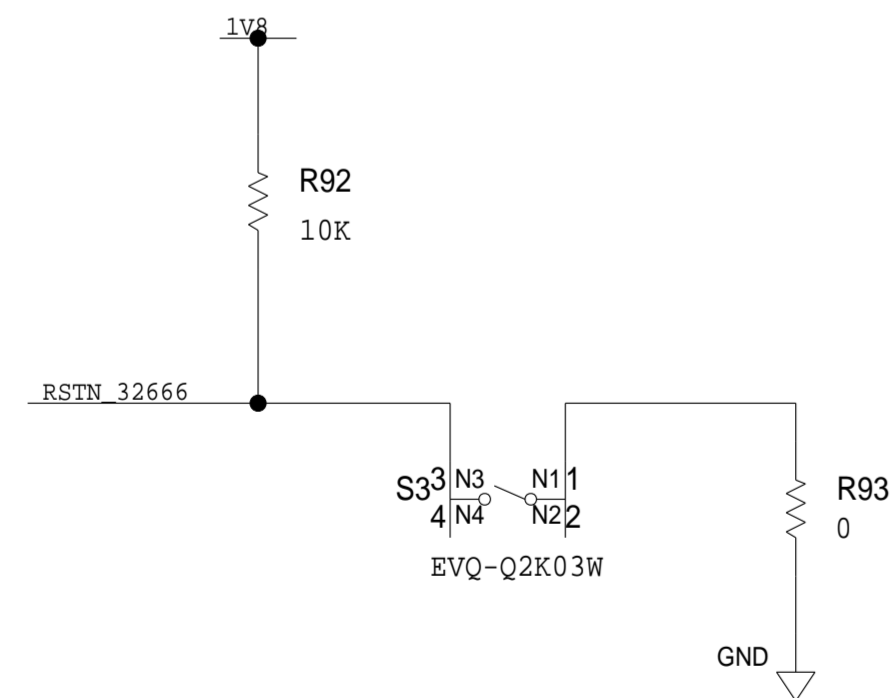
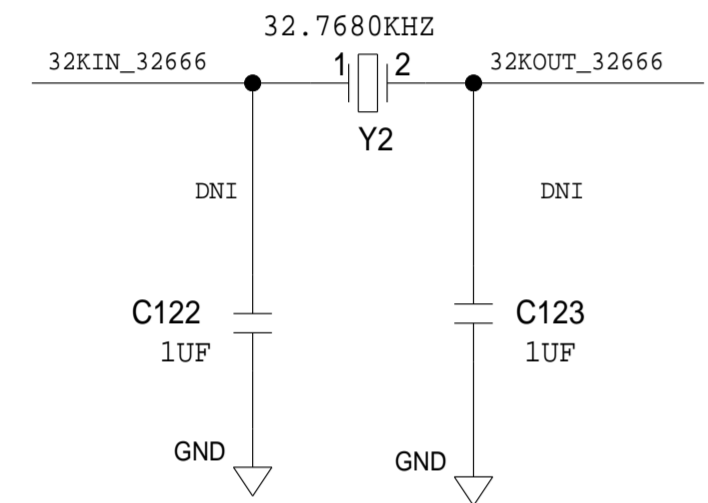
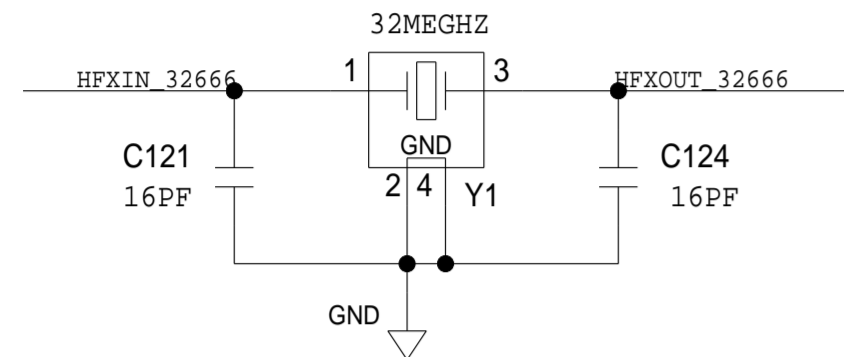

_P0_0_UART2_CTS	R181	0	K6	P0.0
_P0_1_UART2_TX	R182	0	K7	P0.1
			G6	P0.10
			F6	P0.11
_P0_12_GPIO_LDAC0	R185	0	G5	P0.12
_P0_13_GPIO_LDAC1	R186	0	H5	P0.13
_P0_14_GPIO_FAULT_LED	R187	0	F5	P0.14
			D6	P0.15
_P0_16_AIN0_MON	R188	0	K11	P0.16
_P0_17_AIN1_MON	R189	0	H9	P0.17
_P0_18_AIN2_MON	R190	0	G9	P0.18
_P0_19_AIN3_MON	R191	0	J11	P0.19
_P0_2_UART2_RX	R192	0	J10	P0.2
_P0_20_AIN4_MON	R193	0	H10	P0.20
_P0_21_AIN5_MON	R194	0	E8	P0.21
_P0_22_AIN6_MON	R195	0	E9	P0.22
_P0_23_GPIO_LDAC2	R196	0	D8	P0.23
_P0_24_QSPI2_SS0	R197	0	G8	P0.24
_P0_25_QSPI2_MOSI	R198	0	H8	P0.25
_P0_26_QSPI2_MISO	R199	0	J8	P0.26
_P0_27_QSPI2_SCK	R200	0	H7	P0.27
_P0_28_GPIO_EN	R201	0	J7	P0.28
			H6	P0.29

	SCHEMATIC		
	HW TYPE : Customer Evaluation Product(s) : AD3552R, MAX32666 : LTC7000		
DESIGN VIEW <DESIGN_VIEW>	DRAWING NO. 02_079905	REV D	
PTD ENGINEER Z. ARCEO	SIZE D	SCALE 1:1	SHEET 10 OF 14

PINS , CONNECTORS

REVISIONS			
REV	DESCRIPTION	DATE	APPROVED

USB-UART SERIAL CONNECTION

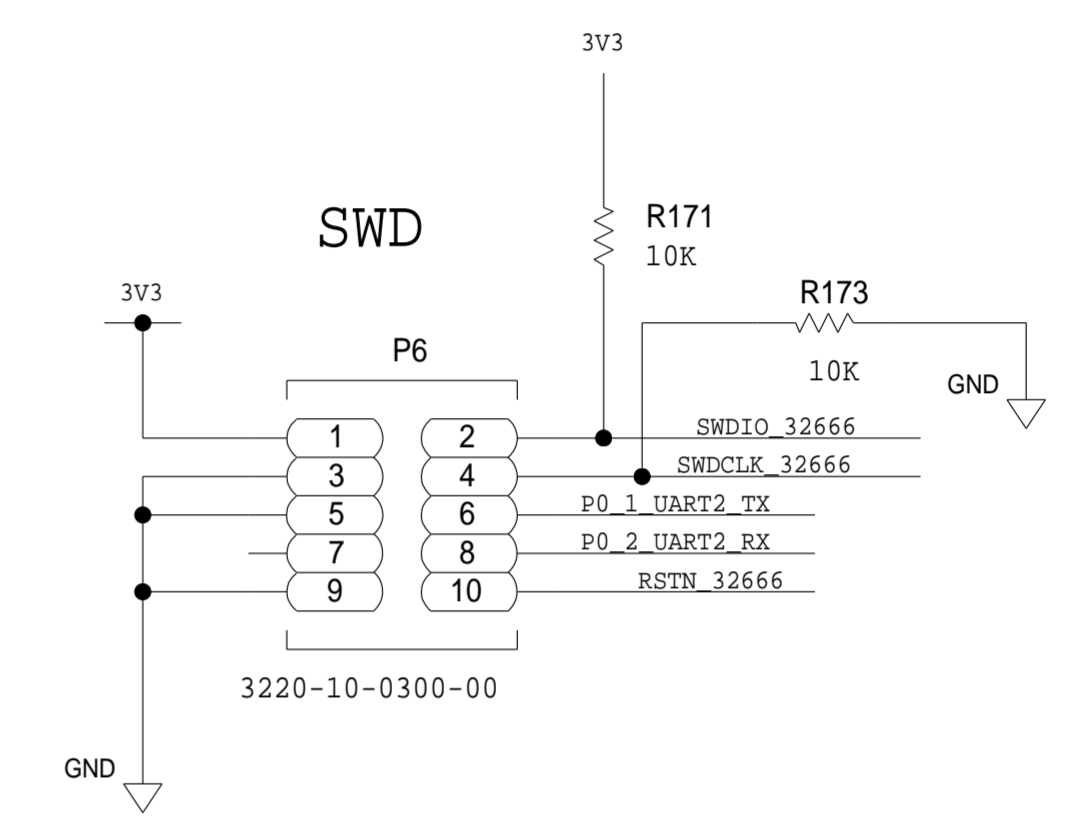
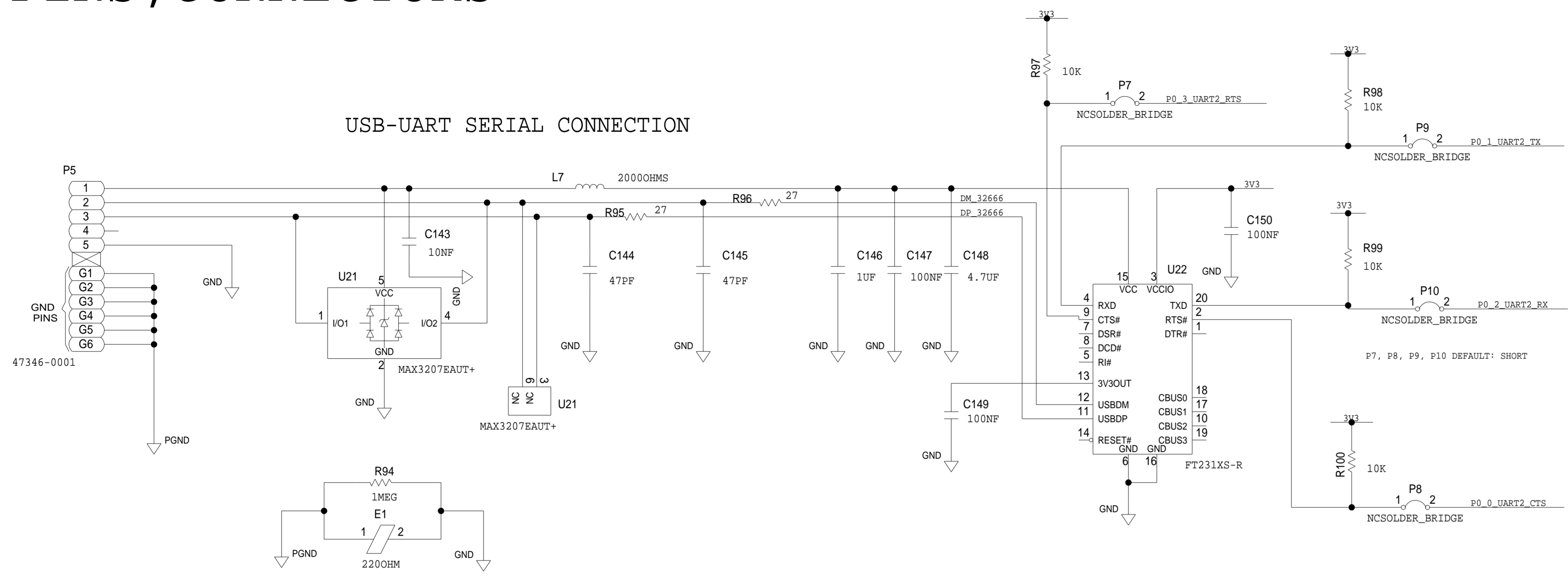

A5M36TG140 GAN AMP

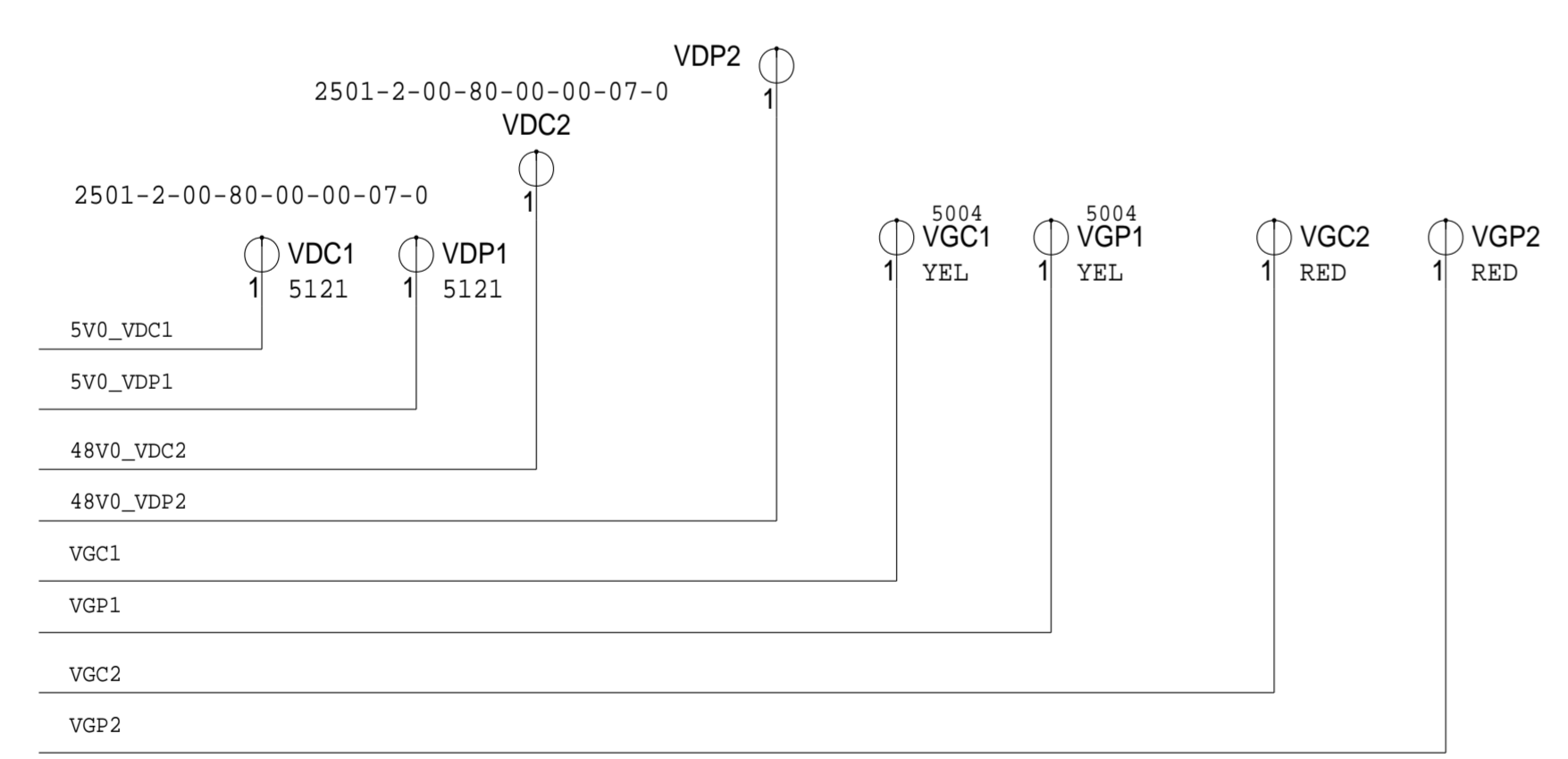

GTRB394608FC-V1 GAN AMP

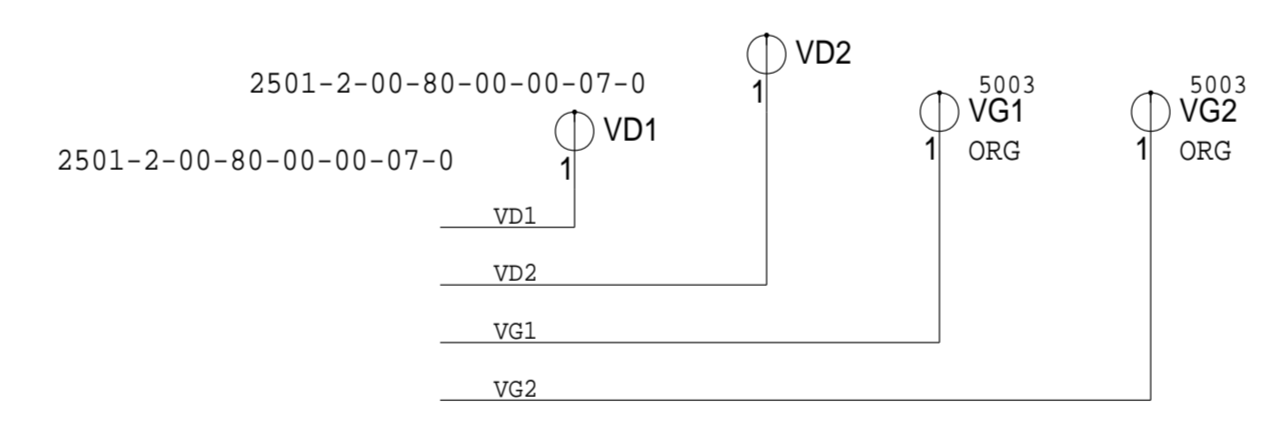

BTS6201U DRIVER AMP

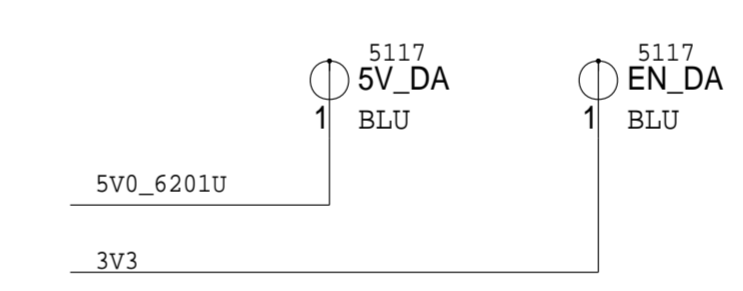

ADL5611 GAIN BLOCK

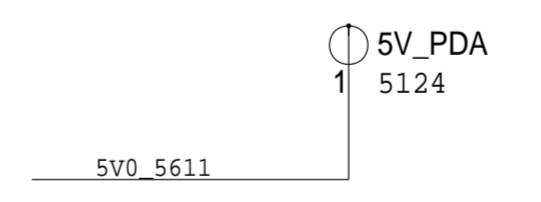

HMC849A RF SWITCH

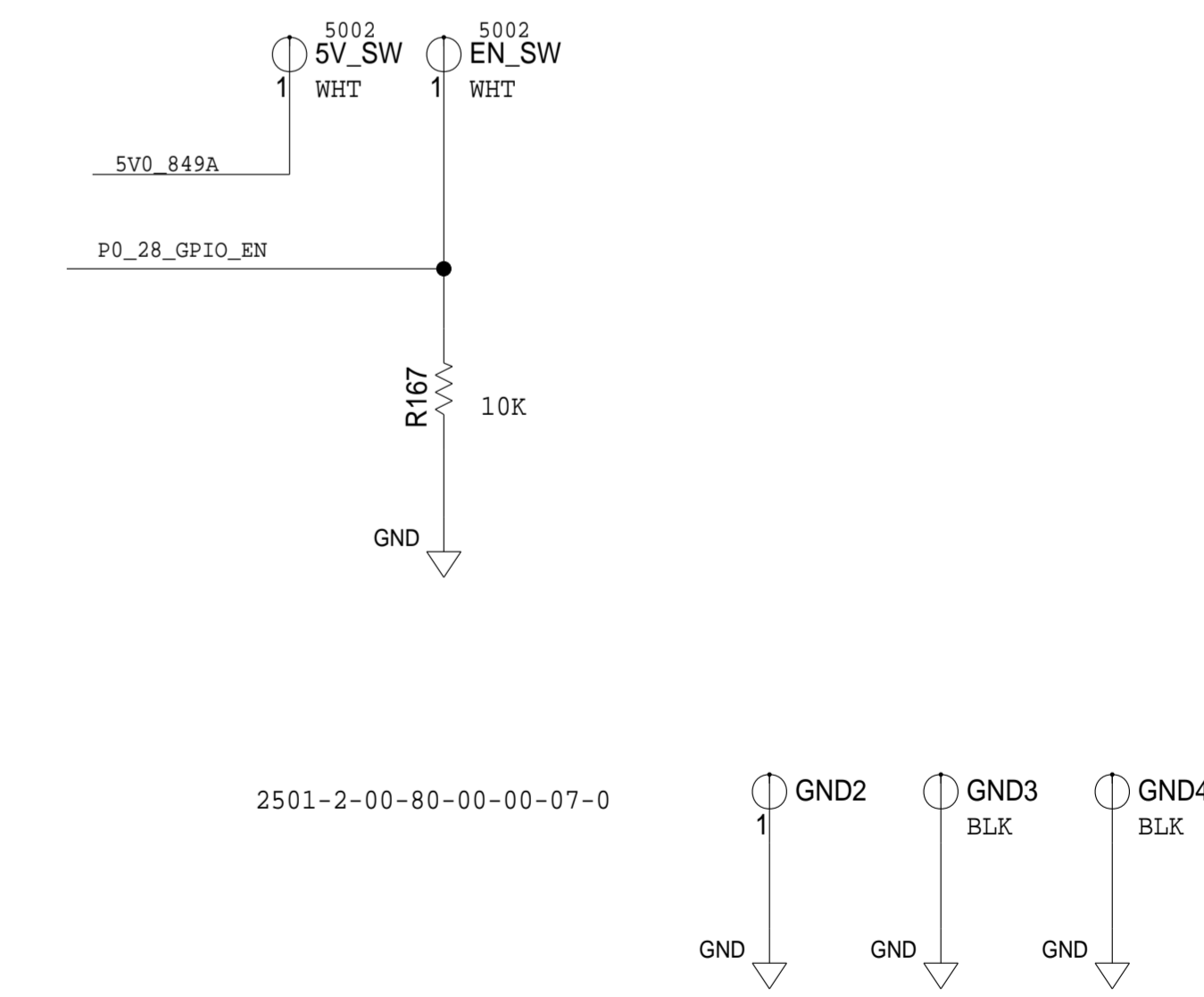

ANALOG DEVICES				SCHEMATIC			
<small>THIS DRAWING IS THE PROPERTY OF ANALOG DEVICES INC. IT IS NOT TO BE REPRODUCED OR COPIED, IN WHOLE OR IN PART, OR USED FOR ANY OTHER PURPOSE DETRIMENTAL TO THE INTERESTS OF ANALOG DEVICES. THE EQUIPMENT SHOWN HEREIN MAY BE PROTECTED BY PATENTS OWNED OR CONTROLLED BY ANALOG DEVICES.</small>				HW TYPE : Customer Evaluation Product(s) : AD3552R, MAX32666 : LTC7000			
				DESIGN VIEW <DESIGN_VIEW>		DRAWING NO. 02_079905	
PTD ENGINEER Z. ARCEO		SIZE D		SCALE 1:1		SHEET 11 OF 14	

REVISIONS			
REV	DESCRIPTION	DATE	APPROVED

LTC2992

DRAIN CURRENT AND VOLTAGE MONITOR LDMOS AND GAN A5M36TG140

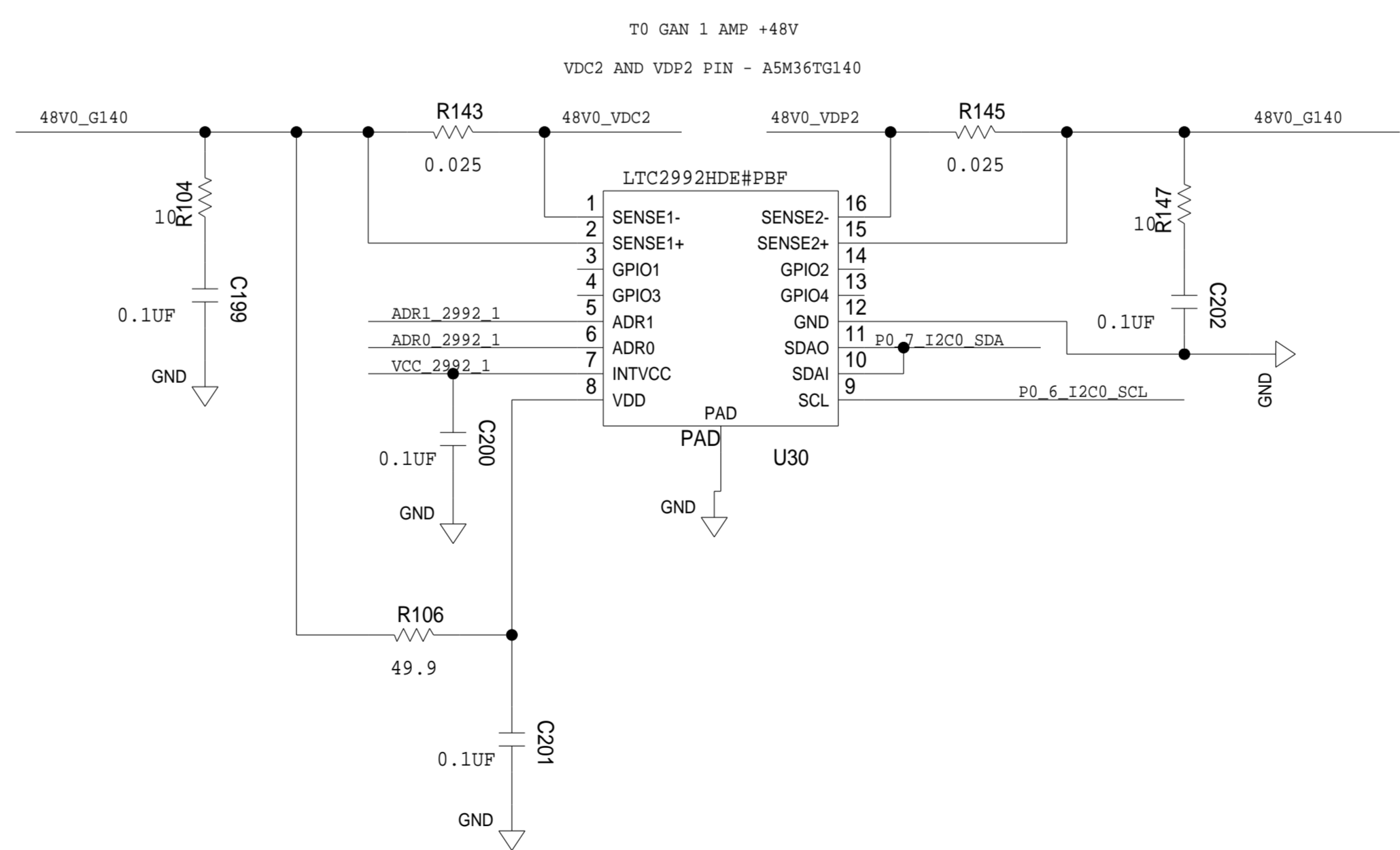
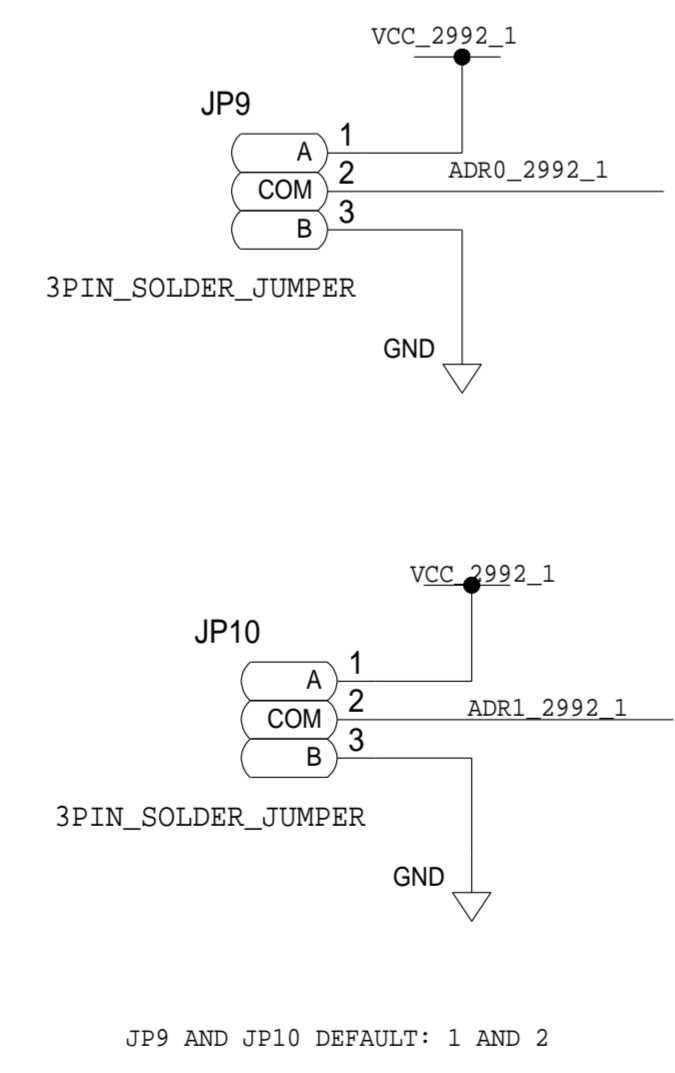
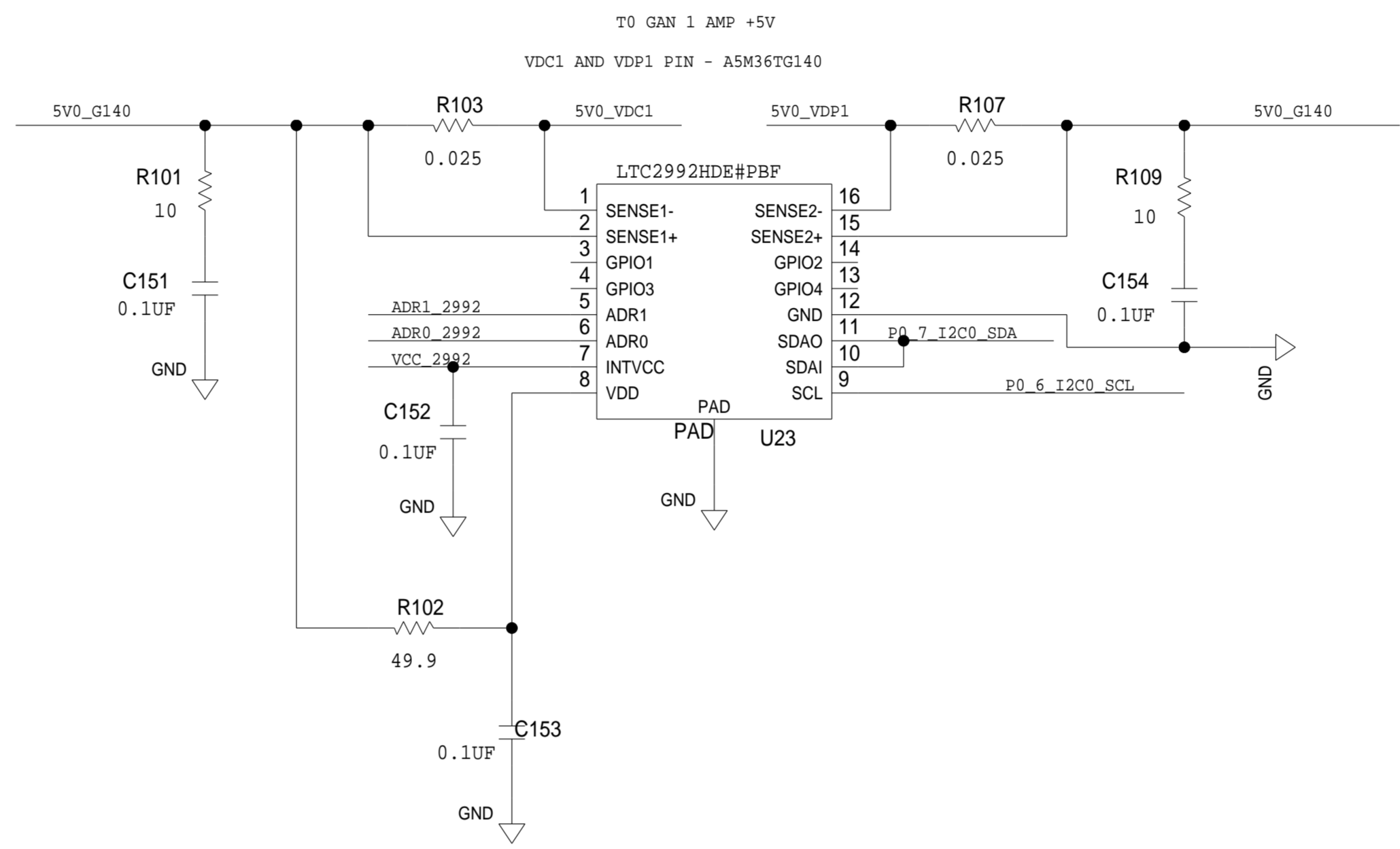
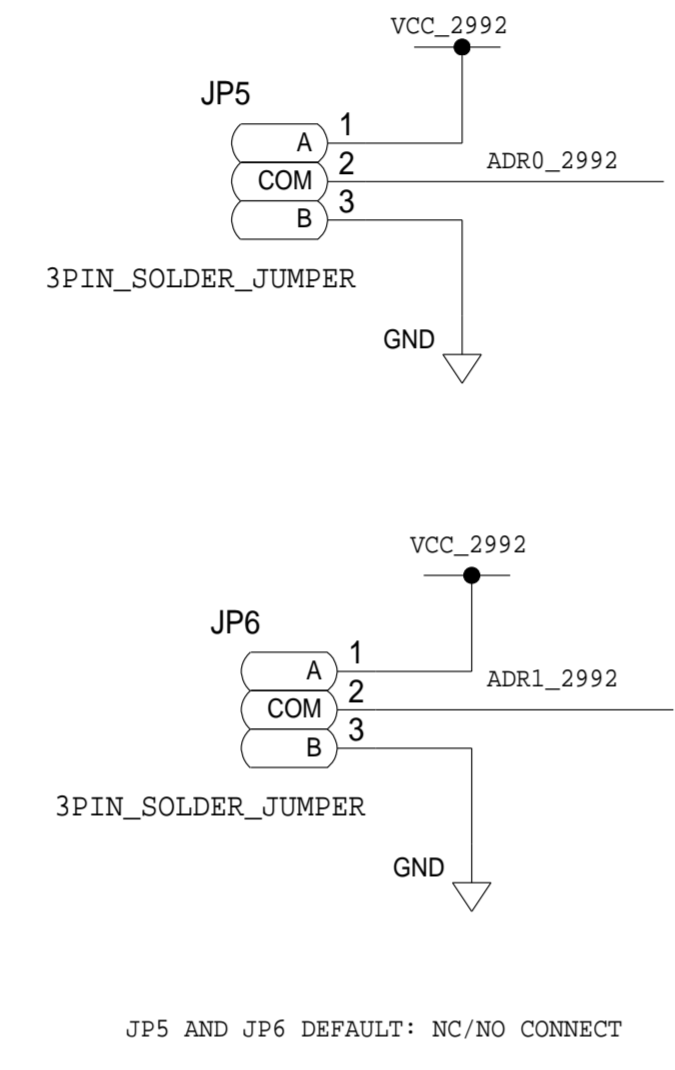

	SCHEMATIC		
	HW TYPE : Customer Evaluation Product(s): Ad3552R, MAX32666 : LTC7000		
DESIGN VIEW <DESIGN_VIEW>	DRAWING NO. 02_079905	REV D	
PTD ENGINEER Z. ARCEO	SIZE D	SCALE 1:1	SHEET 12 OF 14

REVISIONS			
REV	DESCRIPTION	DATE	APPROVED

LTC2992

DRAIN CURRENT AND VOLTAGE MONITOR

GAN GTRB384608FC-V1

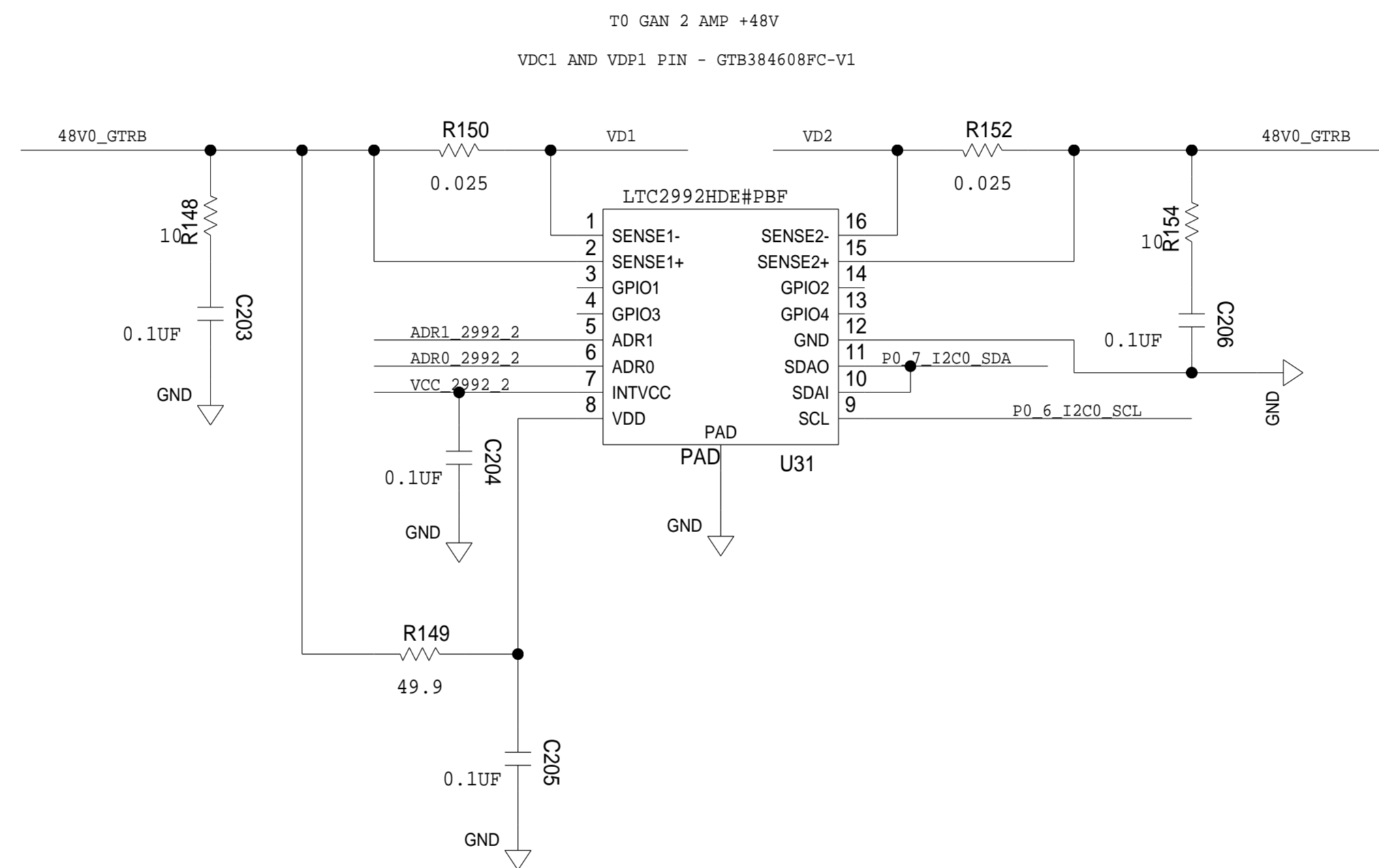
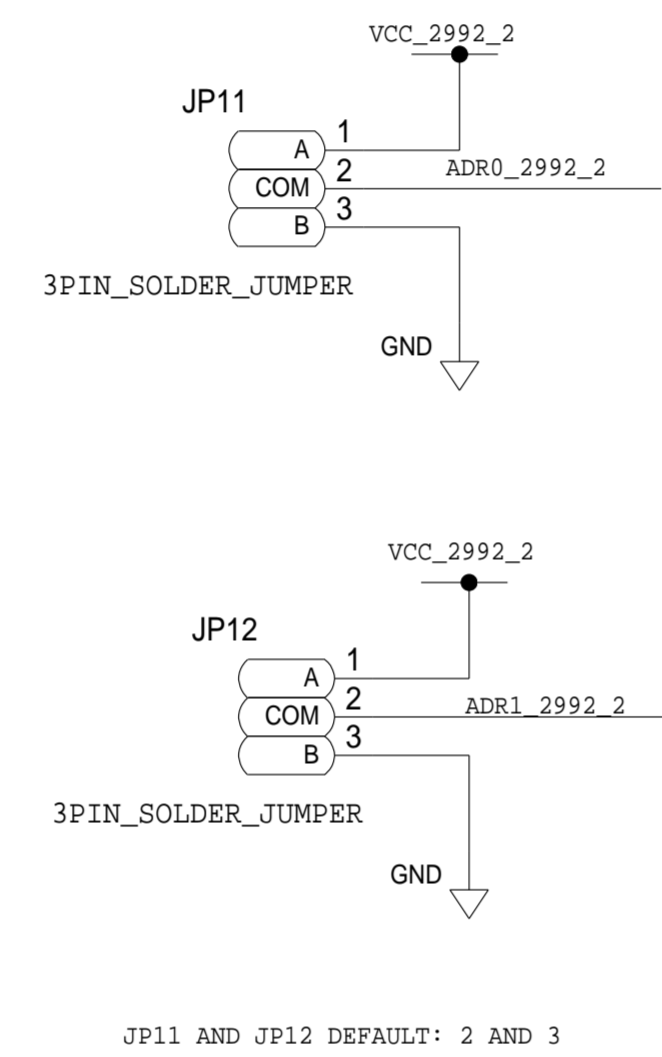

	SCHEMATIC		
	HW TYPE : Customer Evaluation Product(s): AD3552R, MAX32666 : LTC7000		
DESIGN VIEW <DESIGN_VIEW>	DRAWING NO. 02_079905	REV D	
PTD ENGINEER Z. ARCEO	SIZE D	SCALE 1:1	SHEET 13 OF 14

MAX6516

TEMPERATURE SENSOR

REVISIONS			
REV	DESCRIPTION	DATE	APPROVED

Temperature Range (°C)	Output Voltage (V)	ADC Input (V)
-45	2.6	1.1581
0	2.12	0.9443
+125	0.81	0.3608

ADC REF: 1.22V INTERNAL

DEFAULT HYSTERESIS: 10 DEGREES

HYSTERESIS SETTINGS

2 DEGREES OF HYSTERESIS:

R144: CONNECT TO VCC. POPULATE WITH 0 OHM RESISTOR

R146: UNPOPULATE/NO CONNECT

10 DEGREES OF HYSTERESIS:

R144: UNPOPULATE/NO CONNECT

R146: CONNECT TO GND. POPULATE WITH 0 OHM RESISTOR

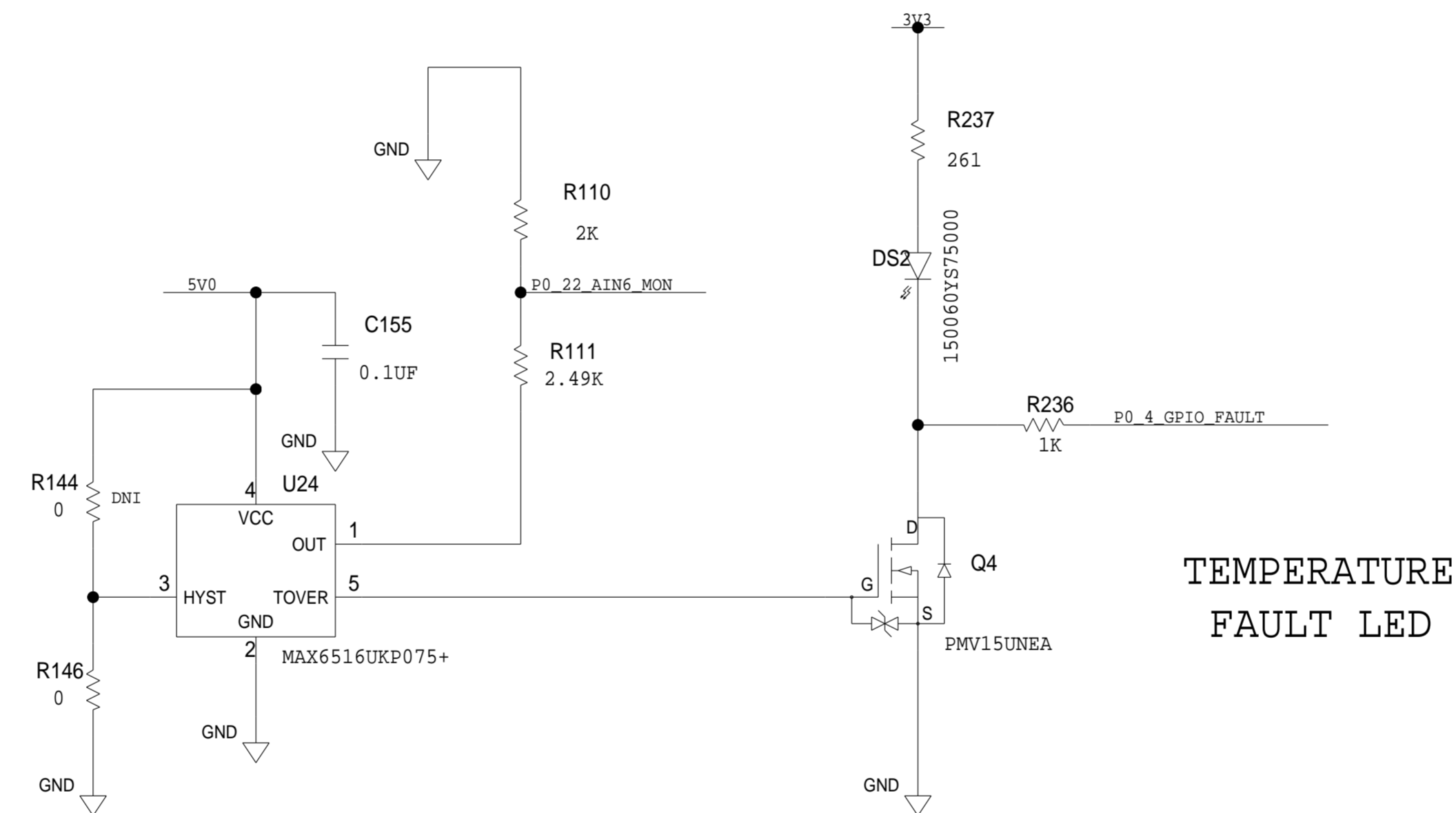

TEMPERATURE
FAULT LED

	SCHEMATIC		
	HW TYPE : Customer Evaluation Product(s): AD3552R, MAX32666 : LTC7000		
DESIGN VIEW <DESIGN_VIEW>	DRAWING NO. 02_079905	REV D	
PTD ENGINEER Z. ARCEO	SIZE D	SCALE 1:1	SHEET 14 OF 14