

REVISIONS			
REV	DESCRIPTION	DATE	APPROVED
A	INITIAL RELEASE	11APR18	J.HAN
B	AS PER ECR-078181	31AUG18	J.HAN
C	AS PER ECR-083981	22JAN19	J.HAN

SPECIFICATIONS:

ROHS COMPLIANCE NOTE: HOMOGENOUS MATERIALS IN THIS BOARD SHALL BE COMPLIANT THE EU RoHS DIRECTIVE 2002/95/EC

MATERIALS; ALL LAMINATES AND BONDING MATERIALS SHOULD BE SELECTED FROM IPC-4101 OR IPC-4103, MINIMUM Tg>170degC, Td>300degC, U.L. RATING OF 94 V-0

MATERIAL FAMILY; ISOLA 370HR

CLADDING; EXTERNAL LAYERS .5 OZ. COPPER, OVERPLATE TO 1.5 OZ. INTERNAL SIGNAL LAYERS .5 OZ. COPPER. INTERNAL PLANE LAYERS 1 OZ. COPPER.

NOTE: IF THE LAYER STACKUP CONFLICTS WITH THE ABOVE CLADDING SPECIFICATIONS THEN THE LAYER STACKUP SHALL TAKE PRECEDENCE.

SOLDER MASK; SHALL BE LIQUID PHOTOIMAGEABLE (LPI) APPLIED ON BOTH SIDES OVER BARE COPPER OR GOLD AND SHALL MEET IPC-SM-840 (LATEST REV.) CLASS 3. COLOR GREEN.

SILK SCREEN; SHALL BE PERMANENT NON-CONDUCTIVE EPOXY INK, COLOR: WHITE SYNTHETIC INKJET PRINTING ALLOWED FOR DENSE BOARDS, COLOR: WHITE

SURFACE FINISH; ENIG (ELECTROLESS NICKEL/IMMERSION GOLD) PER IPC-4552 LATEST REVISION

INTENTIONAL SHORTS; IF SUPPLIED DATA INCLUDES A FILE "READ\_ME.2", THEN INTENTIONAL NET SHORTS EXIST. CUSTOMER REVIEW AND APPROVAL IS REQUIRED IF SUPPLIED DATA REPORTS ANY CONDITION THAT DOES NOT MATCH "READ\_ME.2" FILE PROVIDED.

TEST REQUIREMENTS; 100% NETLIST ELECTRICAL VERIFICATION USING CUSTOMER SUPPLIED IPC-D-356 NETLIST FOR OPENS AND SHORTS WHEN "GERBER DATA" IS PROVIDED. THIS VERIFICATION ALSO REQUIRED FOR "ODB+" DATA PER EMBEDDED NETLIST.

REQUIREMENTS:

- REFER TO IPC-6010 SERIES (LATEST REV.), CLASS 2 FOR FABRICATION UNLESS OTHERWISE SPECIFIED.
- ACCEPTABILITY PER ANALOG DEVICES, INC. SPECIFICATION TST00115, (LATEST REVISION.)
- MODIFICATIONS TO THE ARTWORK ARE NOT ALLOWED WITHOUT WRITTEN AUTHORIZATION.
- HOLE PATTERN TOLERANCES FOR UNDIMENSIONED HOLES SHALL BE A DIAMETER OF 0.005 INCHES FROM THEIR TRUE POSITION.
- PLATED HOLE WALL THICKNESS SHALL NOT BE LESS THAN 0.001 INCH MINIMUM AVERAGE, WITH NO READING LESS THAN .0008 BY CROSS SECTION.
- HOLE DIAMETERS APPLY AFTER PLATING.
- FINISHED CONDUCTOR WIDTHS SHALL NOT BE REDUCED FROM THE NOMINAL INDICATED ON THE MASTER PATTERN, BY MORE THAN THE CONDUCTOR THICKNESS.
- MINIMUM DESIGN LINE WIDTH IS .0066 INCH.
- MINIMUM DESIGN SPACING IS .0075 INCH.
- ~~NON-FUNCTIONAL PAD REMOVAL FROM INNER SIGNAL LAYERS MAY BE PERFORMED AFTER CUSTOMER APPROVAL.~~
- IF PAD SIZES PROVIDED ARE NOT LARGE ENOUGH TO MAINTAIN ANNULAR RING REQUIREMENT, MFR. MAY REQUEST APPROVAL TO TEAR DROP PADS TO MAINTAIN ANNULAR RING. (AT PAD TO TRACE INTERSECTION ONLY AND ELECTRICAL INTEGRITY MUST BE MAINTAINED.)
- THIEVING MAY BE ADDED TO COMPENSATE FOR LOW COPPER DENSITY AREAS ON THIS DESIGN ONLY AFTER REVIEW AND APPROVAL FROM THE CUSTOMER:
  - A. THIEVING TO CARD EDGE, FIDUCIALS, NON-PLATED THROUGH HOLES, ALL OTHER FEATURES TO BE 0.200 INCH MINIMUM.
  - B. THERE SHALL BE NO THIEVING IN ANY AREAS FREE OF SOLDER MASK OR INTERNAL COPPER PLANES.
- MFR. TO LEGIBLY ETCH OR STAMP/SCREEN WITH PERMANENT NON-CONDUCTIVE INK ON SECONDARY SIDE IN A CLEAR AREA UNLESS OTHERWISE INDICATED;
  - A. U.L. CODE-FLAMMABILITY RATING
  - B. DATE CODE (STAMP).
  - C. LOT NUMBER
  - D. MFR LOGO
  - E. SUCCESSFUL ELECTRICAL TEST.
- REPAIRS PER IPC-7711/21 (LATEST REV.) ARE ALLOWED.

4 LAYER STACKUP

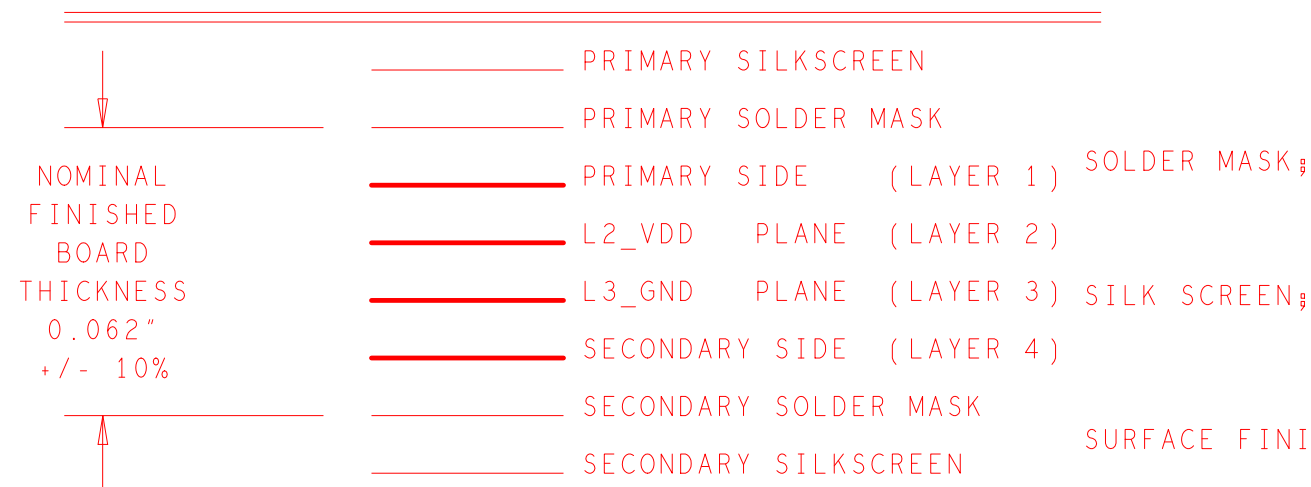

HOLE TOLERANCE  
UNLESS SPECIFIED  
PLATED: +/- 3 MILS  
NON PLATED: +/- 2 MILS

FINISHED HOLES IN MILS				
ALL UNITS ARE IN MILS				
FIGURE	SIZE	PLATED	QTY	TOLERANCE/NOTES
+	10.0	PLATED	700	DIA MAX
□	39.4	PLATED	28	
◇	43.3	PLATED	1	
◦	43.3	PLATED	2	
○	63.0	PLATED	3	
◇	65.0	PLATED	18	
△	160.0	PLATED	4	
A	27.6	NON-PLATED	1	
B	43.3	NON-PLATED	1	
C	160.0	NON-PLATED	2	

CUSTOMER EVALUATION Z

UNLESS OTHERWISE SPECIFIED DIMENSIONS ARE IN INCHES TOLERANCES DECIMALS .XX -- .010 .XXX -- .005 .XXXX -- .0050 FRACTIONS -- 1/32 ANGLES -- 2	APPROVAL	DATE	WWM DIVISION 804 WOBURN STREET WILMINGTON, MA 01887			
	TEMPLATE ENGINEER N/A	N/A				
MATERIAL	HARDWARE SERVICES R. MACDONALD	11APR18	TITLE <b>FABRICATION</b> <b>ADE1201 8-CHANNEL</b> <b>EVAL BOARD Z</b>			
	HARDWARE SYSTEMS N/A	N/A				
	TEST ENGINEER N/A	N/A				
FINISH	COMPONENT ENGINEER A. CAUILAN-AGENA	11APR18	SIZE	FSCM NO	DRAWING NUMBER	
	TEST PROCESS N/A	N/A	C	24355	09-048916	
	HARDWARE RELEASE K. JABATAN	11APR18				REV
	DESIGNER N. CORDOVA	11APR18				C
PTD ENGINEER J. HAN	11APR18					
CHECKER N/A	N/A					
DO NOT SCALE DWG		SCALE	1/1	SHEET	1 OF 1	

REVISIONS			
REV	DESCRIPTION	DATE	APPROVED
A	INITIAL RELEASE	11APR18	J.HAN
B	AS PER ECR-078181	31AUG18	J.HAN
C	AS PER ECR-083981	22JAN19	J.HAN

ASSEMBLY NOTES:

1. BOARD ACCEPTABILITY PER ANALOG DEVICES, INC. SPECIFICATION TST00119 (LATEST REVISION).
2. REPAIRS PER IPC-7711/21(LATEST REVISION) ARE ALLOWED.
3. RoHS COMPLIANCE: ASSEMBLY VENDOR SHOULD ASSURE COMPLIANCE WITH LEAD-FREE AND RoHS PCB ASSEMBLY STANDARDS (EU RoHS DIRECTIVE 2002/95/EC).

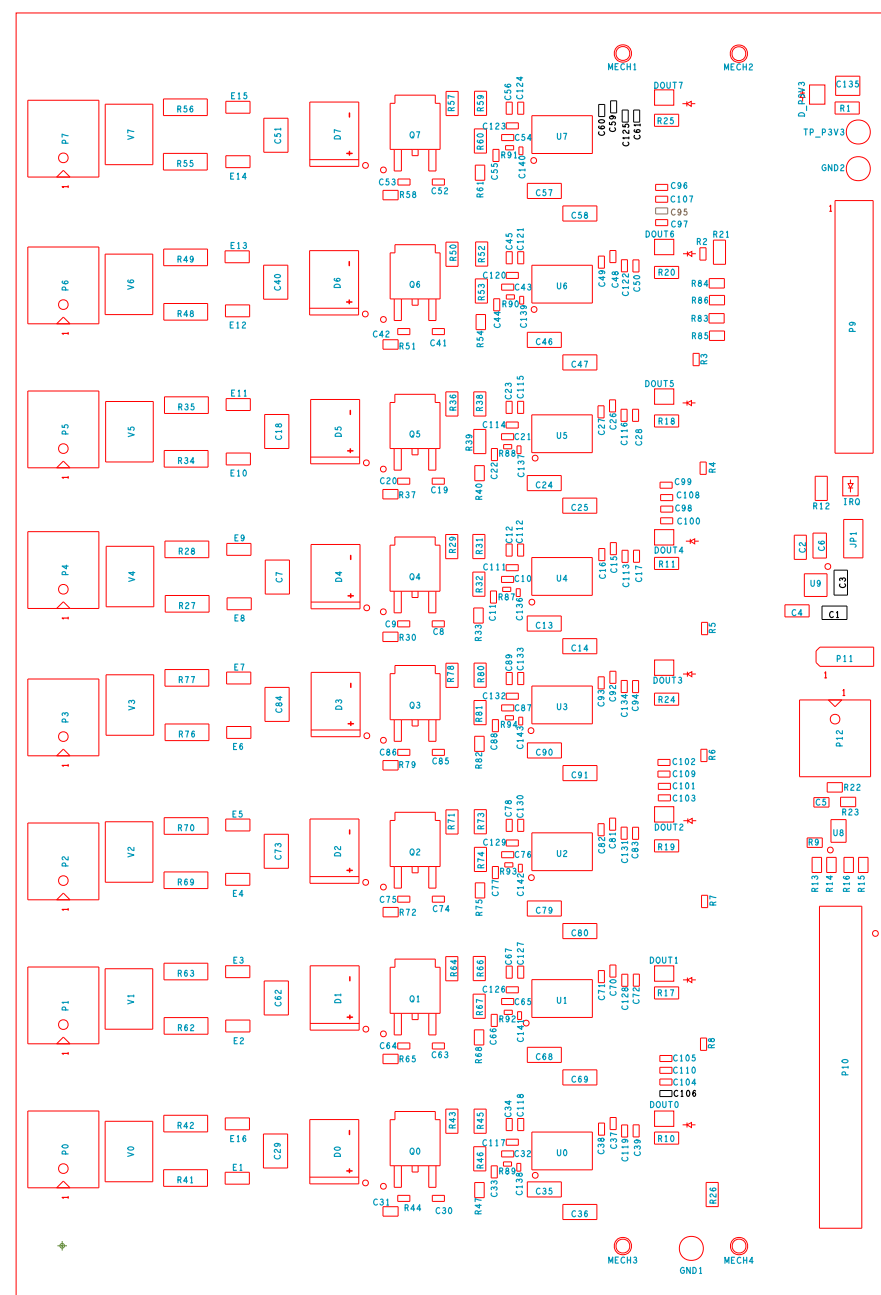

CUSTOMER EVALUATION Z

UNLESS OTHERWISE SPECIFIED DIMENSIONS ARE IN INCHES TOLERANCES DECIMALS FRACTIONS ANGLES .XX -.010 --1/32 -- 2 .XXX -.005 .XXXX -.0050	APPROVAL TEMPLATE ENGINEER N/A	DATE N/A	 WWM DIVISION 804 WOBURN STREET WILMINGTON, MA 01887			
	HARDWARE SERVICES R. MACDONALD	11APR18				
MATERIAL	HARDWARE SYSTEMS N/A	N/A	TITLE ASSEMBLY ADE1201 8-CHANNEL EVAL BOARD Z			
	TEST ENGINEER N/A	N/A				
	COMPONENT ENGINEER A. CAUILAN-AGENA	11APR18				
	TEST PROCESS N/A	N/A				
FINISH	HARDWARE RELEASE K. JABATAN	11APR18	SIZE C	FSCM NO 24355	DRAWING NUMBER 01-048916	REV C
	DESIGNER N. CORDOVA	11APR18				
	PTD ENGINEER J. HAN CHECKER N/A	11APR18				
DO NOT SCALE DWG		SCALE 1/1	SHEET 1 OF 1			

L1 PRIMARY  
08-048916-01  
REV C

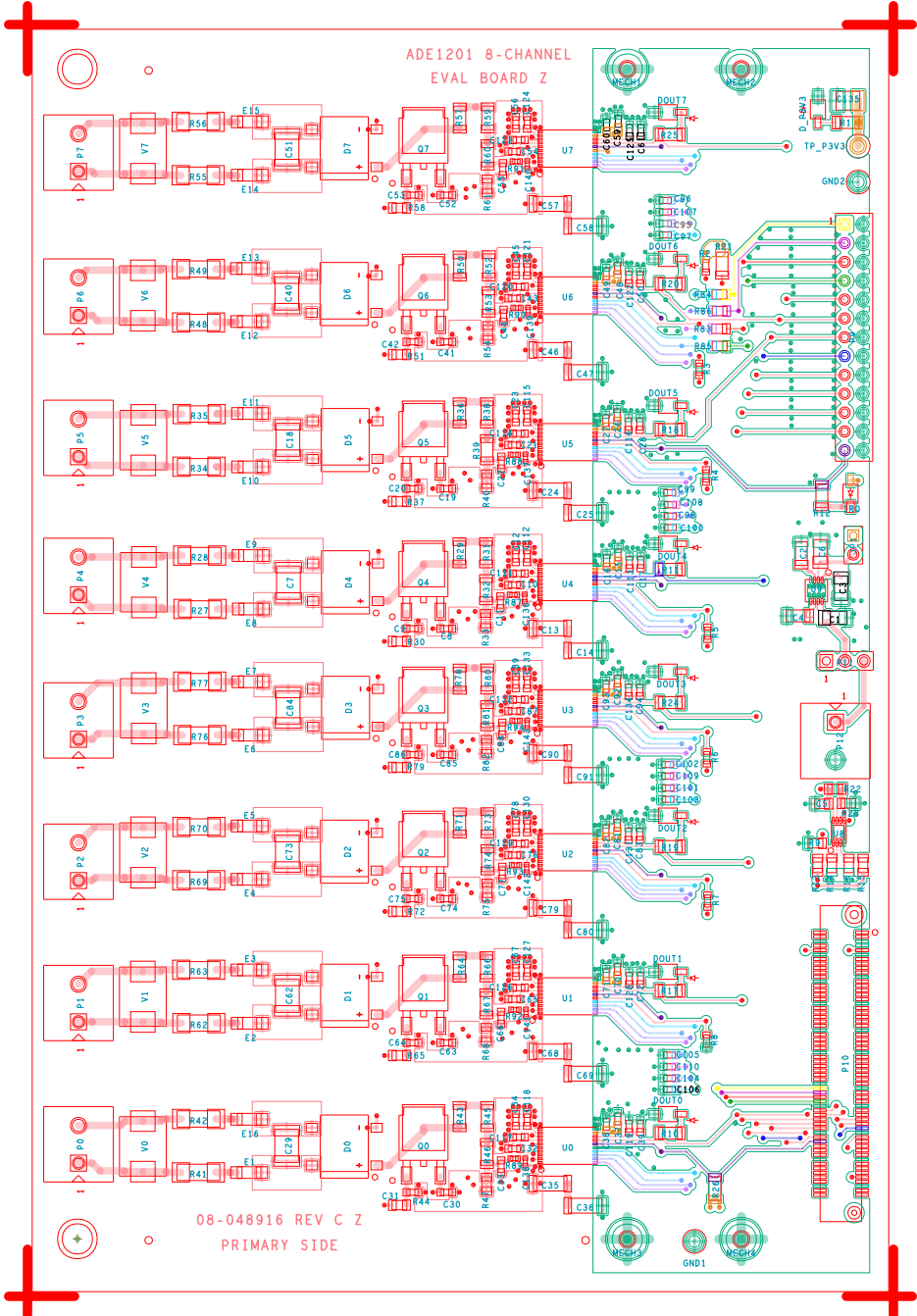

L2 VDD  
08-048916-07  
REV C

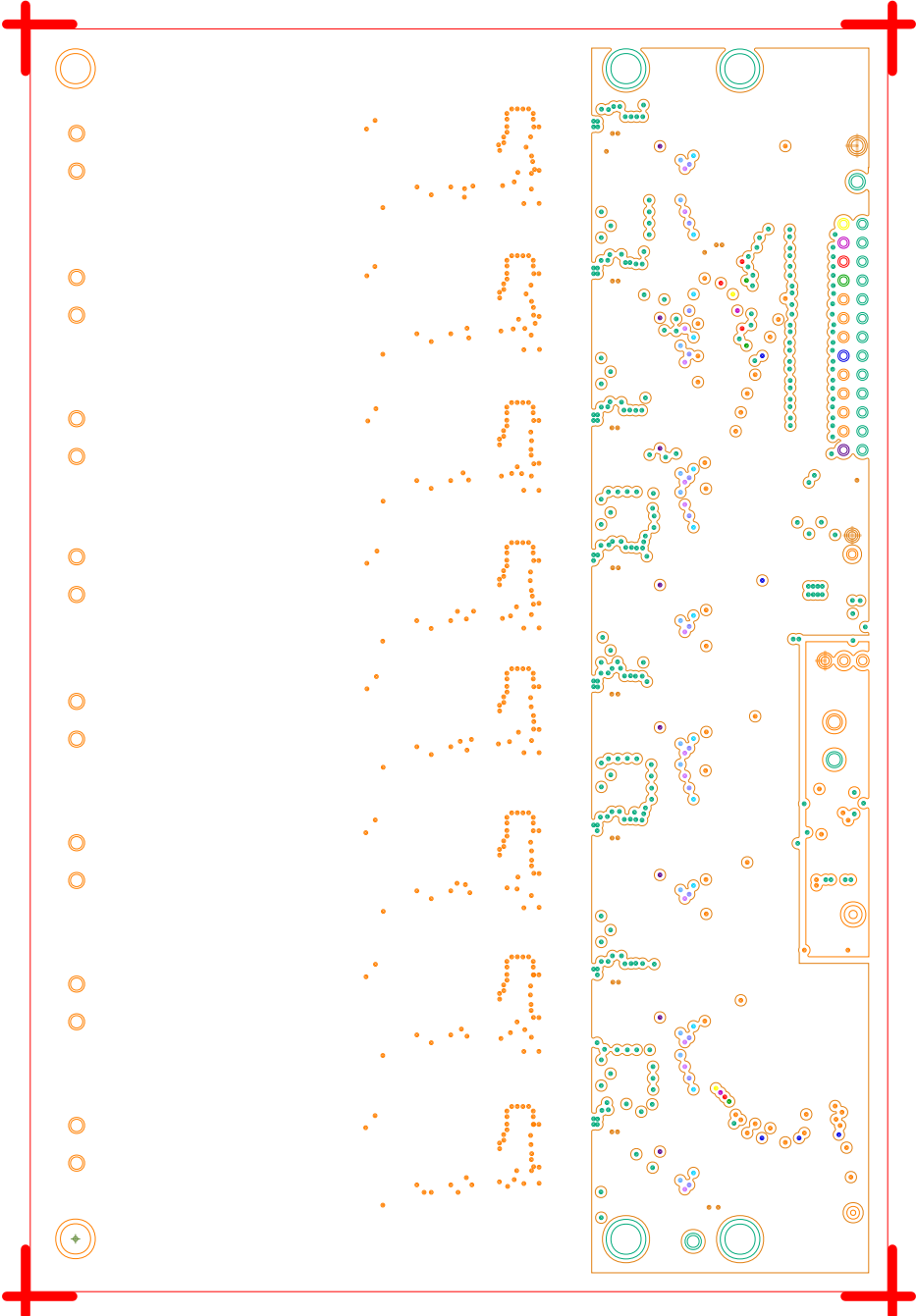

L3 GND  
08-048916-08  
REV C

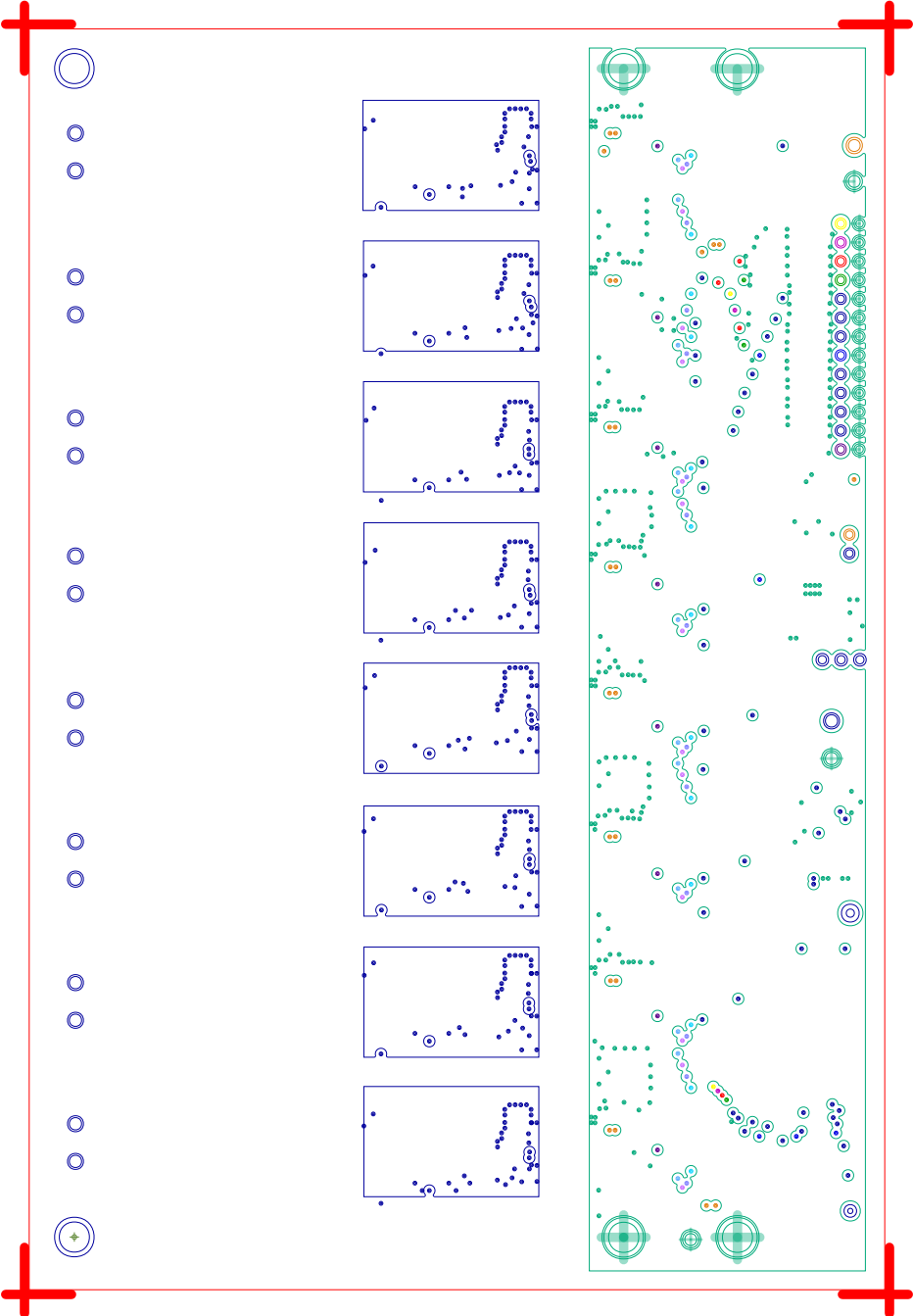

L4 SECONDARY  
08-048916-02  
REV C

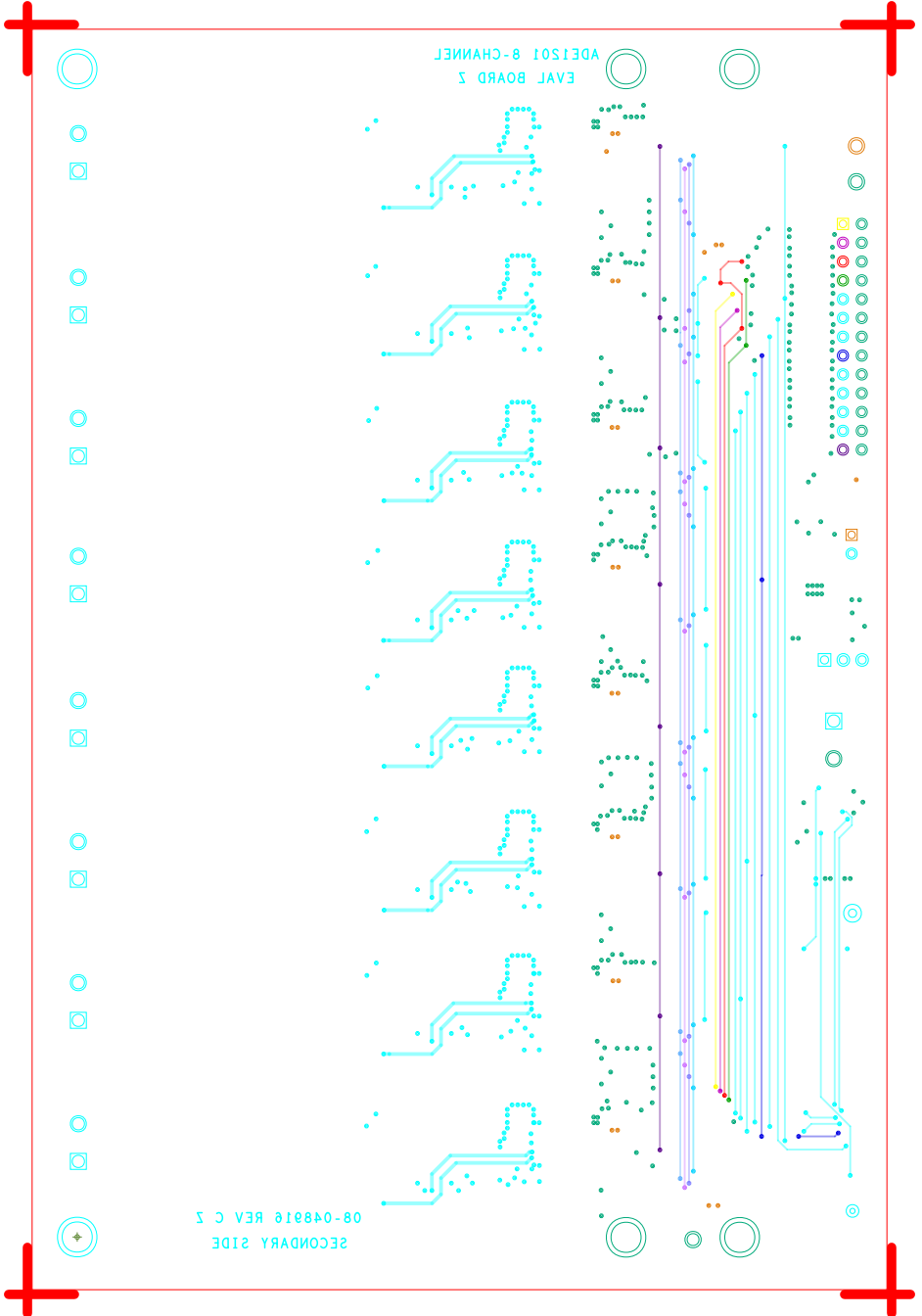

# SILKSCREEN PRIMARY

08-048916-03

REV C

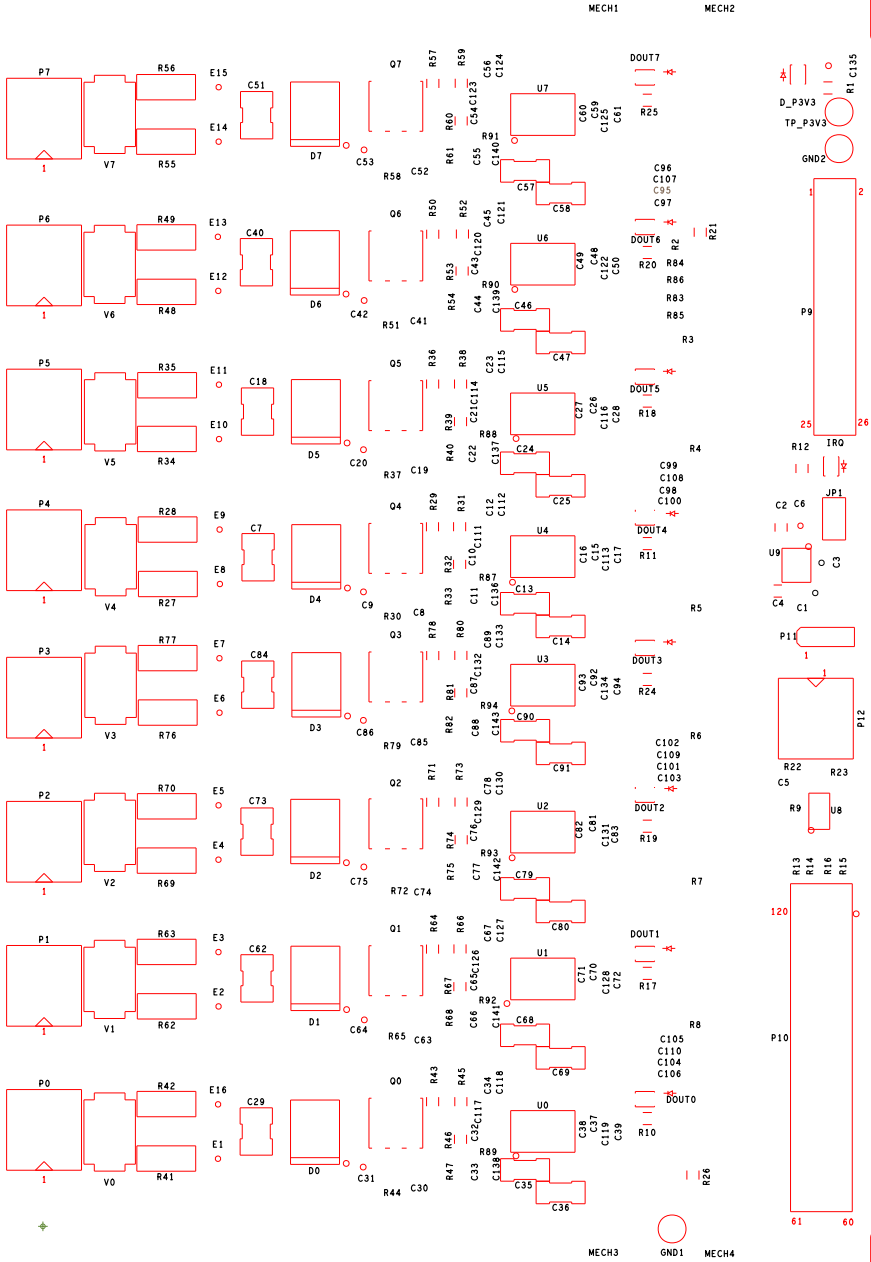

SOLDERMASK PRIMARY

08-048916-04

REV C

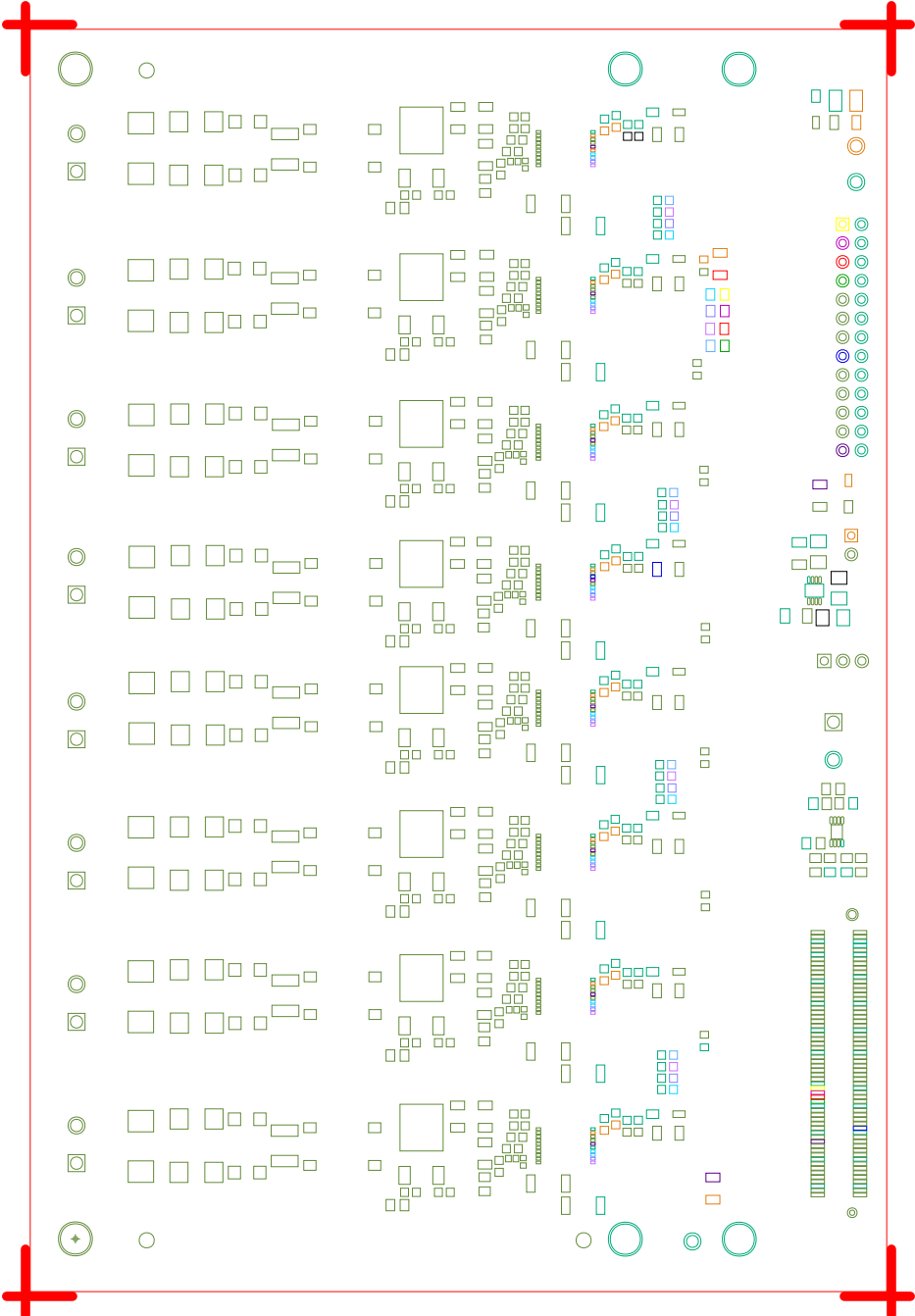



SILKSCREEN SECONDARY  
08-048916-05  
REV C



S  
P1  
I

EVER\_P1  
SND5  
I S

S  
P6  
I

P6

S  
P2  
I

S5 S5

S  
P4  
I

P4

S  
P3  
I

P11  
I

I  
S11  
S

S  
P5  
I

S  
P1  
I

S  
P0  
I



GND1



SOLDERMASK SECONDARY

08-048916-06

REV C

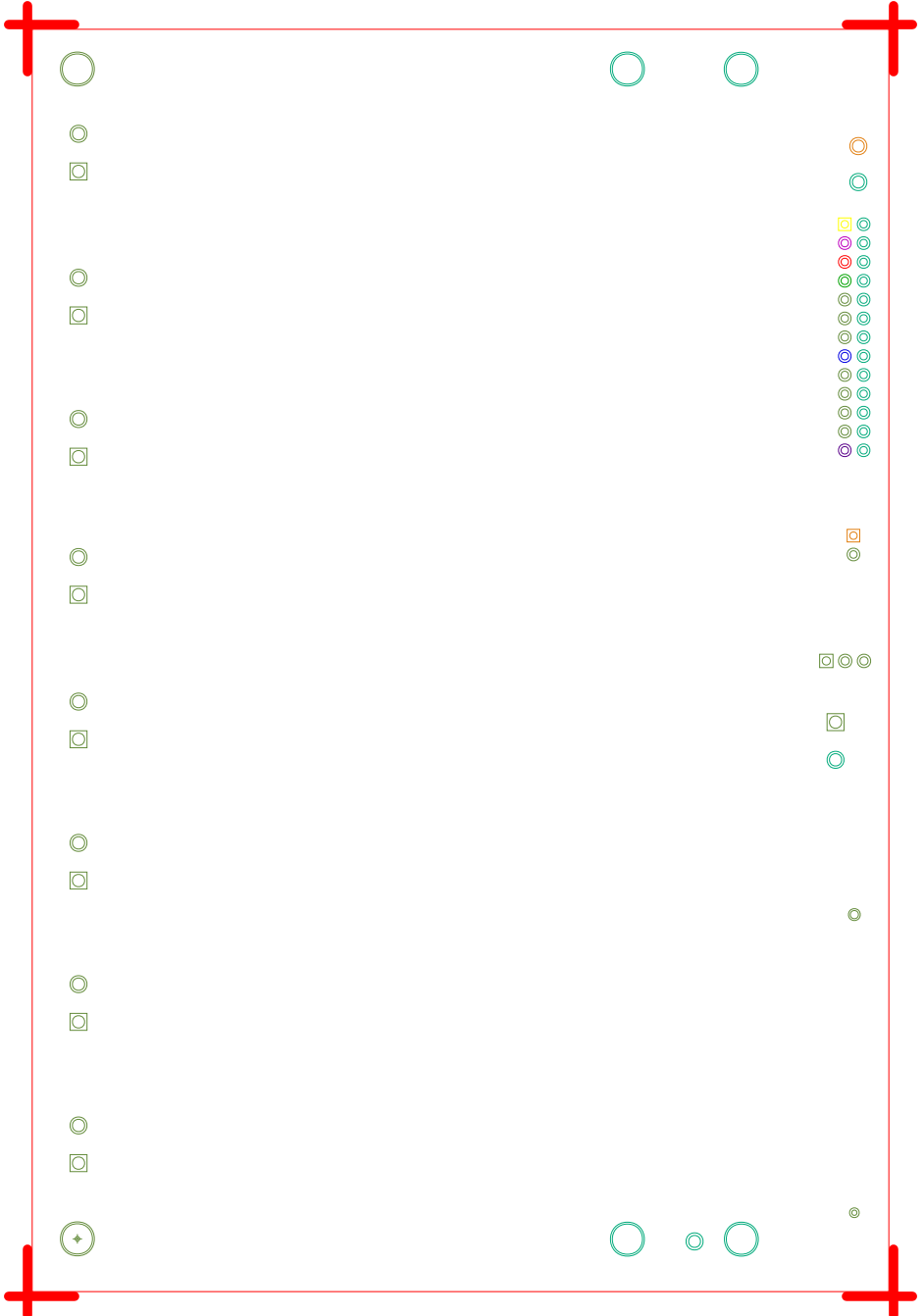

PASTEMASK PRIMARY  
08-048916-09  
REV C

