

REVISIONS			
REV	DESCRIPTION	DATE	APPROVED

USB CONNECTOR

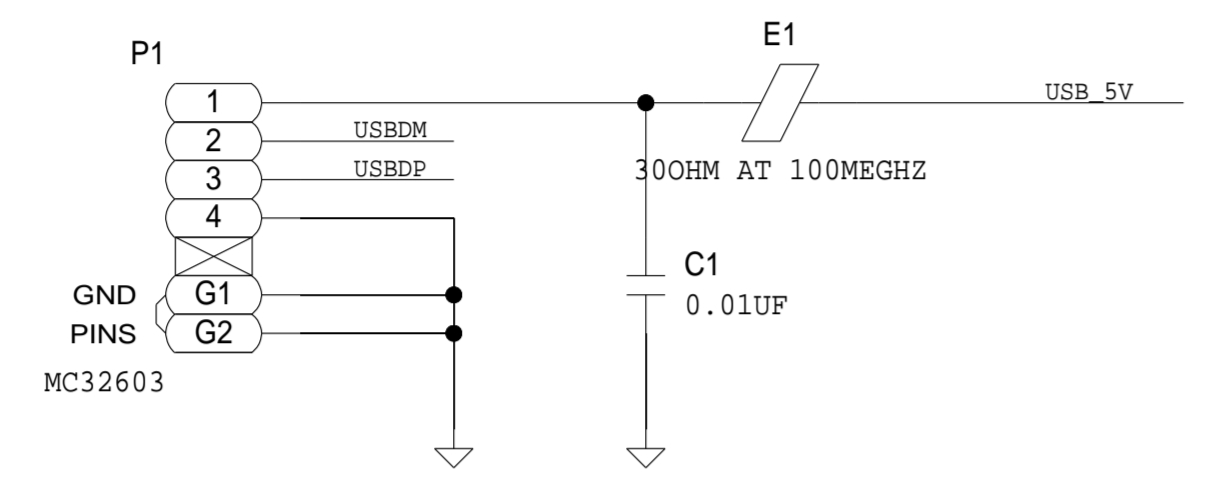

THIS NEEDS TO BE INSERTED FOR THE MOTE FARM VERSION

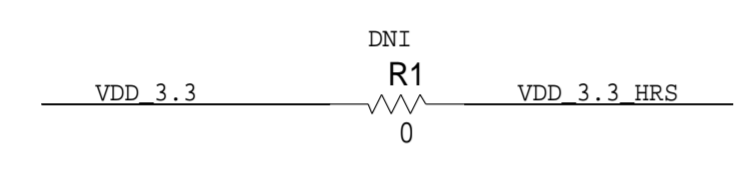

HIROSE CONNECTOR - ONLY FOR FUTURE PROTOTYPING

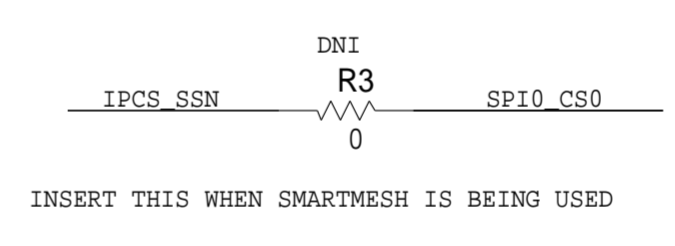
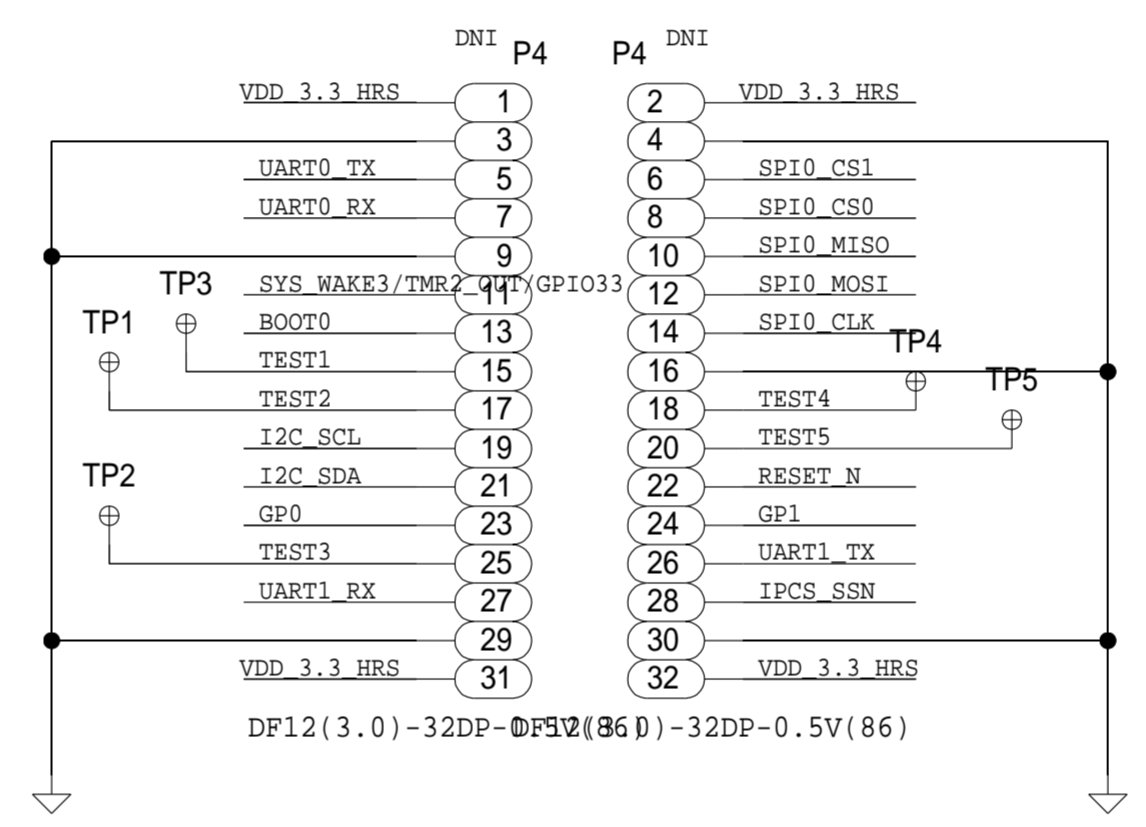

CASTELLATIONS - TO BE SOLDERED ON TO THE BOARD

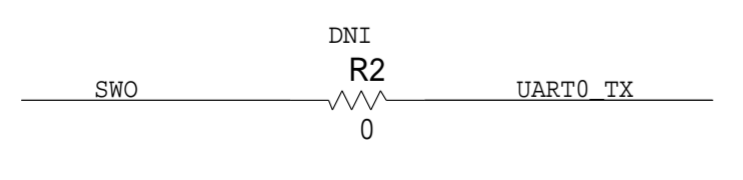
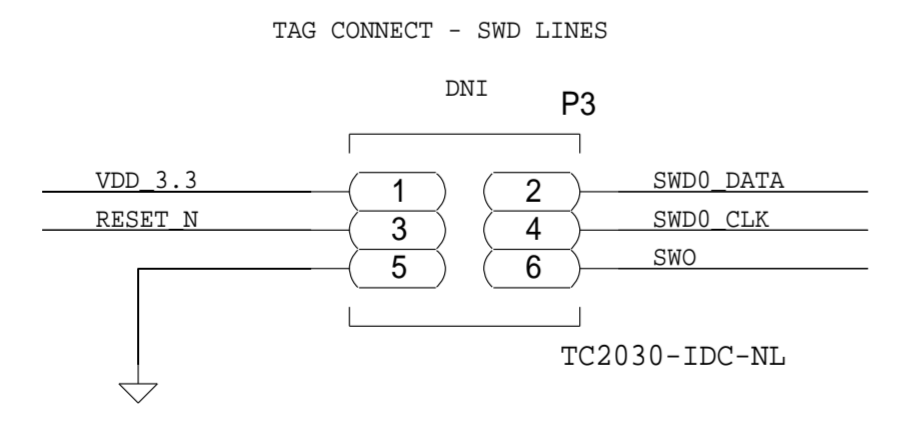
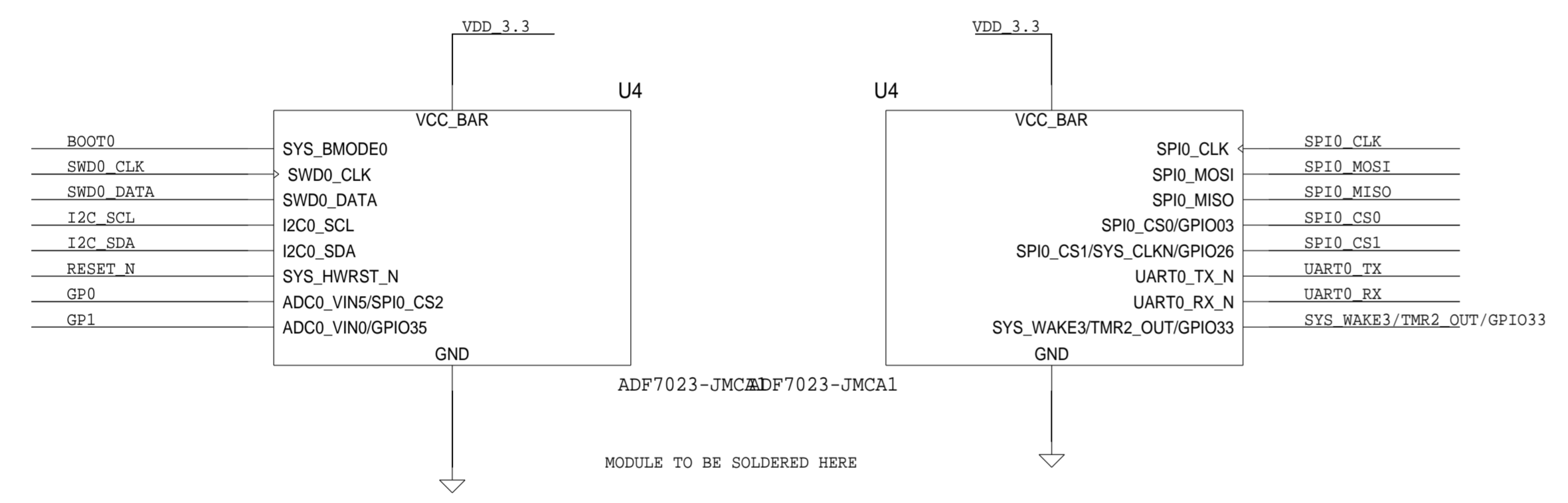

	SCHEMATIC		
	HW TYPE : Customer Evaluation Z Product(s): NA : NA		
	DESIGN VIEW <DESIGN_VIEW>	DRAWING NO. 02_049521	REV B
	PTD ENGINEER S. RAO	SIZE D	SCALE 1:1
		SHEET 2 OF 3	

REVISIONS			
REV	DESCRIPTION	DATE	APPROVED

LDO - 3.3V FOR FT4232

THIS IS NOT REQUIRED IN THE VERSION FOR THE KIT

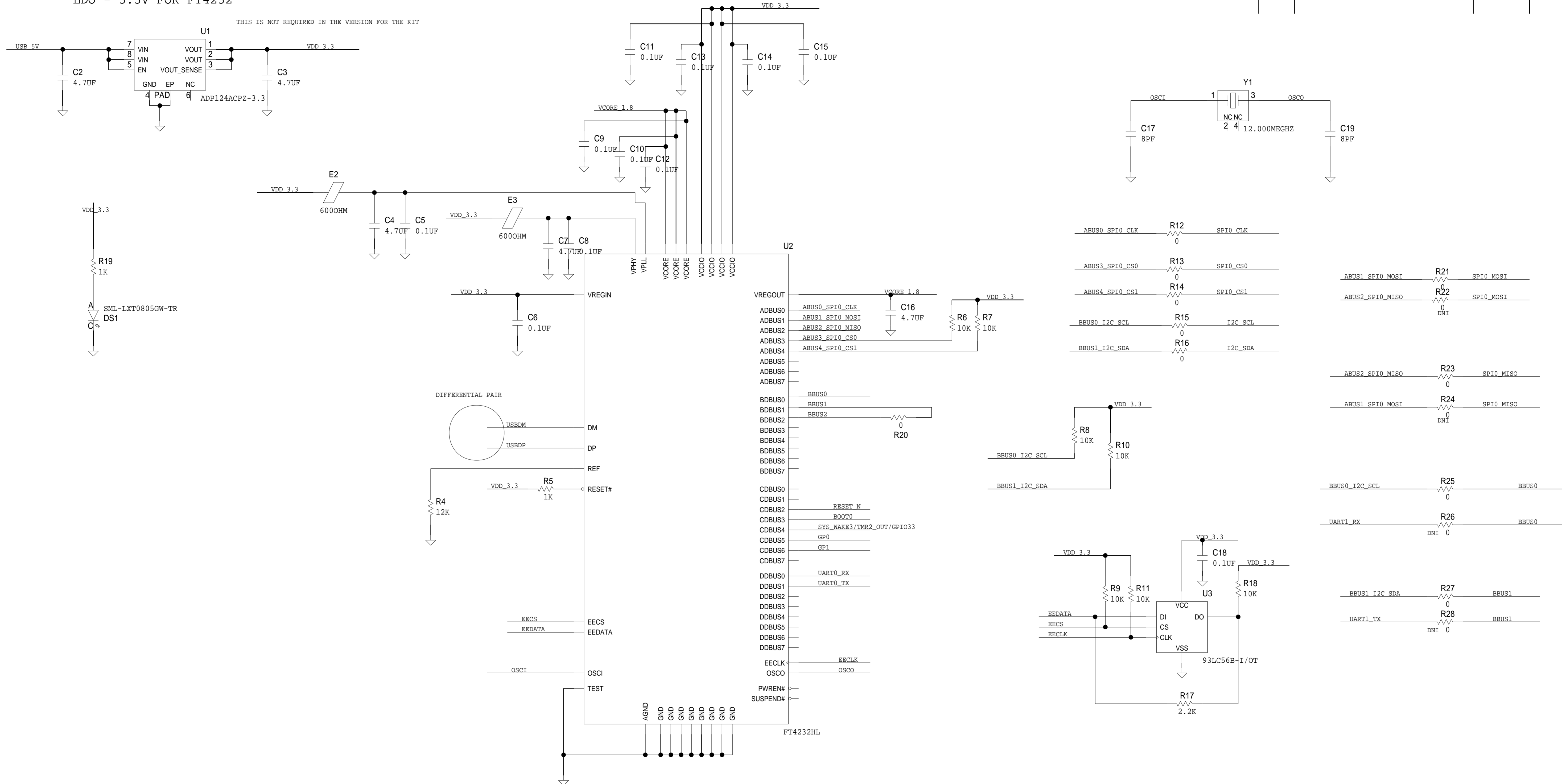

	SCHEMATIC		
	HW TYPE : Customer Evaluation Z		
	Product(s) : NA		
	: NA		
DESIGN VIEW <DESIGN_VIEW>	DRAWING NO. 02_049521	REV B	
PTD ENGINEER S. RAO	SIZE D	SCALE 1:1	SHEET 3 OF 3

THIS DRAWING IS THE PROPERTY OF ANALOG DEVICES INC. IT IS NOT TO BE REPRODUCED OR COPIED, IN WHOLE OR IN PART, OR USED IN ANY MANNER FOR THE PURPOSES OF REPRODUCING INFORMATION TO OTHERS, OR FOR ANY OTHER PURPOSE DETRIMENTAL TO THE INTERESTS OF ANALOG DEVICES. THE EQUIPMENT SHOWN HEREIN MAY BE PROTECTED BY PATENTS OWNED OR CONTROLLED BY ANALOG DEVICES.