

RELAY CONTROL CHART				
CONTROL	CODE	DEVICE	FUNCTION	CONNECTOR

JUMPER TABLE		
JP#	ON	OFF
1		
2		
3		
4		
5		

REVISIONS			
REV	DESCRIPTION	DATE	APPROVED
A	INITIAL RELEASE	15JUN22	N.GARLITOS
B	AS PER ECR-110925	28OCT22	N.GARLITOS

\* SEE ASSEMBLY INSTRUCTIONS

P.O SPEC.	BK/BD SPEC.	SOCKET OEM	OEM PART#	HANDLER

TEMPLATE ENGINEER	DATE
-	
HARDWARE SERVICES	
M.VALE	15JUN22
HARDWARE SYSTEMS	
-	
TEST ENGINEER	
-	
COMPONENT ENGINEER	
A.GIRON	15JUN22
TEST PROCESS	
-	
HARDWARE RELEASE	
K.JABATAN	15JUN22
DESIGNER	
G.GARCIA	15JUN22
PTD ENGINEER	
N.GARLITOS	15JUN22
CHECKER	
-	

<h1>SCHEMATIC</h1>			
HW TYPE : Customer Evaluation Z PACKAGE : LeadCount-lead BodySize PackageType-family : Pitch-pitch StyleVendor Style <User Define> <User Define> <User Define> TBD Product(s): ADAQ400X			
MASTER PROJECT TEMPLATE <MASTER_PROJECT_TEMPLATE>		TESTER TEMPLATE <TESTER_TEMPLATE>	
UNLESS OTHERWISE SPECIFIED DIMENSIONS ARE IN INCHES <b>TOLERANCES</b> DECIMALS X.XX +0.010 X.XXX +0.005		<b>DRAWING NO.</b> 02_071850	
FRACTIONS +-1/32 ANGLES +2		<b>REV.</b> B	
SIZE <b>C</b>	SCALE 1:1	CODE ID NO. CodeID	SHEET 1 OF 3

REVISIONS			
REV	DESCRIPTION	DATE	APPROVED

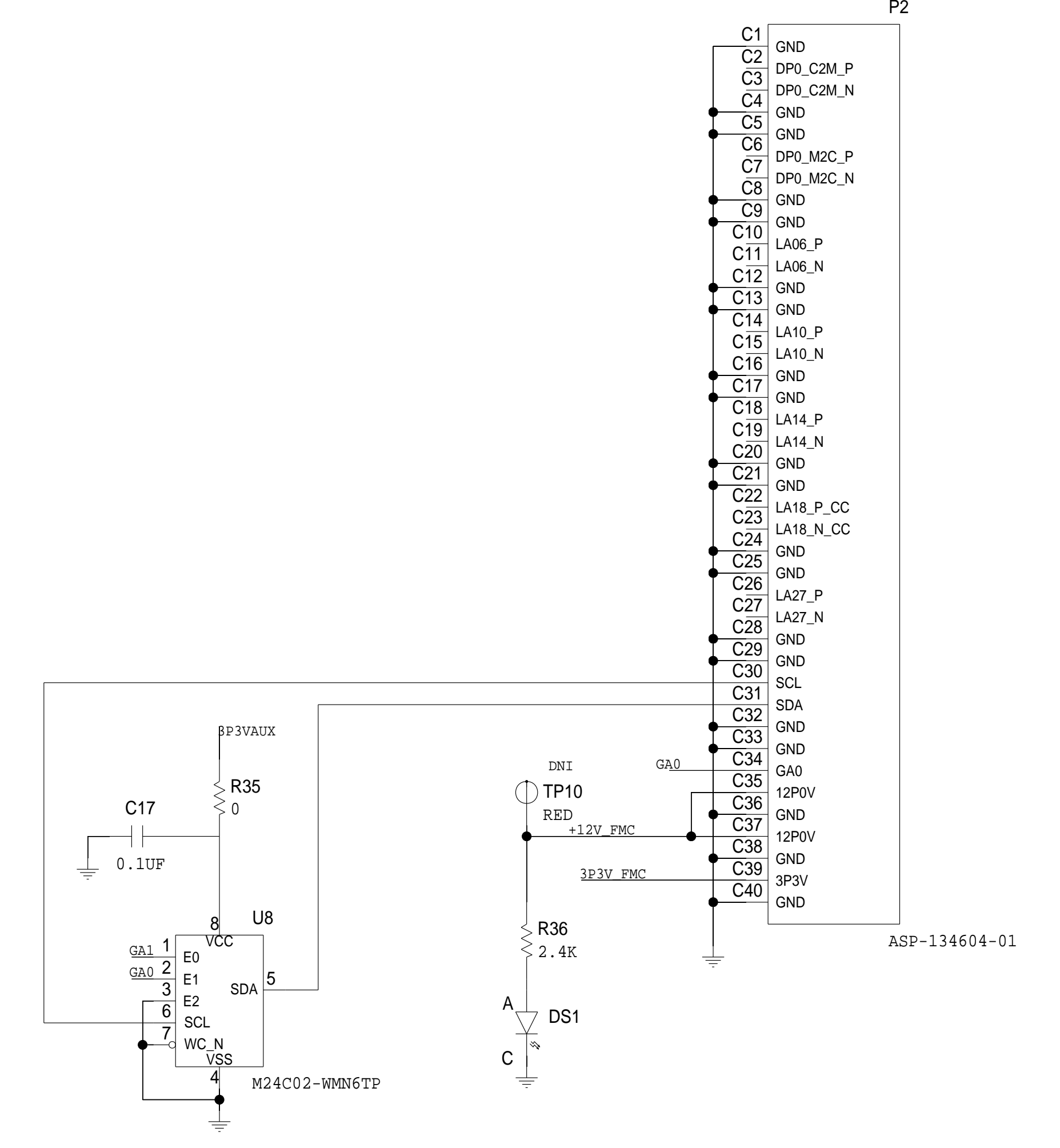
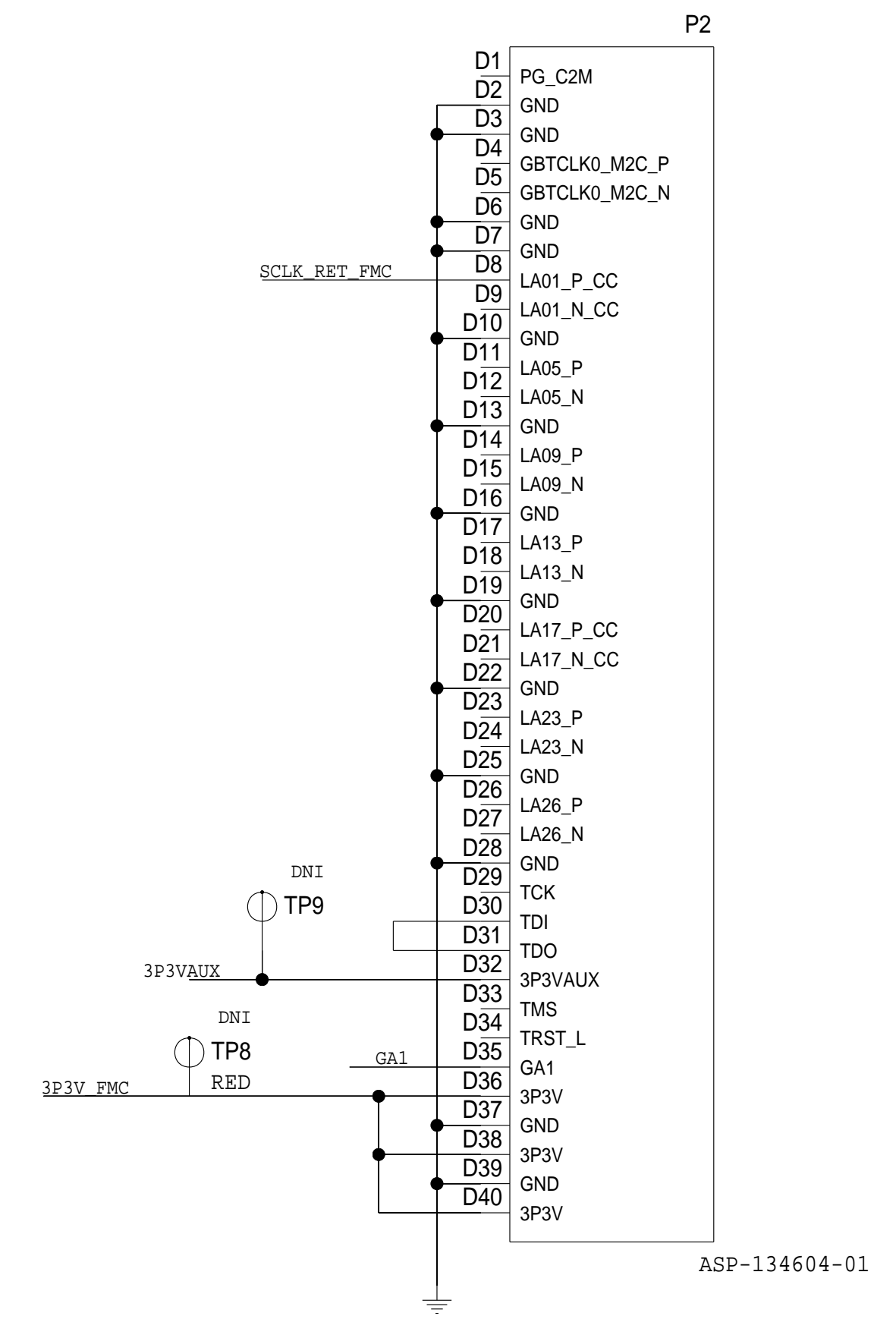
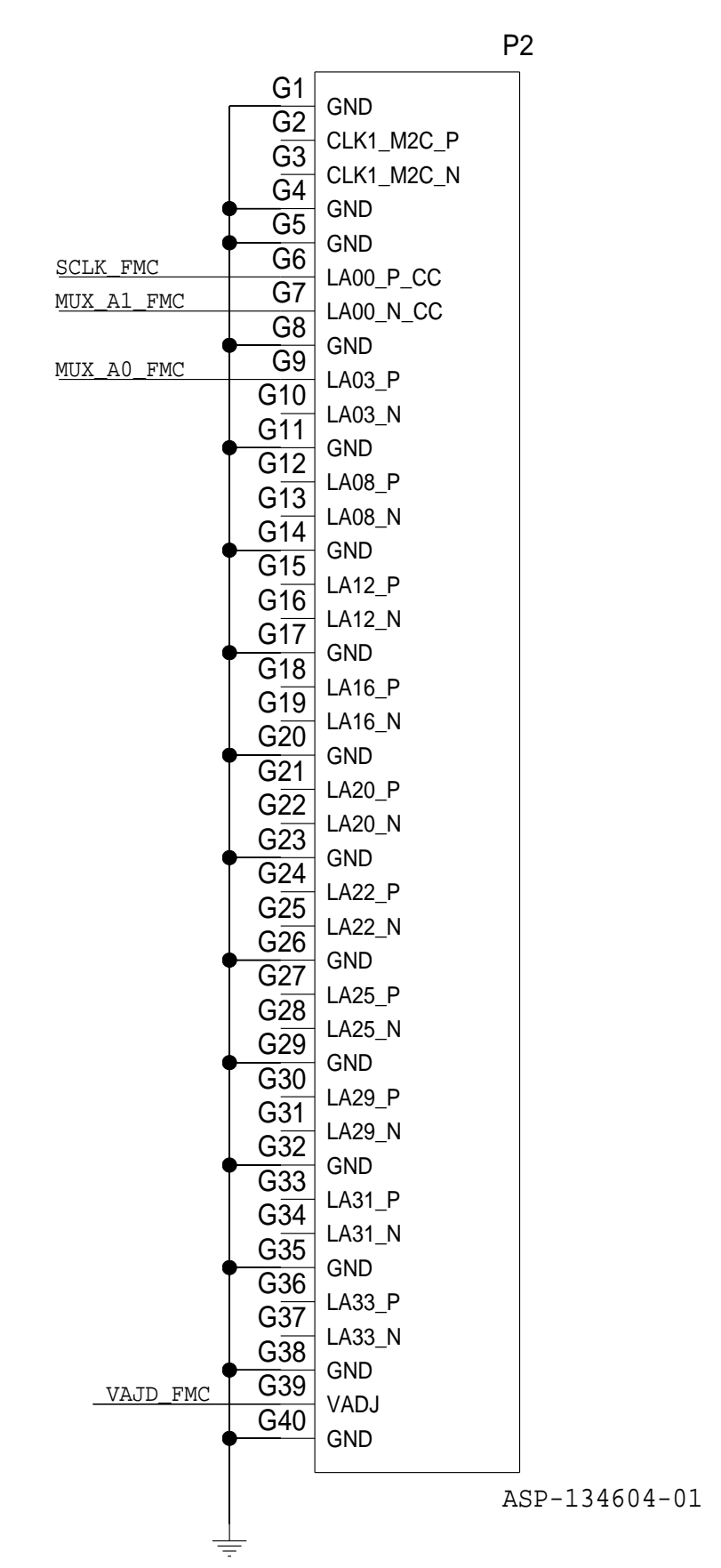
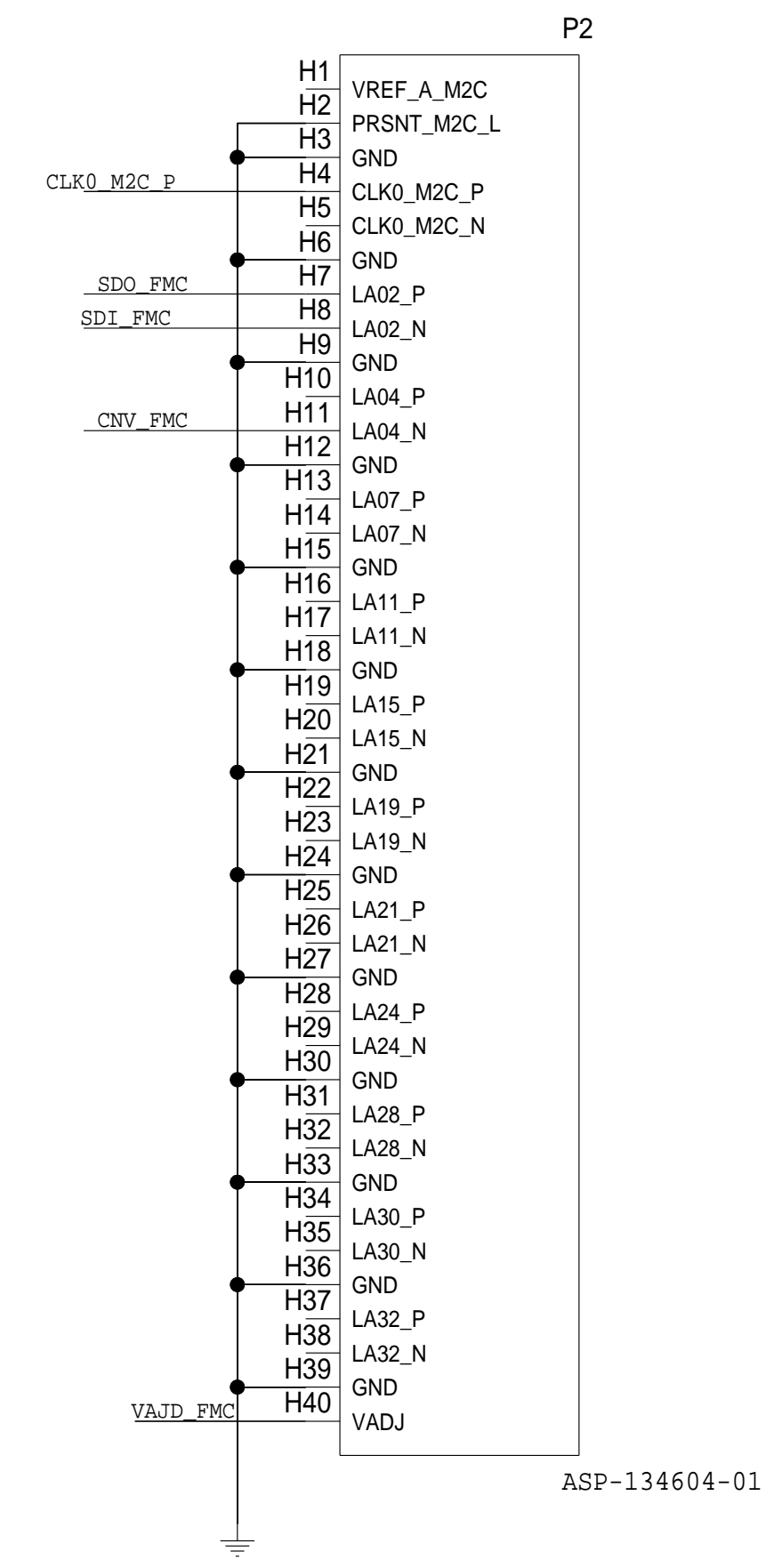
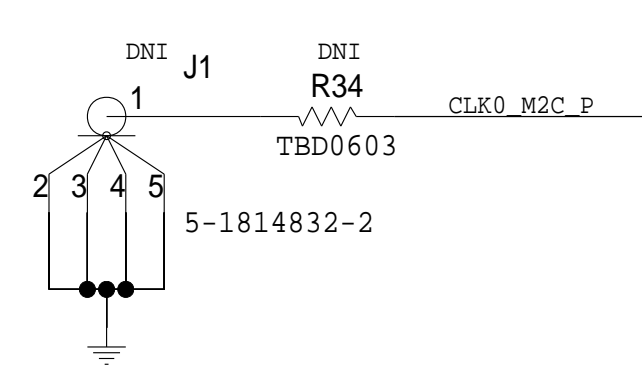

	<b>SCHEMATIC</b>		
	HW TYPE : Customer Evaluation Z Product(s) : ADAQ400X : LT3999		
	DESIGN VIEW <DESIGN_VIEW>	DRAWING NO. 02_071850	REV B
PTD ENGINEER N. GARLITOS	SIZE D	SCALE 1:1	SHEET 2 OF 3

REVISIONS			
REV	DESCRIPTION	DATE	APPROVED

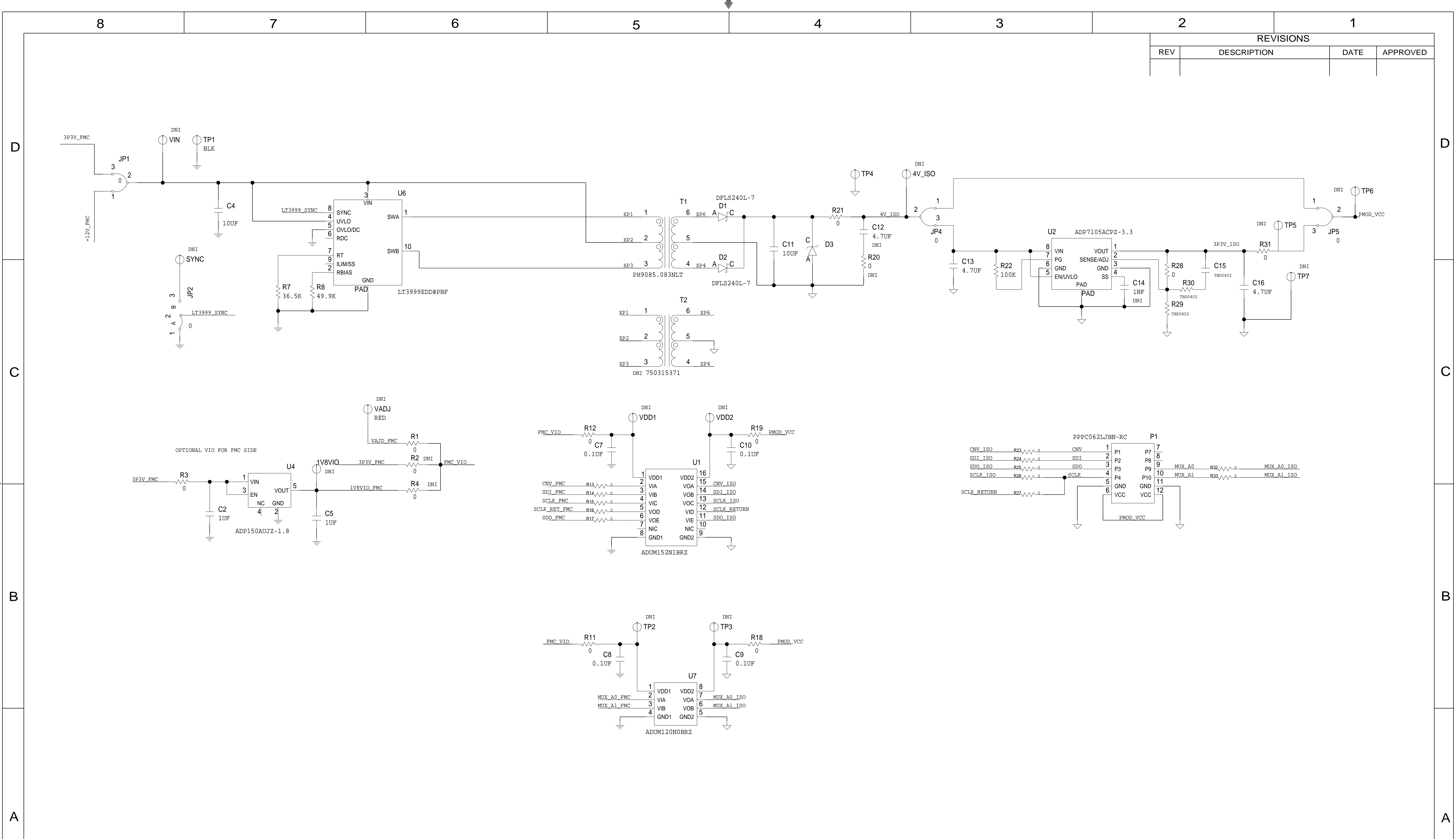

	<b>SCHEMATIC</b>		
	HW TYPE : Customer Evaluation Z Product(s): ADAQ400X : LT3999		
	DESIGN VIEW <DESIGN_VIEW>	DRAWING NO. 02_071850	REV B
	PTD ENGINEER N. GARLITOS	SIZE D	SCALE 1:1
		SHEET 3 OF 3	