

THIS DRAWING IS THE PROPERTY OF ANALOG DEVICES INC. IT IS NOT TO BE REPRODUCED OR COPIED, IN WHOLE OR IN PART, OR USED IN FURNISHING INFORMATION TO OTHERS, OR FOR ANY OTHER PURPOSE DETRIMENTAL TO THE INTERESTS OF ANALOG DEVICES. THE EQUIPMENT SHOWN HEREON MAY BE PROTECTED BY PATENTS OWNED OR CONTROLLED BY ANALOG DEVICES.

REVISIONS			
REV	DESCRIPTION	DATE	APPROVED

EVAL-AD4170-4WARDZ SCHEMATIC REV (C)

PAGE 2 - TOP VIEW

PAGE 3 - J1 AND J2 CONNECTORS

PAGE 4 - J3 CONNECTOR

PAGE 5 - BOARD POWER

PAGE 6 - REFERENCE AND GPIOS

PAGE 7 - AD4170 DUT

PAGE 8 - DIGITAL

P.O. SPEC.	BK/BD SPEC.	SOCKET OEM	OEM PART#	HANDLER

TEMPLATE ENGINEER -	DATE	SCHEMATIC		
HARDWARE SERVICES PAT SHEAHAN				
HARDWARE SYSTEMS -		HW TYPE: Customer Evaluation EVAL-AD7140-ASDZ		
TEST ENGINEER -		: Currently N/A		
COMPONENT ENGINEER -		PACKAGE : 32-lead 4X6X0.75 LFCSP-family : Pitch-pitch StyleVendor Style		
TEST PROCESS -		<User Define>		
HARDWARE RELEASE -		<User Define>		
DESIGNER -		MASTER PROJECT TEMPLATE TBD	TESTER TEMPLATE N/A	DRAWING NO. 02-067069
PTD ENGINEER SEAN CAHILL		UNLESS OTHERWISE SPECIFIED DIMENSIONS ARE IN INCHES		
CHECKER -		TOLERANCES		
		DECIMALS X.XX +0.010 X.XXX +0.005	FRACTIONS +1/32	ANGLES +2
		SIZE D	SCALE 1:1	CODE ID NO. CodeID
				SHEET 1 OF 8
				REV. E

BOARD POWER

REVISIONS			
REV	DESCRIPTION	DATE	APPROVED

J3
GPIO
GPIO
AC INPUTS/DACOUT
ADXL1002 CIRCUIT
AIN2 - DC FILTERING
AIN7/AIN8 - AC FILTERING
AIN3/AIN4 - AC FILTERING
INSIDE BLOCK

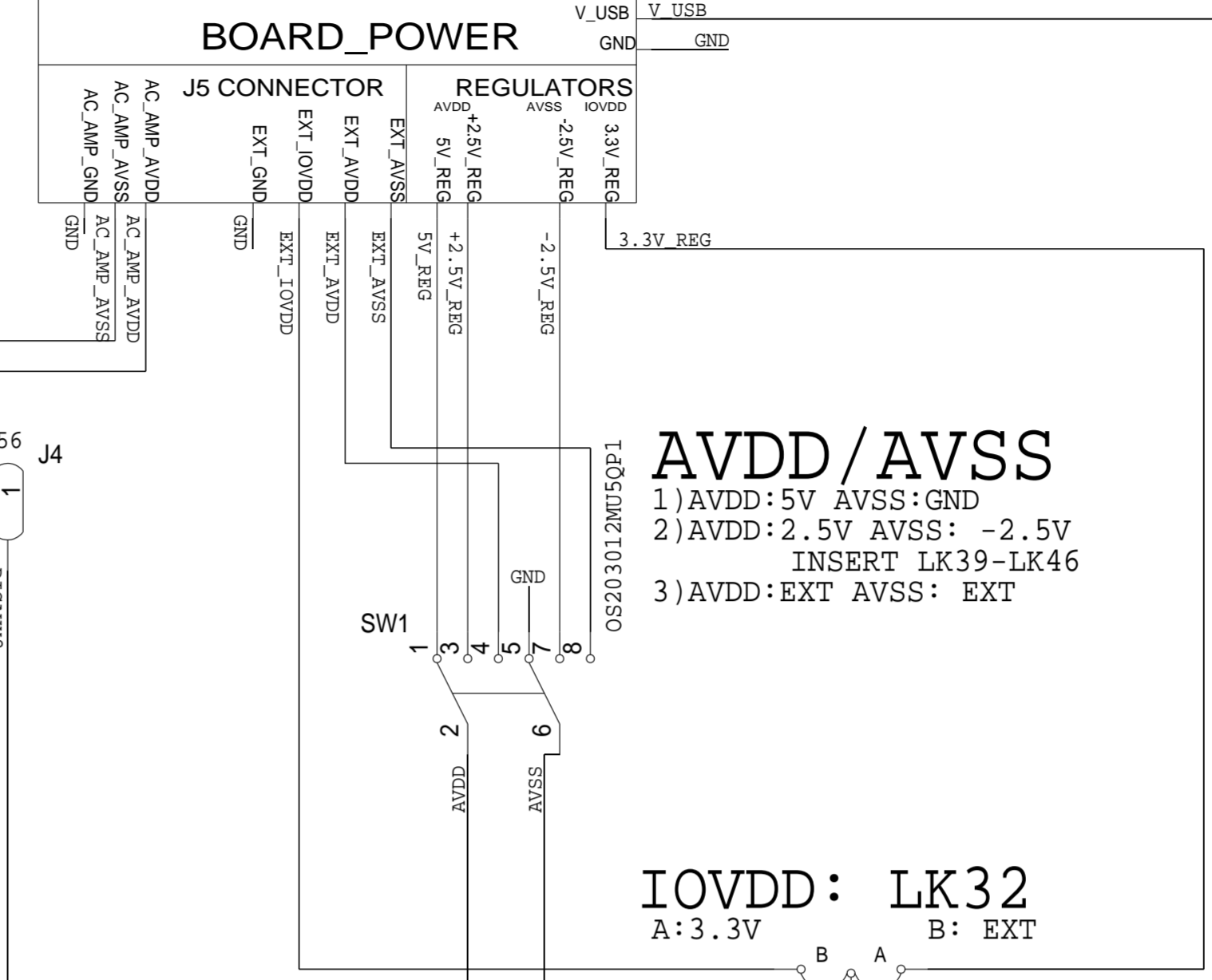

AVSS/GND LINKS

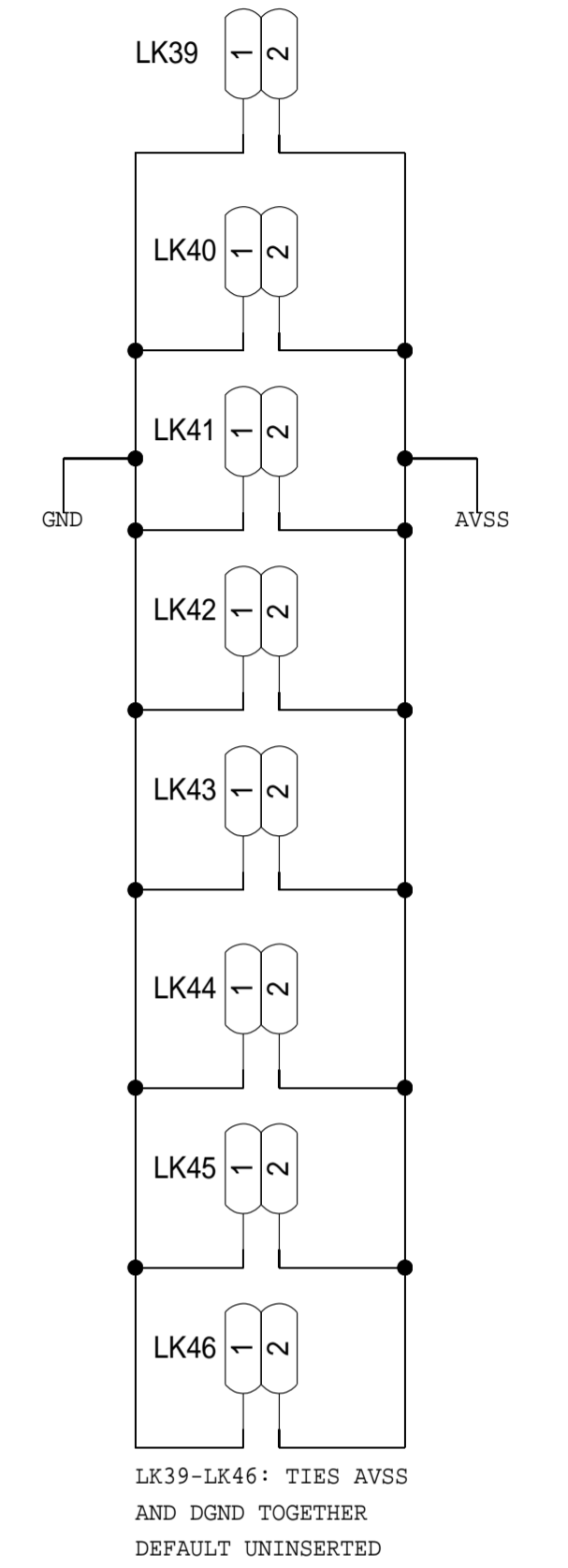

AVDD/AVSS
 1) AVDD: 5V AVSS: GND
 2) AVDD: 2.5V AVSS: -2.5V
 INSERT LK39-LK46
 3) AVDD: EXT AVSS: EXT

IOVDD: LK32
 A: 3.3V B: EXT

AIN7/AIN8
INPUT OPTIONS:
 2) DC - CONNECTOR J1
 3) AC - CONNECTOR J3

AIN3/AIN4
INPUT OPTIONS:
 2) DC - CONNECTOR J1
 3) AC - CONNECTOR J3

AIN2
INPUT OPTIONS:
 1) ADXL1002 VOUT
 2) DC - CONNECTOR J3

GPIO
FUNCTIONALITY
 GPIO0/GPIO1 REFIN/PSW/IOUT J3
 GPIO2/GPIO3 IOUT/PSW
 GPIO1 PSW FOR WIRE BRIDGE

REFERENCE SELECT
INPUT OPTIONS:
 1) REFIN+ - CONNECTOR J1/PRECISION R
 2) REFIN1 - CONNECTOR J2
 3) REFIN1 - CONNECTOR J2

REFERENCE
REFERENCE OPTIONS
 1) LK3
 2) LK3
 3) LK3
 4) CONNECTOR 2

REFERENCE
 LTC6655/ADR4525 OUT
 LTC6655_OUT
 LTC6655_OUT

DIGITAL

CONTROLLER BOARD OPTIONS
 1) 120 PIN SMD
 2) ARDINO HEADER
 3) PMOD CONNECTION

DIGITAL

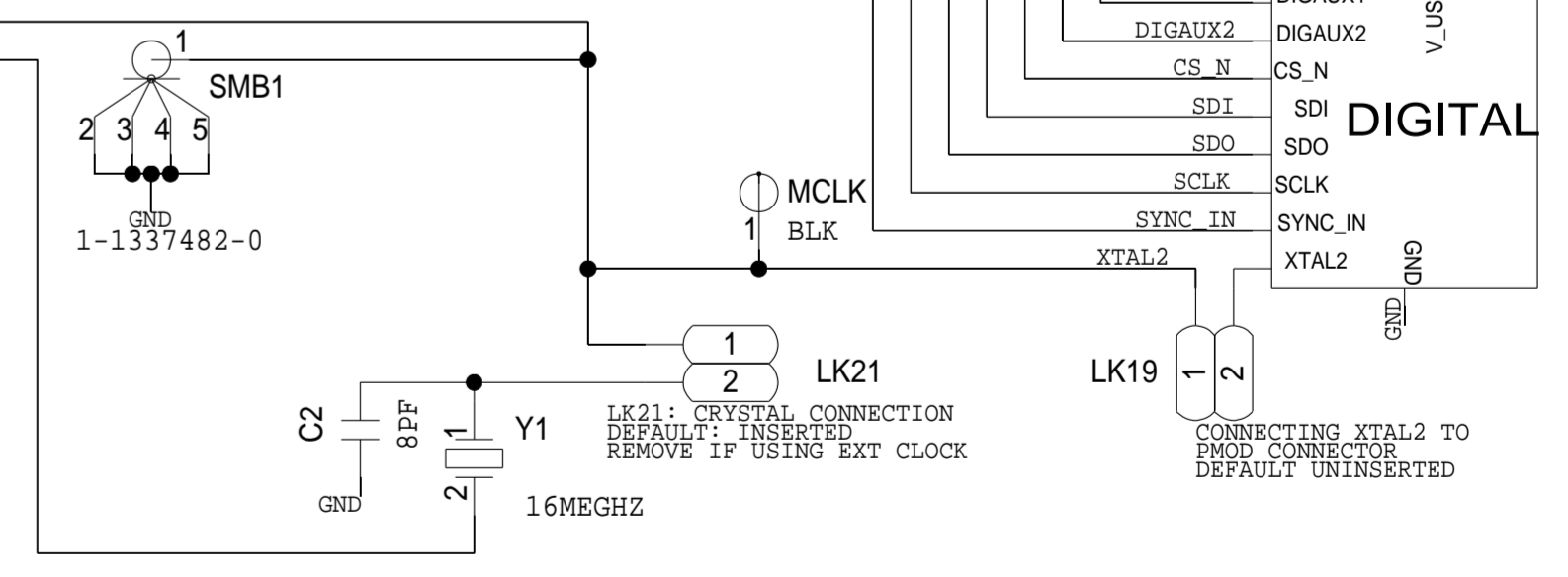

SCHEMATIC			
HW TYPE: Customer Evaluation EVAL-AD7140-ASDZ : Currently N/A			
DESIGN VIEW <DESIGN_VIEW>	DRAWING NO. 02-067069	REV E	
PTD ENGINEER SEAN CAHILL	SIZE D	SCALE 1:1	SHEET 2 OF 8

D
C
B
A

D
C
B
A

8 7 6 5 4 3 2 1

8 7 6 5 4 3 2 1

J3 CONNECTOR

REVISIONS			
REV	DESCRIPTION	DATE	APPROVED

J3 CONNECTOR

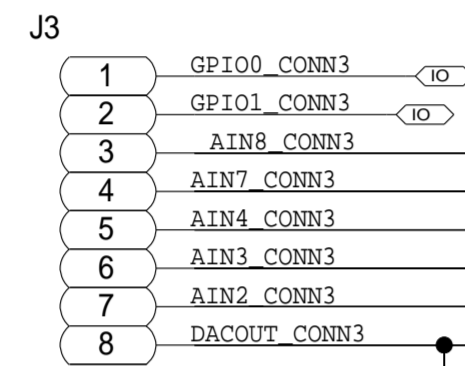

SMB CONNECTION

AIN3, AIN4, AIN7, AIN8

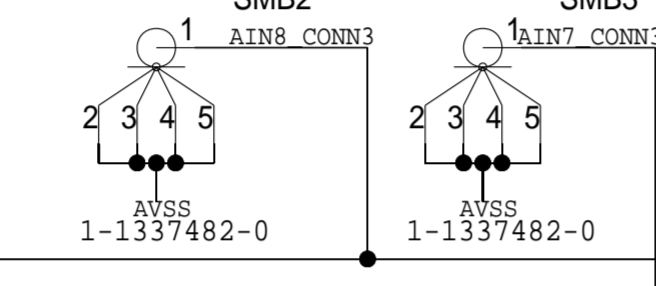

AIN2 DC FILTERING

NOTE: FILTERS DESIGNED FOR ANTI-ALIASING OVER/UNDER VOLTAGE PROTECTION IS NOT INCLUDED

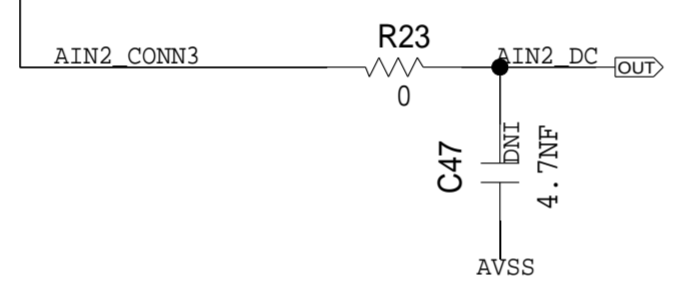

VOCM SELECT

AIN7/AIN8

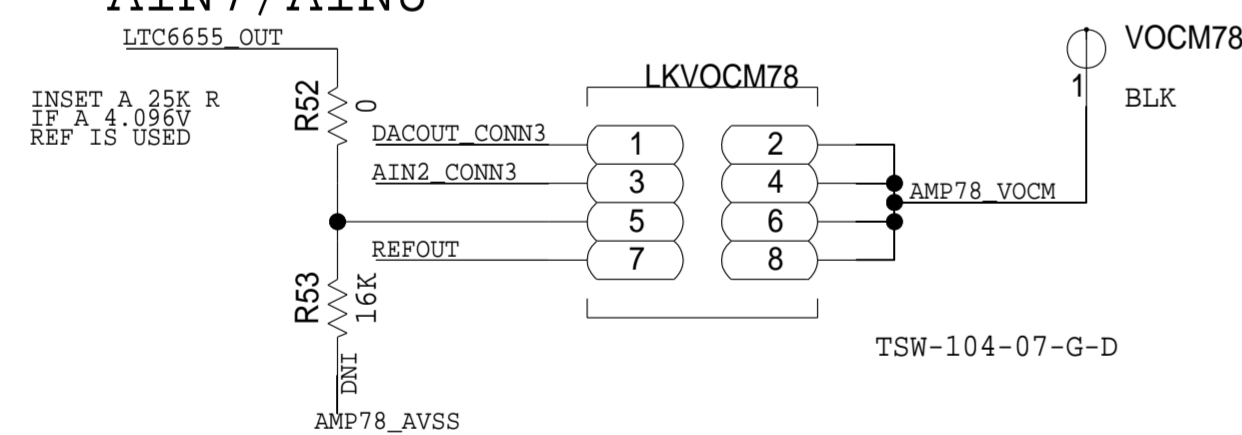

AVDD SELECT

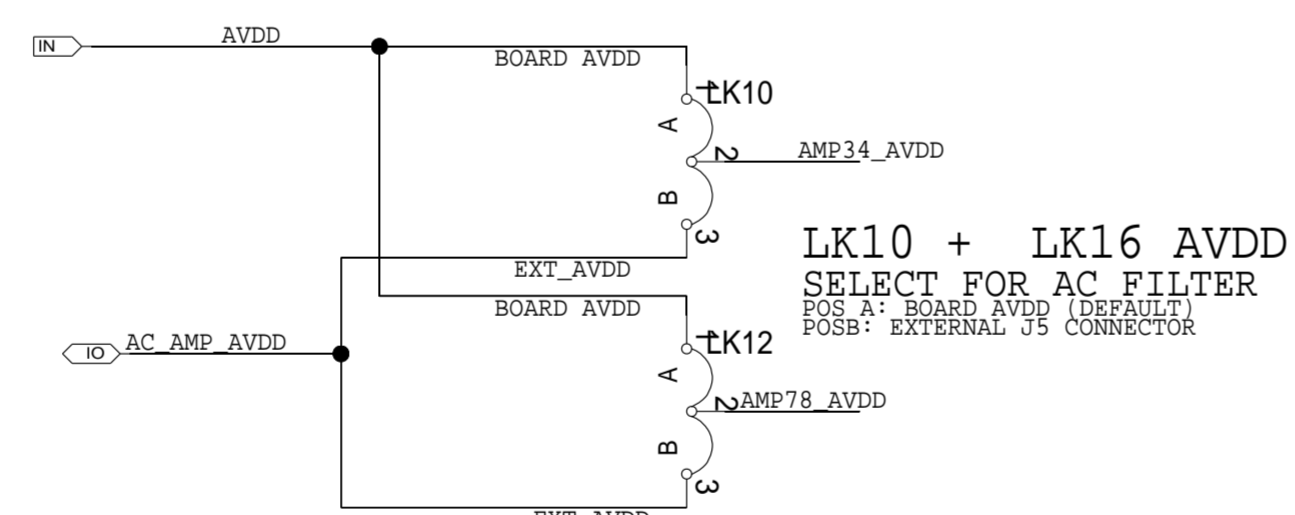

AVSS SELECT

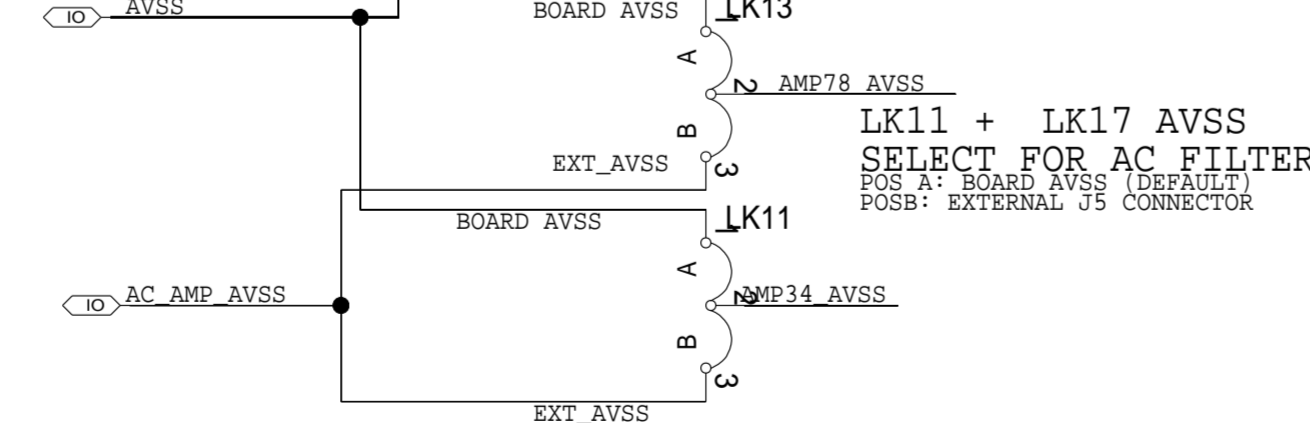

AIN3/AIN4

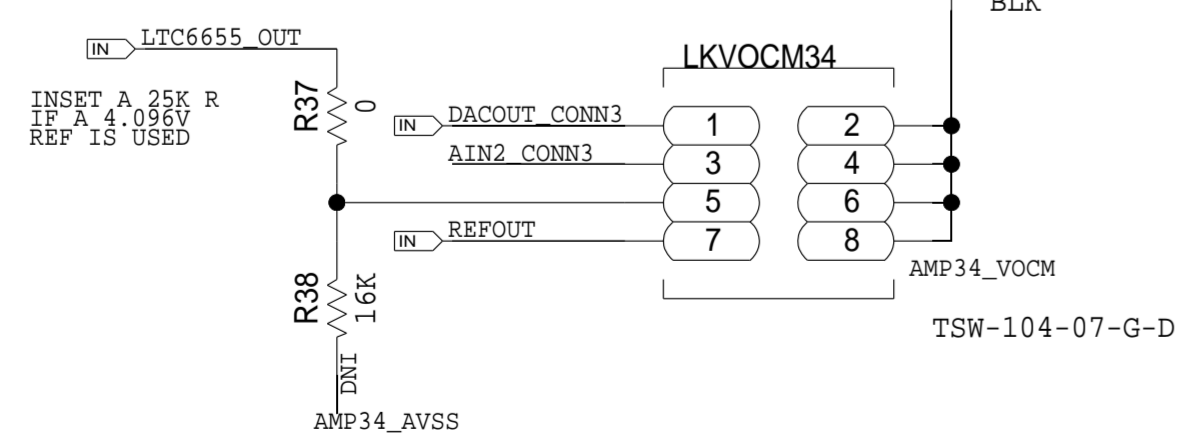

22US SETTLING

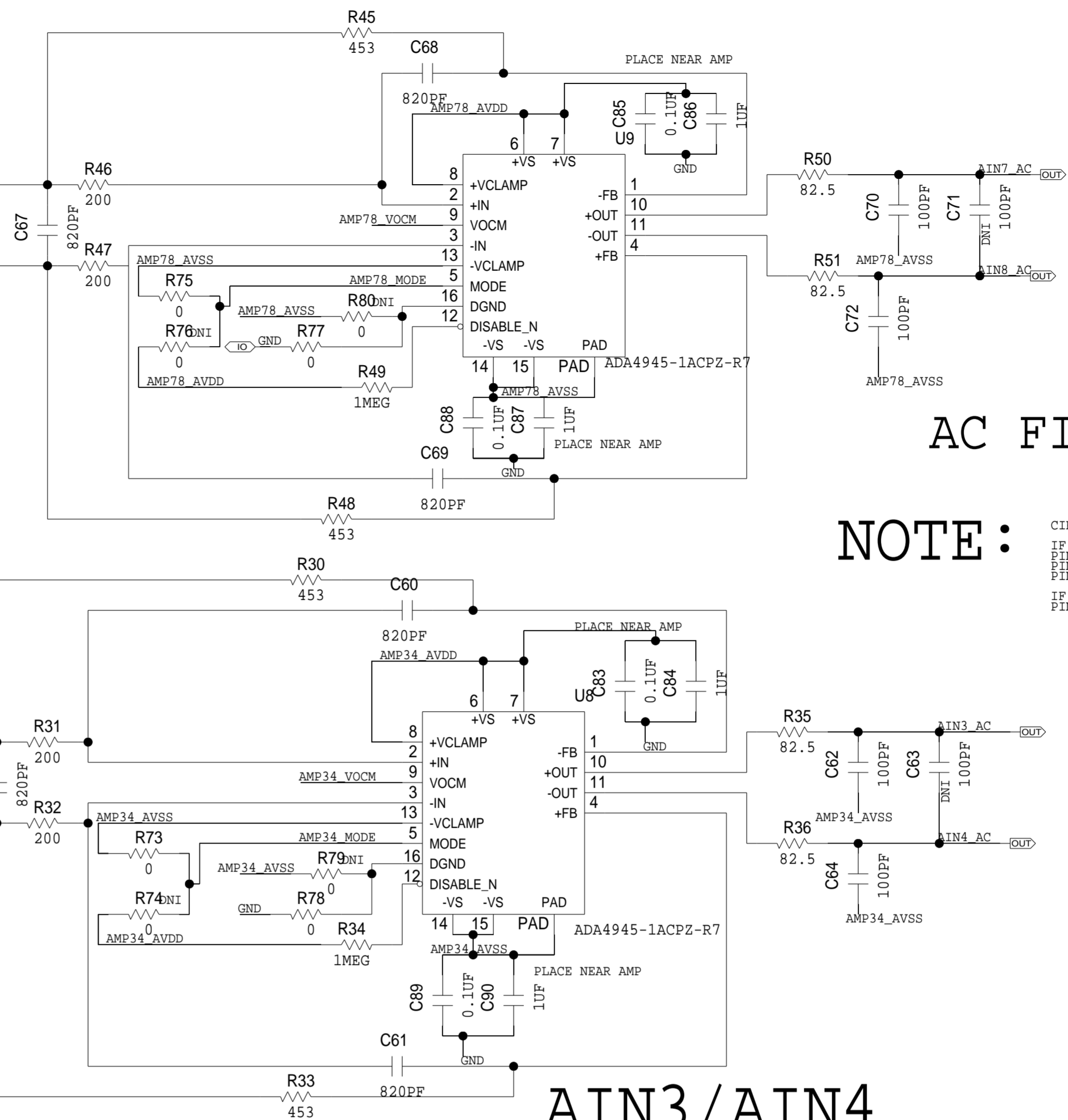

AIN7/AIN8 AC FILTERING

AIN3/AIN4 AC FILTERING

NOTE: CIRCUITS TO THE LEFT ARE FOR USE WITH THE ADA4945-1
 IF USING THE ADA4940 OR THE LTC6363:
 PIN 5: CONNECT TO AMP_AVDD
 PIN 12: CONNECT TO AMP_AVSS
 PIN 14: CONNECT TO AVSS
 IF USING THE ADA4945 IN HIGH POWER MODE:
 PIN 5: CONNECT TO AMP_AVDD

ADXL1002

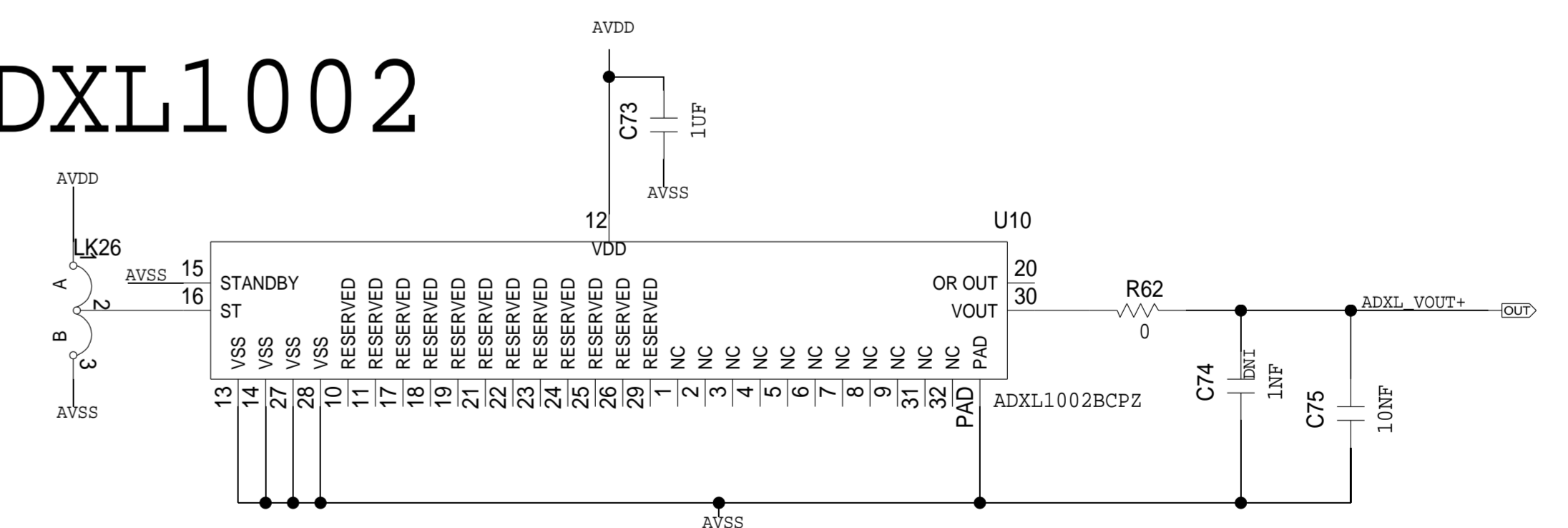

ANALOG DEVICES		SCHEMATIC	
HW TYPE: Customer Evaluation		EVAL-AD7140-ASDZ	
DESIGN VIEW		DRAWING NO. 02-067069	
<DESIGN VIEW>		REV E	
PTD ENGINEER SEAN CAHILL		SIZE D	SCALE 1:1
		SHEET 3	OF 8

J2 CONNECTOR

4/6 WIIRE BRIDGE

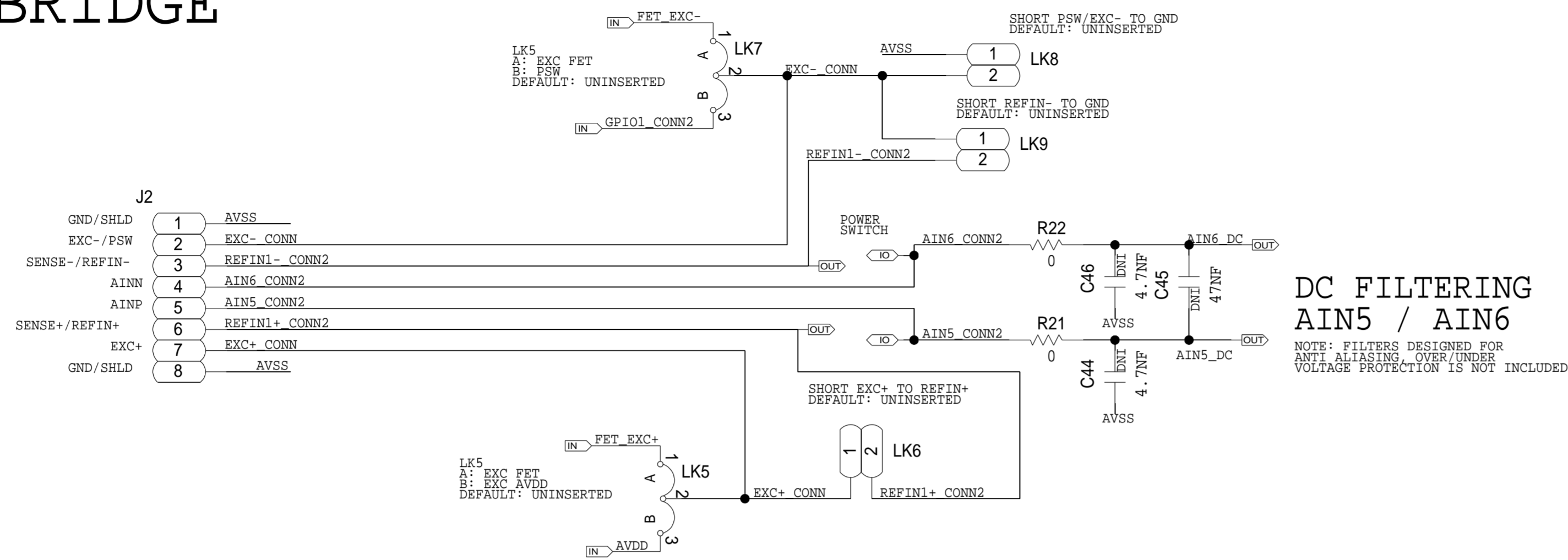

J1 CONNECTOR

RTD
THERMOCOUPLE
REFOUT
GPIO2/3 (EXCITATION CURRENT)

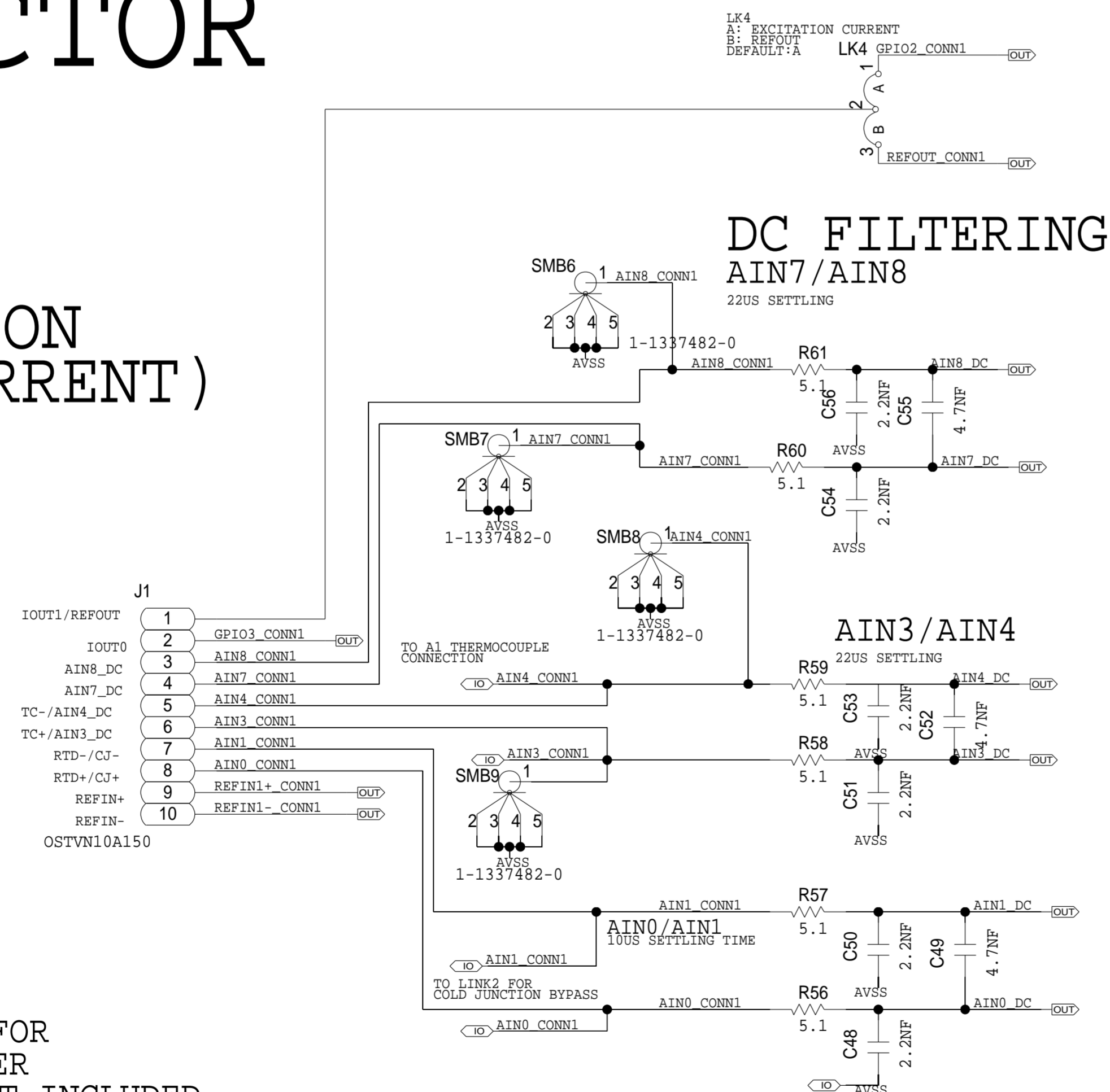

NOTE: FILTERS DESIGNED FOR ANTI ALIASING, OVER/UNDER VOLTAGE PROTECTION IS NOT INCLUDED

REVISIONS			
REV	DESCRIPTION	DATE	APPROVED

ANALOG DEVICES				SCHEMATIC			
<small>THIS DRAWING IS THE PROPERTY OF ANALOG DEVICES INC. IT IS NOT TO BE REPRODUCED OR COPIED, IN WHOLE OR IN PART, OR USED IN ANY MANNER THAT WOULD BE DETRIMENTAL TO THE INTERESTS OF ANALOG DEVICES. THE EQUIPMENT SHOWN HEREIN MAY BE PROTECTED BY PATENTS OWNED OR CONTROLLED BY ANALOG DEVICES.</small>				HW TYPE: Customer Evaluation EVAL-AD7140-ASDZ : Currently N/A			
				DESIGN VIEW <DESIGN_VIEW>		DRAWING NO. 02-067069	
PTD ENGINEER SEAN CAHILL		SIZE D	SCALE 1:1	SHEET 4 OF 8			

AD4170 DUT

REVISIONS			
REV	DESCRIPTION	DATE	APPROVED

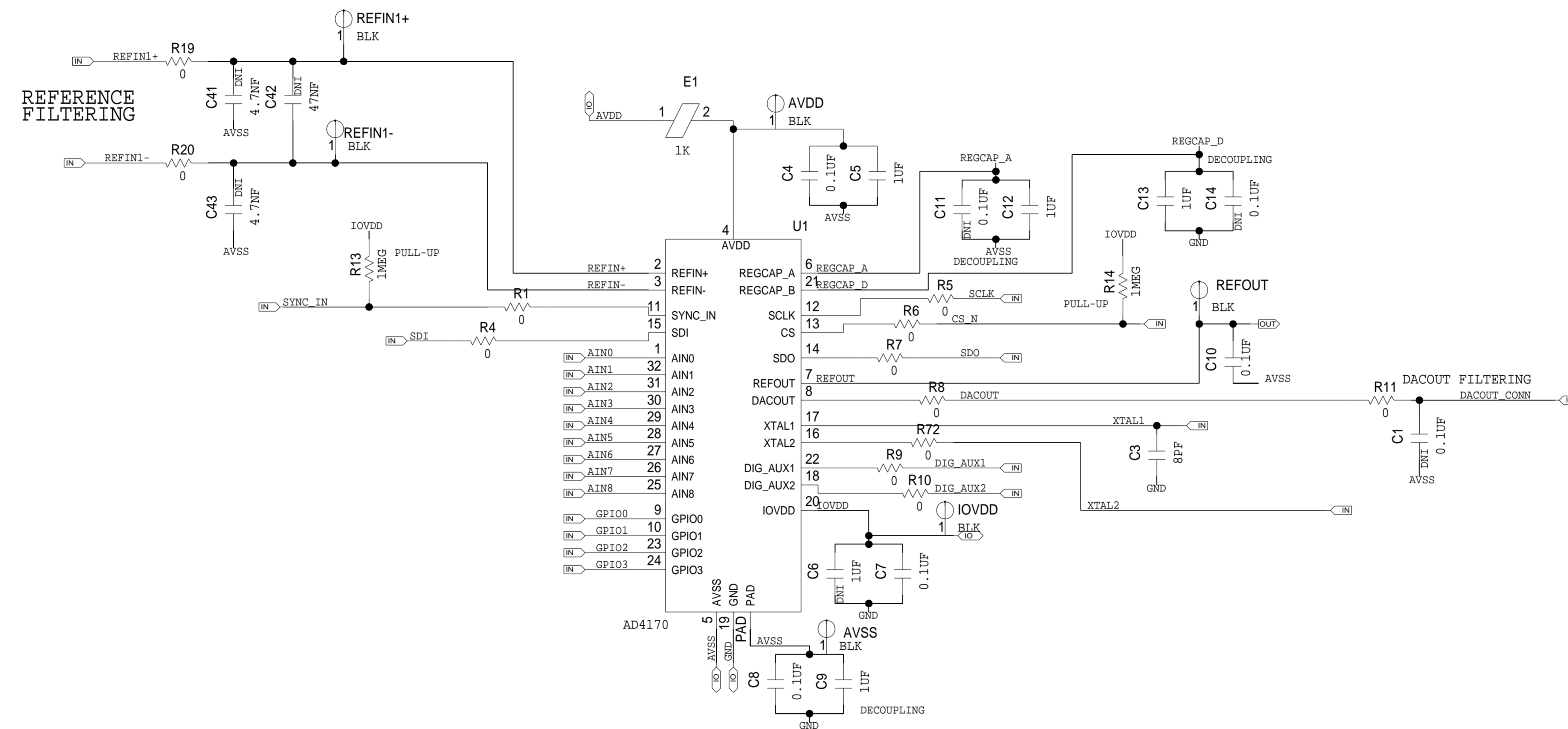

ANALOG DEVICES				SCHEMATIC			
<small>THIS DRAWING IS THE PROPERTY OF ANALOG DEVICES INC. IT IS NOT TO BE REPRODUCED OR COPIED, IN WHOLE OR IN PART, OR USED FOR ANY OTHER PURPOSE DETRIMENTAL TO THE INTERESTS OF ANALOG DEVICES. THE EQUIPMENT SHOWN HEREIN MAY BE PROTECTED BY PATENTS OWNED OR CONTROLLED BY ANALOG DEVICES.</small>				HW TYPE: Customer Evaluation EVAL-AD7140-ASDZ : Currently N/A			
				DESIGN VIEW <DESIGN_VIEW>		DRAWING NO. 02-067069	
PTD ENGINEER SEAN CAHILL		SIZE D	SCALE 1:1	SHEET 5 OF 8			

DIGITAL

REVISIONS			
REV	DESCRIPTION	DATE	APPROVED

PMOD CONNECTOR

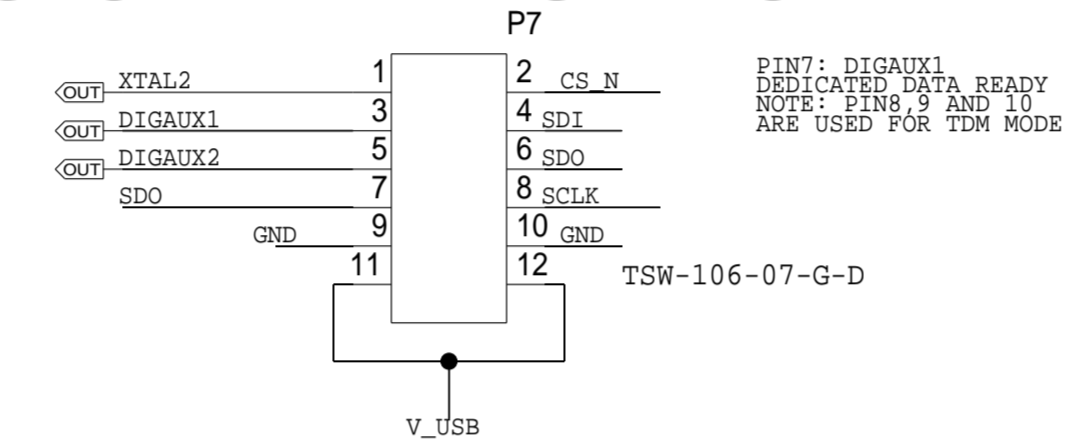

ARDUINO CONNECTOR

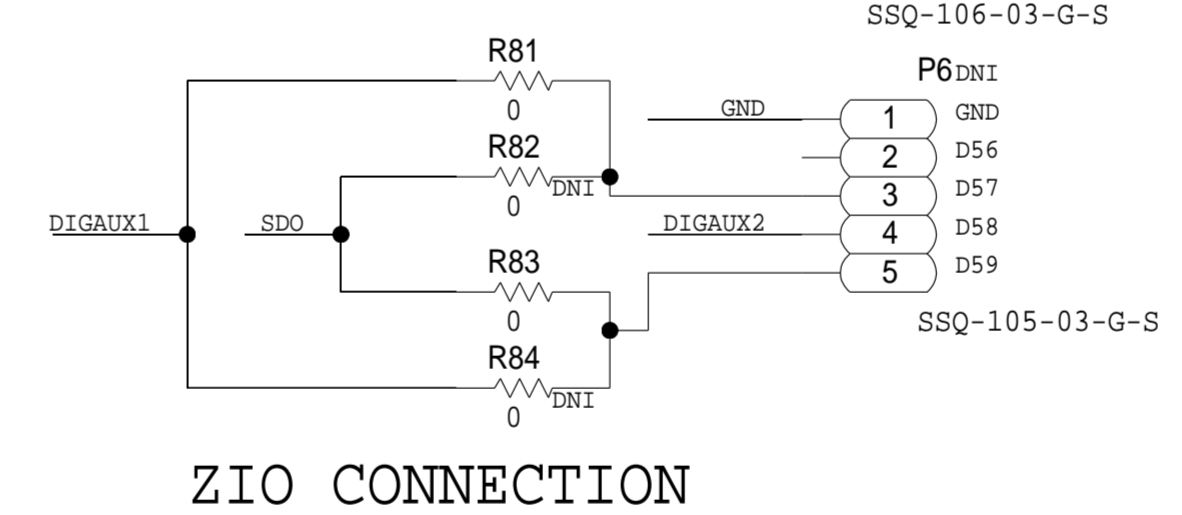
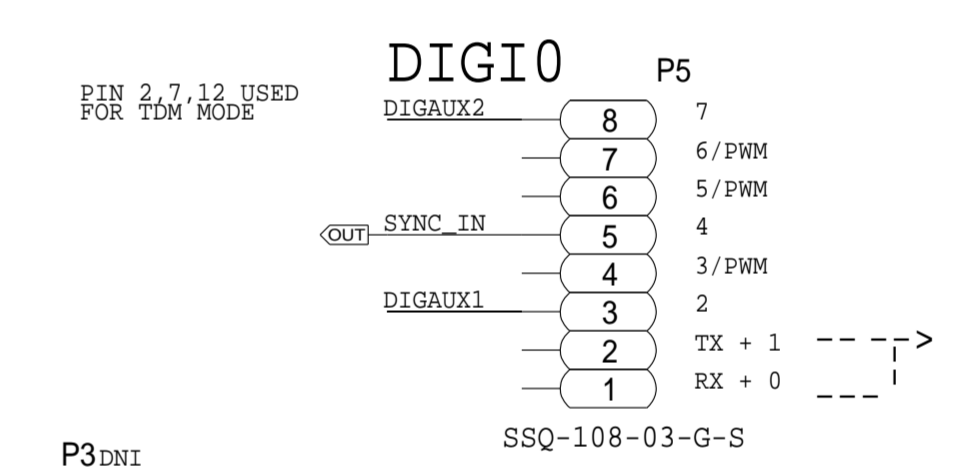
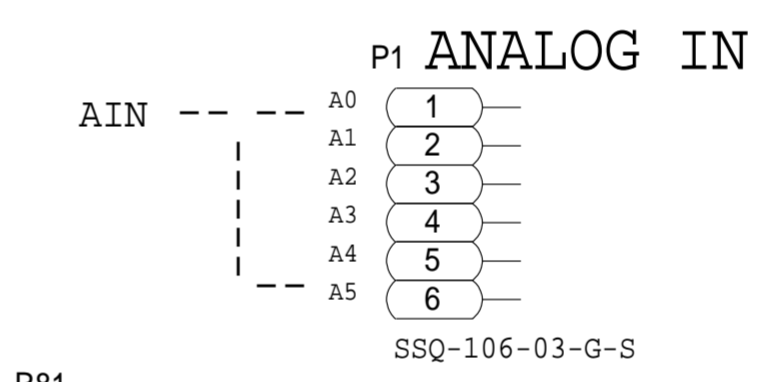
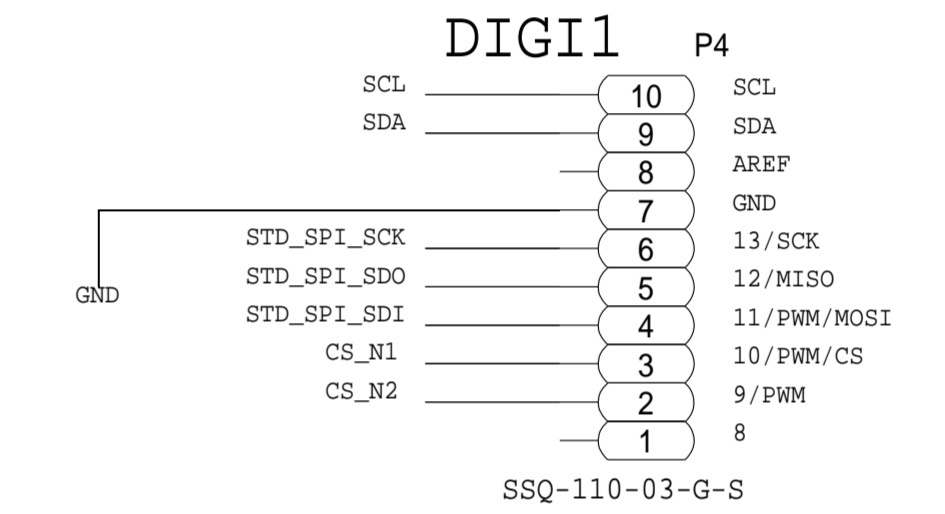
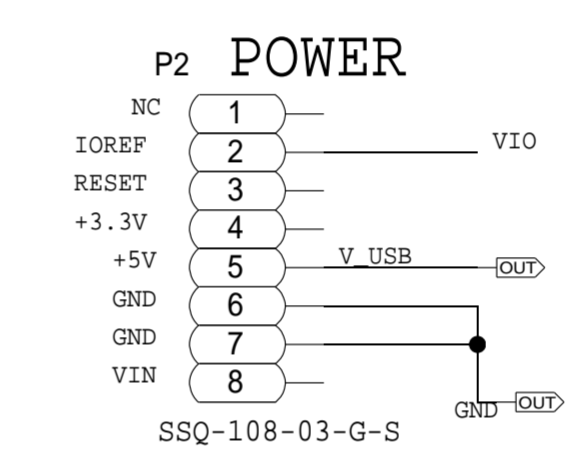
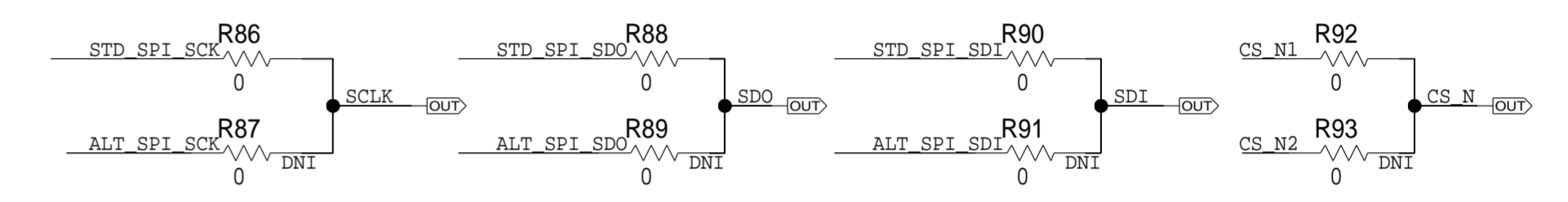

EEPROM CONNECTOR

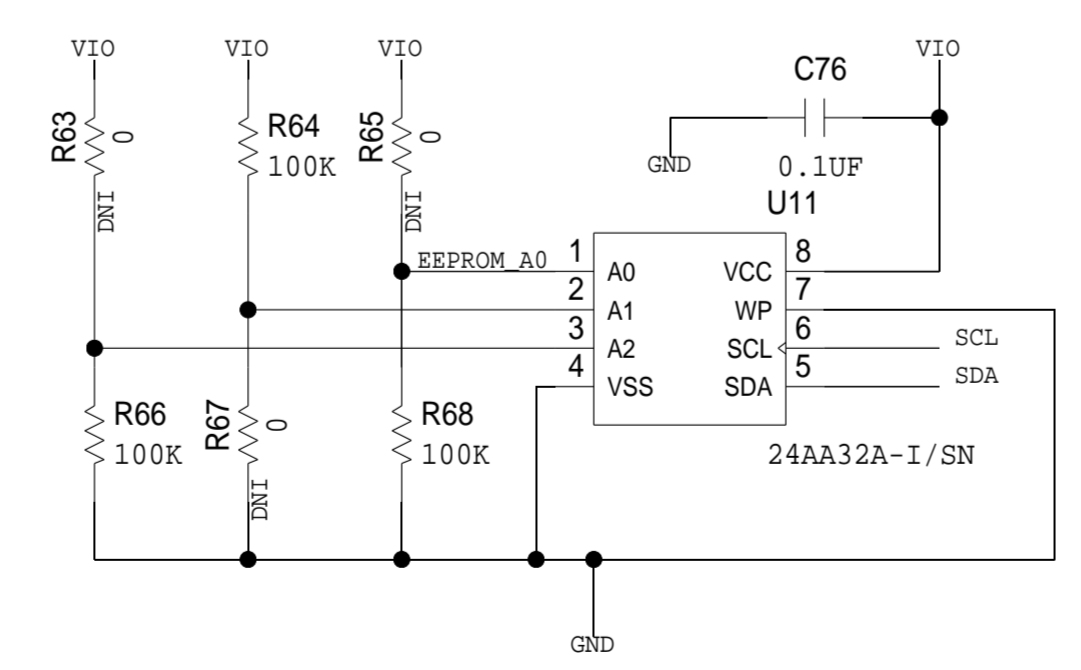

	SCHEMATIC		
	HW TYPE: Customer Evaluation EVAL-AD7140-ASDZ : Currently N/A		
	DESIGN VIEW <DESIGN_VIEW>	DRAWING NO. 02-067069	REV E
	PTD ENGINEER SEAN CAHILL	SIZE D	SCALE 1:1

BOARD POWER

REVISIONS			
REV	DESCRIPTION	DATE	APPROVED

AVDD

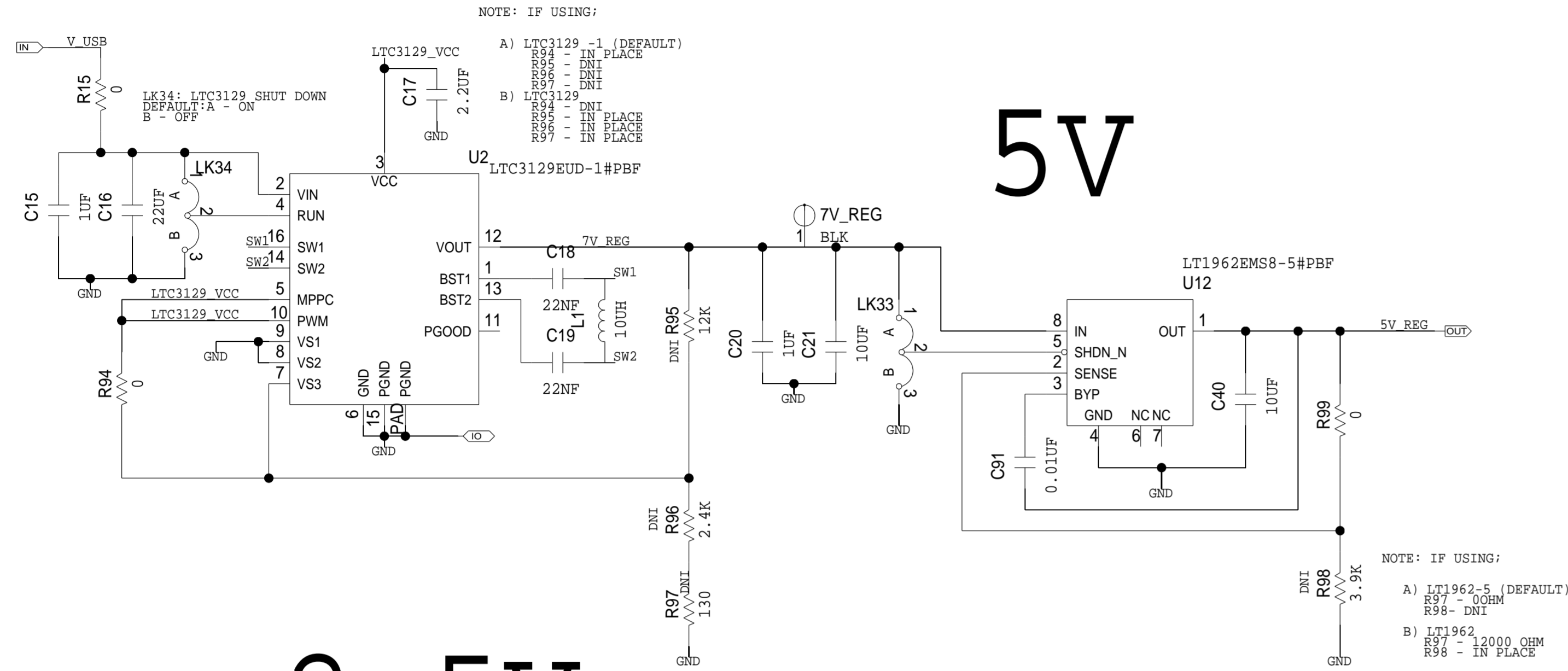

IOVDD 3.3V

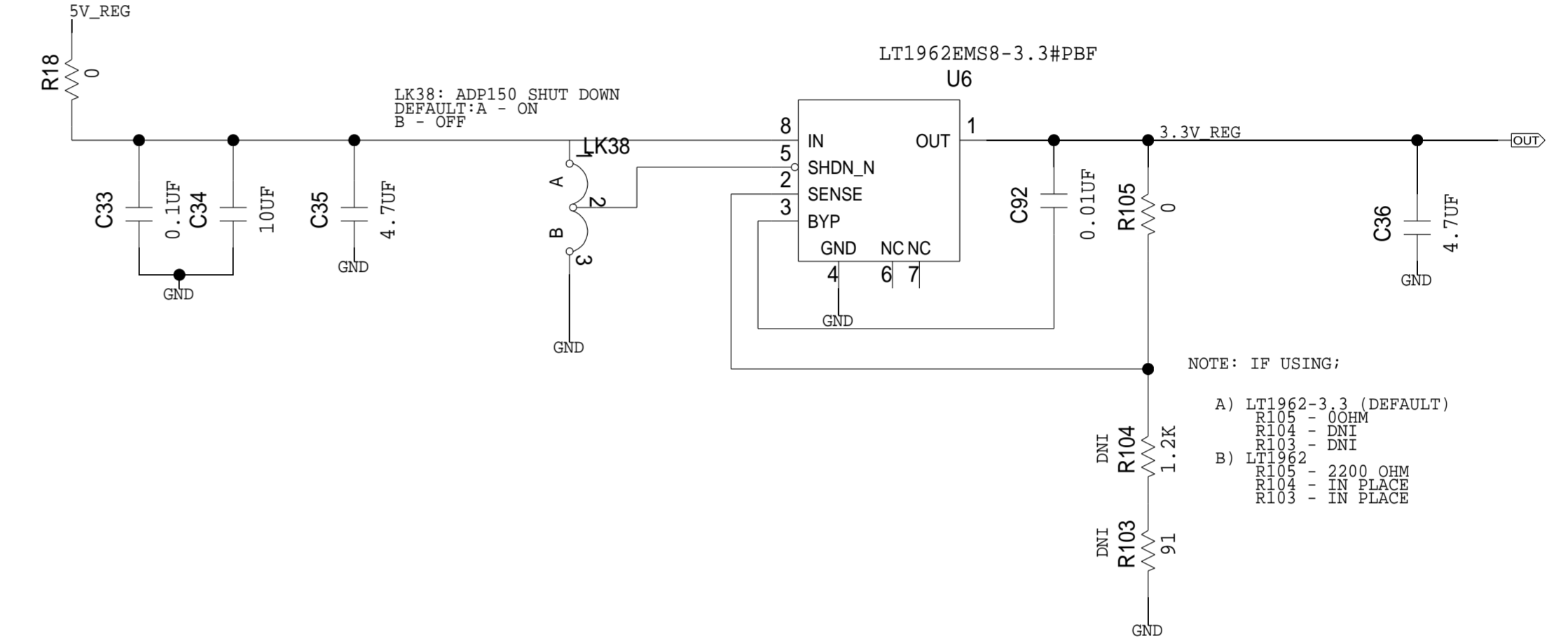

2.5V

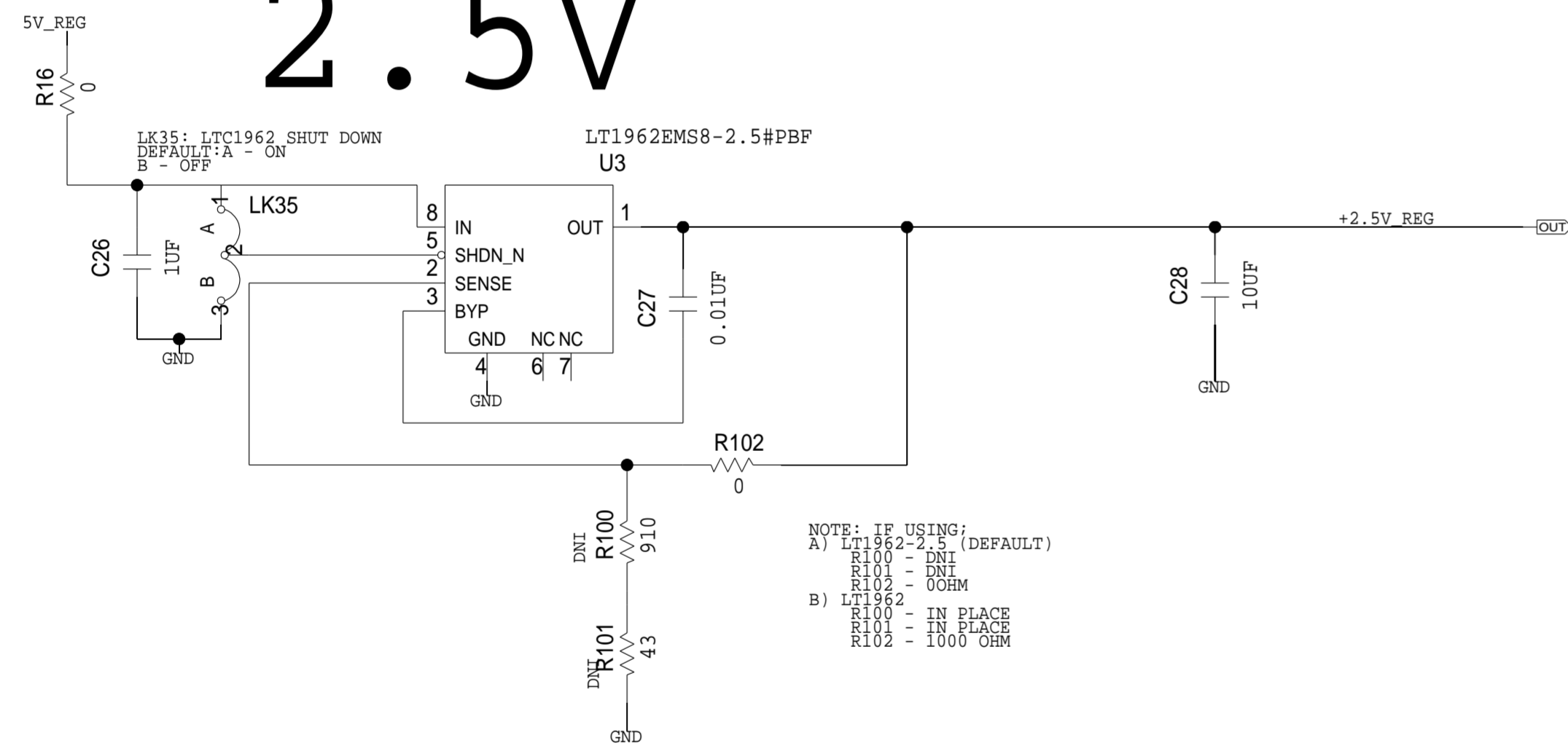

EXT POWER

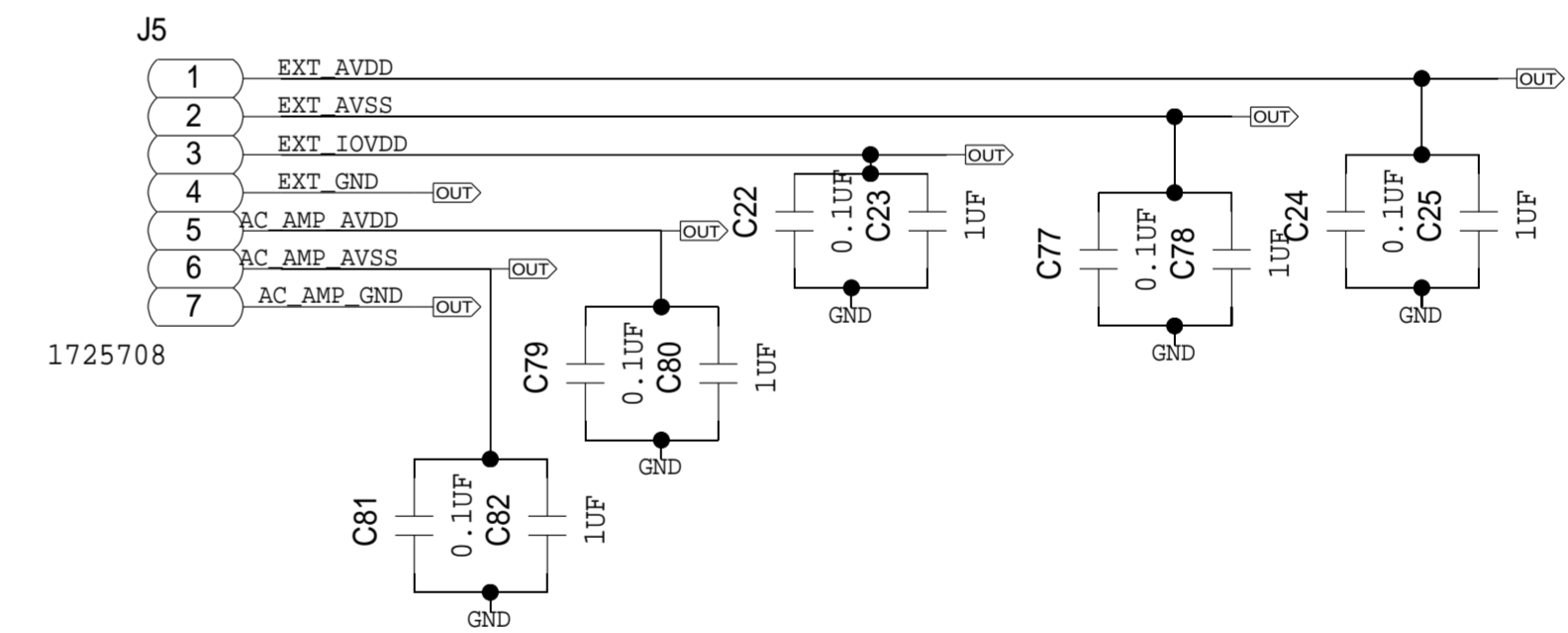

SCP CONNECTIONS

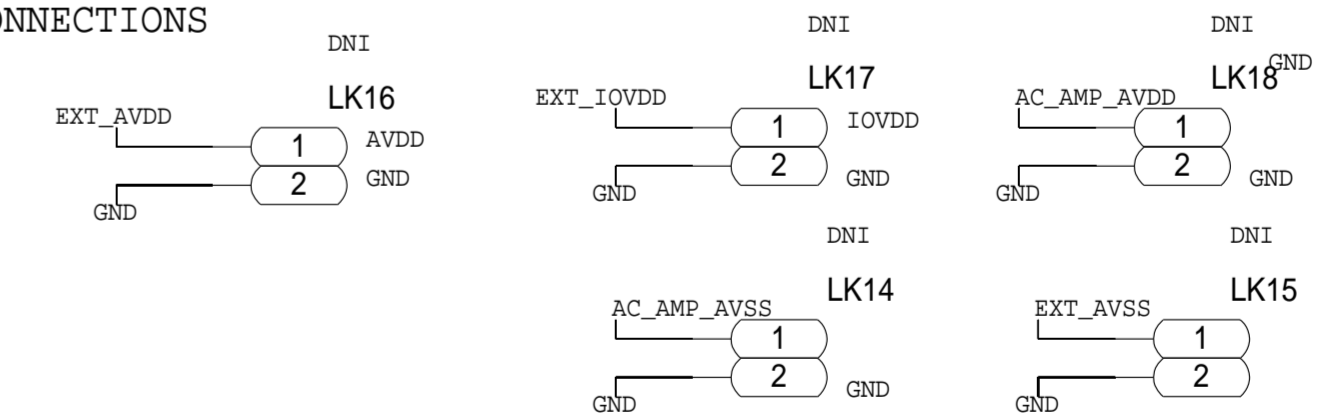

AVSS -2.5V

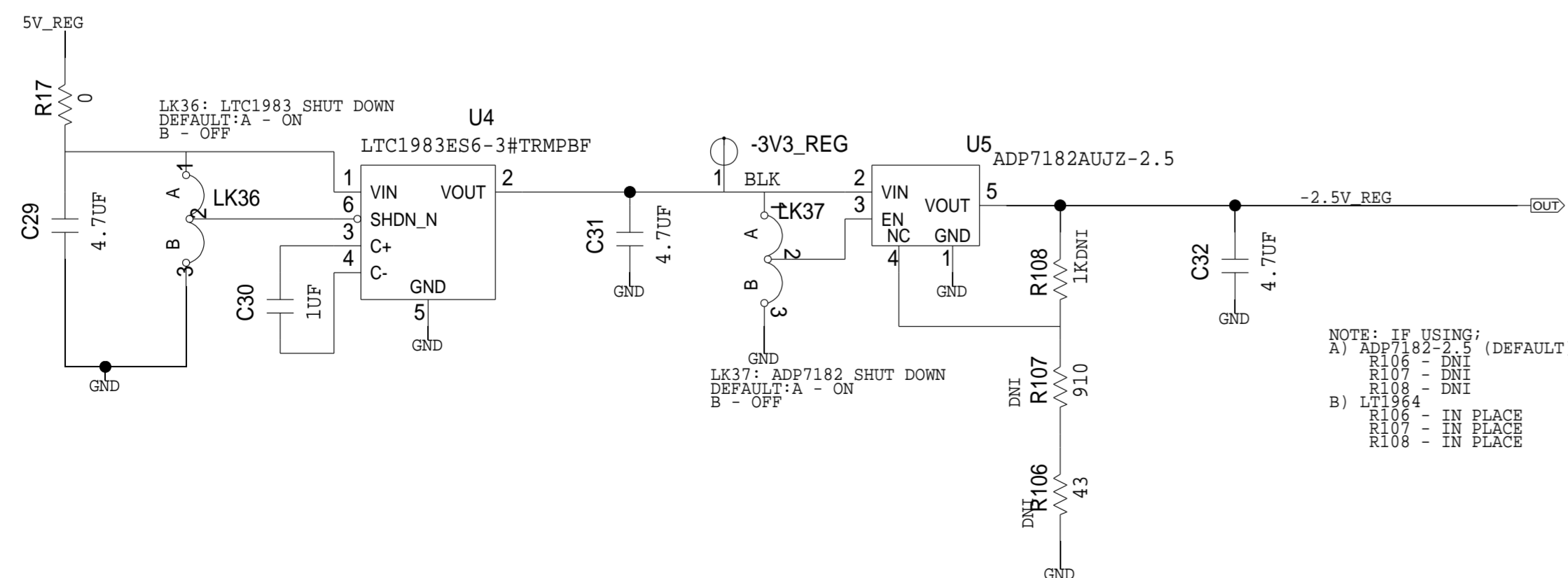

ANALOG DEVICES		SCHEMATIC			
HW TYPE: Customer Evaluation EVAL-AD7140-ASDZ : Currently N/A		DESIGN VIEW <DESIGN_VIEW>		DRAWING NO. 02-067069	
PTD ENGINEER SEAN CAHILL		SIZE D		SCALE 1:1	
		SHEET 7		OF 8	

REFERENCE AND GPIO

REFERENCE STRUCTURE

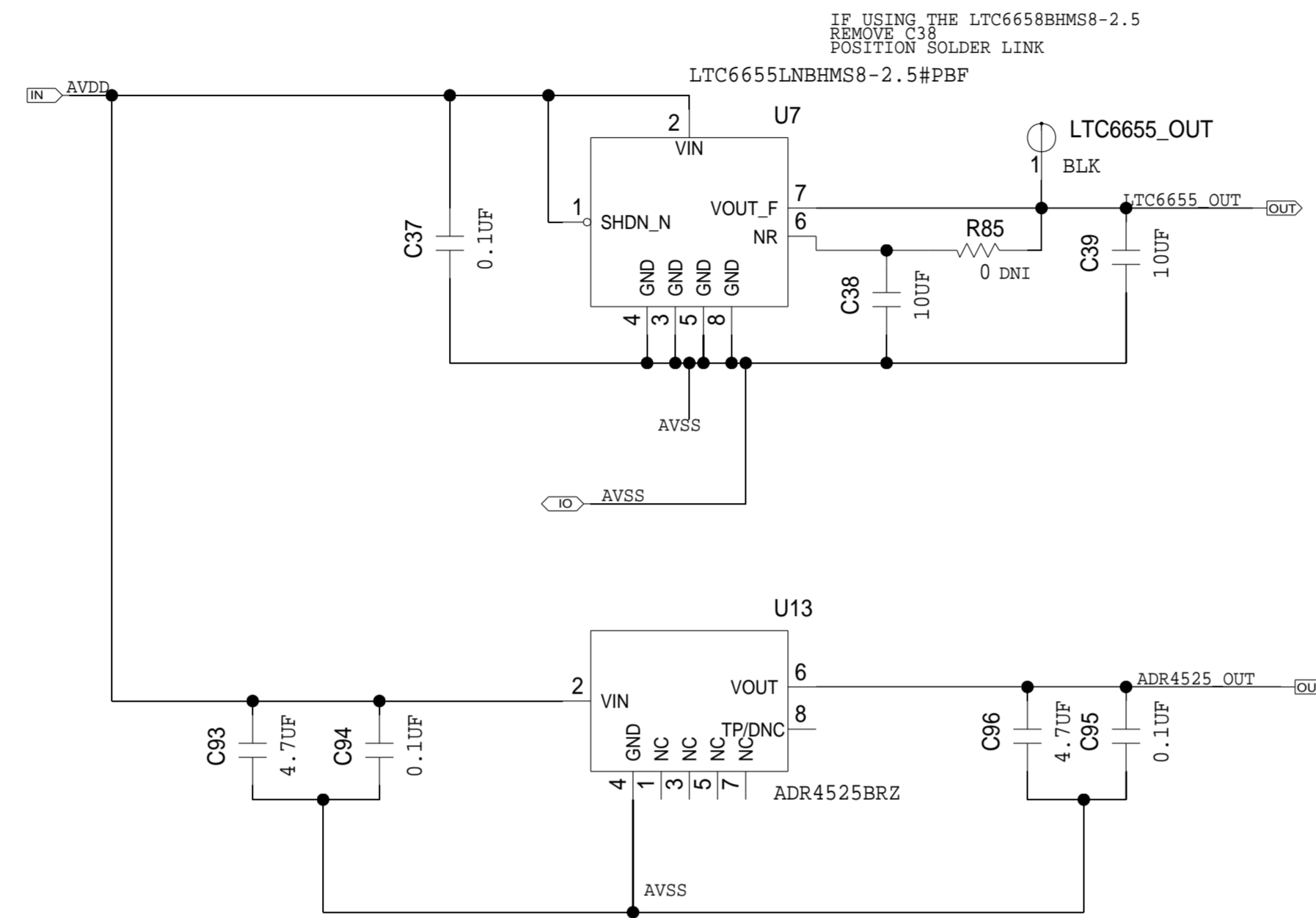

MOSFET STRUCTURE

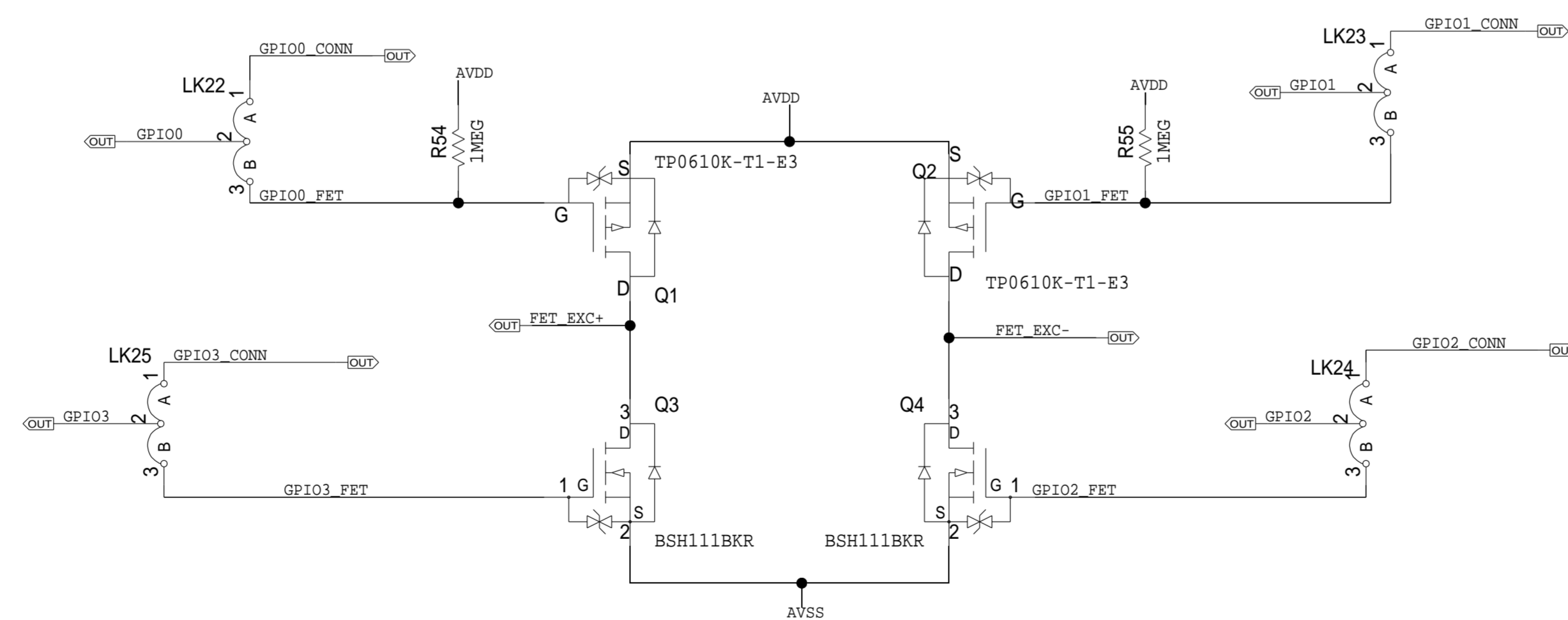

LK22/LK23/LK24/LK25
 POS A: TO CONNECTOR
 FOR USE AS GPIO/EXC CURR/PSM
 POS B: TO MOSFET STRUCTURE
 FOR USE AS AC EXCITATION TO J2 CONNECTOR, WIRE BRIDGE CIRCUIT

REVISIONS			
REV	DESCRIPTION	DATE	APPROVED

ANALOG DEVICES		SCHEMATIC	
HW TYPE: Customer Evaluation EVAL-AD7140-ASDZ : Currently N/A		DRAWING NO. 02-067069	REV E
DESIGN VIEW <DESIGN_VIEW>		SIZE D	SCALE 1:1
PTD ENGINEER SEAN CAHILL		SHEET 8	OF 8