

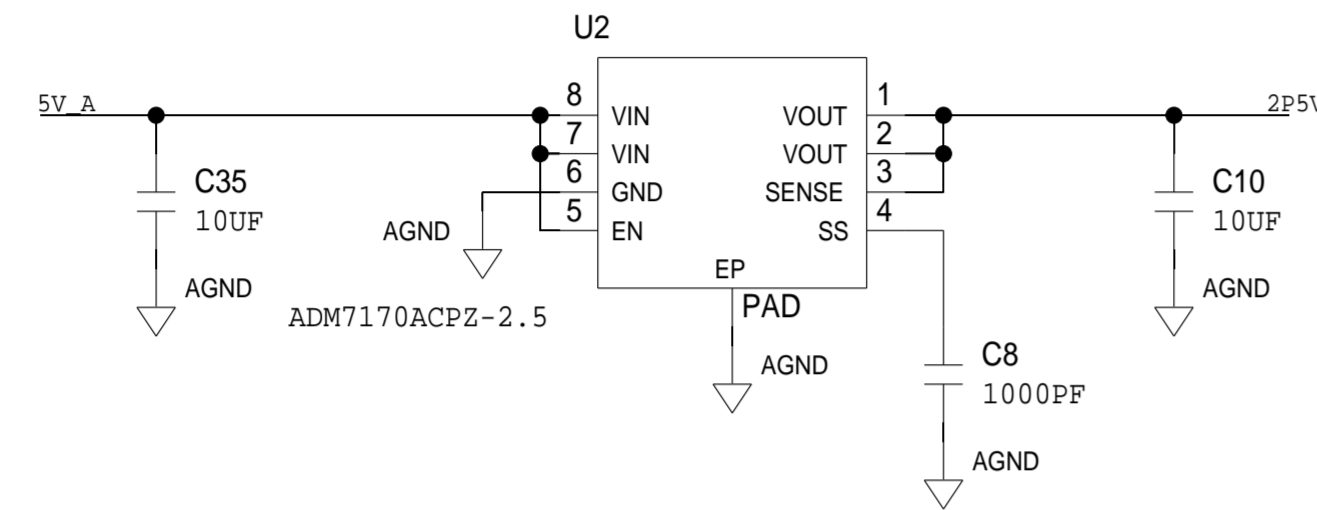

# SUPPLY CONNECTIONS

REVISIONS			
REV	DESCRIPTION	DATE	APPROVED

## 2.5V SUPPLY SELECTION



## 5V SUPPLY SELECTION

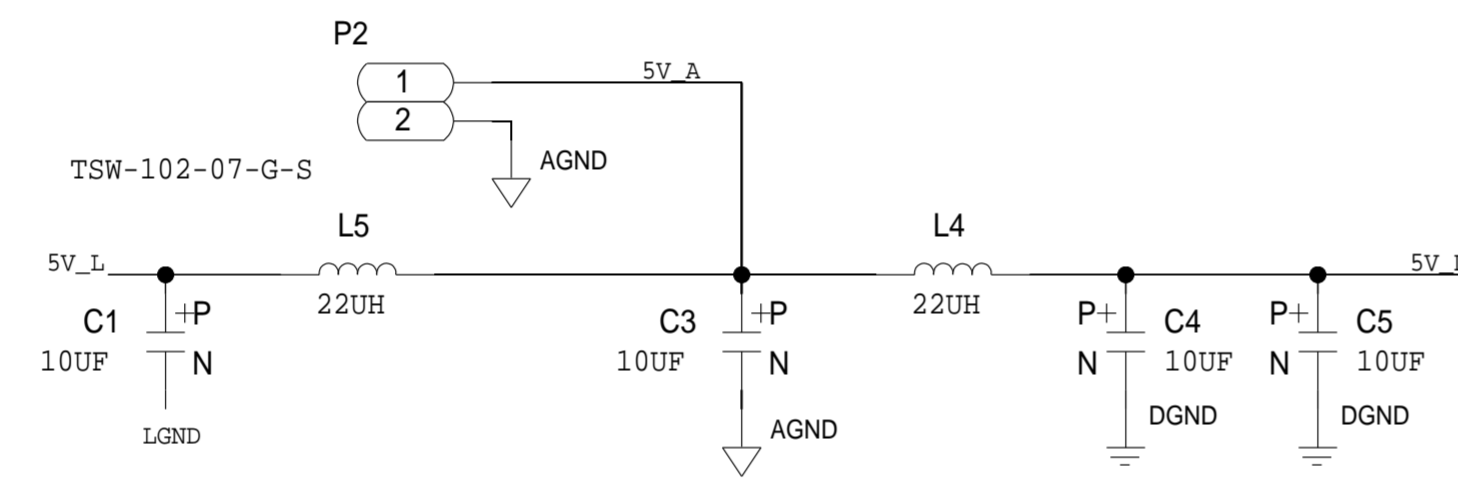

## 3.3V SUPPLY SELECTION

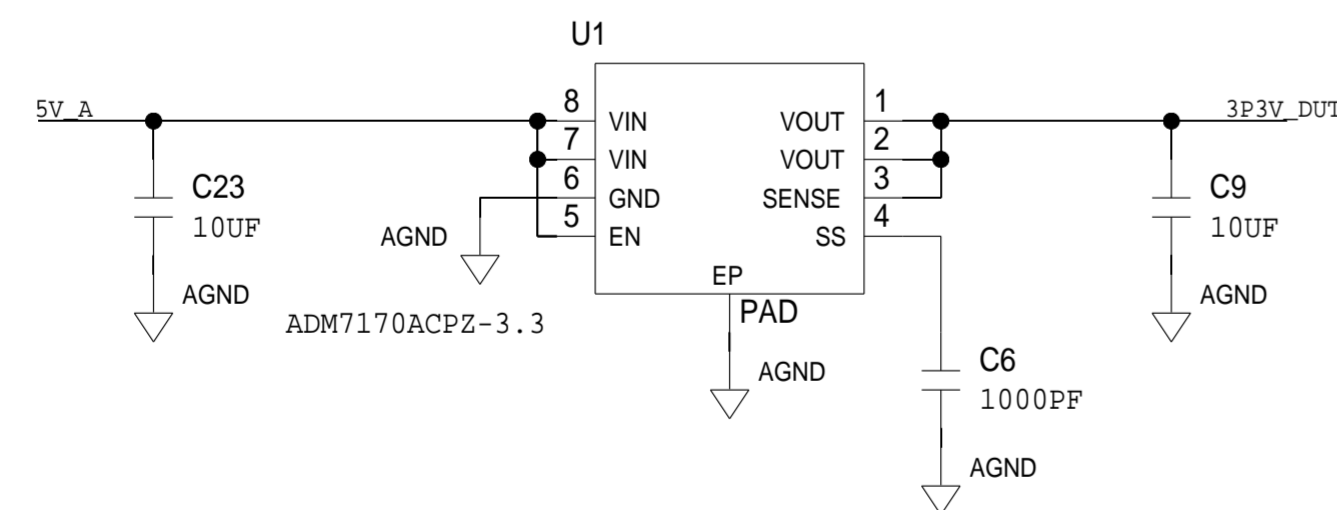

## APD BIAS SELECTION

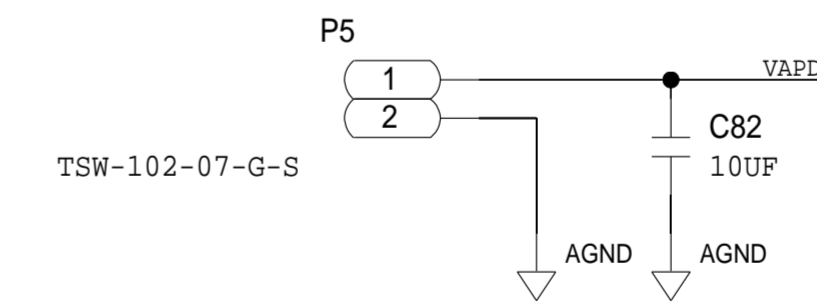

	<b>SCHEMATIC</b>		
	HW TYPE : Customer Evaluation Product(s): ADA4355 : ADA4355		
	DESIGN VIEW <DESIGN_VIEW>	DRAWING NO. 02_052057	REV D
	PTD ENGINEER Bruce Petipas	SIZE D	SCALE 1:1
		SHEET 2 OF 7	

REVISIONS			
REV	DESCRIPTION	DATE	APPROVED

# LDO & LEVEL SHIFTER FOR DUT SPI LINES

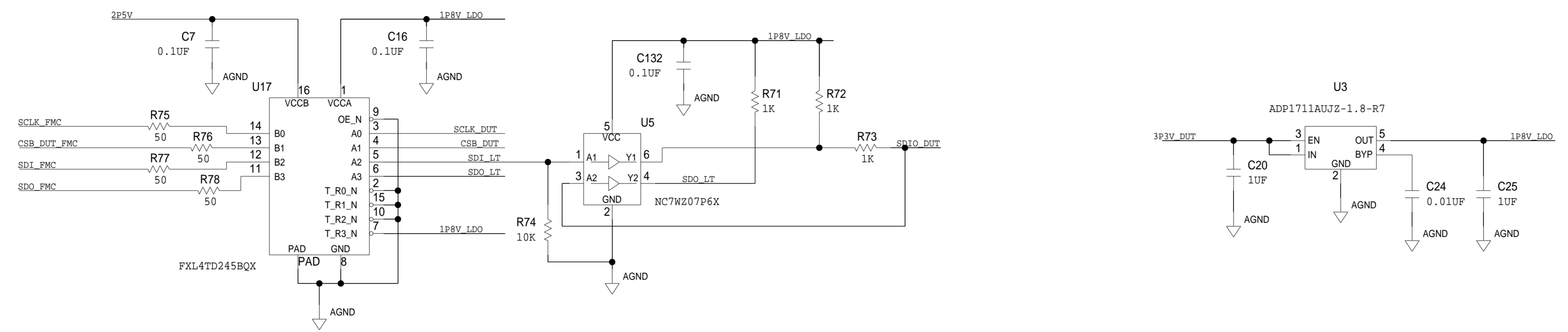

	<b>SCHEMATIC</b>		
	HW TYPE : Customer Evaluation Product(s): ADA4355 : ADA4355		
	DESIGN VIEW <DESIGN_VIEW>	DRAWING NO. 02_052057	REV D
	PTD ENGINEER Bruce Petipas	SIZE D	SCALE 1:1
		SHEET 3 OF 7	

# OSCAR DUT

PLACE ALL DECOUPLING CAPS ON BOTTOM OF BOARD AS CLOSE AS POSSIBLE TO DUT

REVISIONS			
REV	DESCRIPTION	DATE	APPROVED

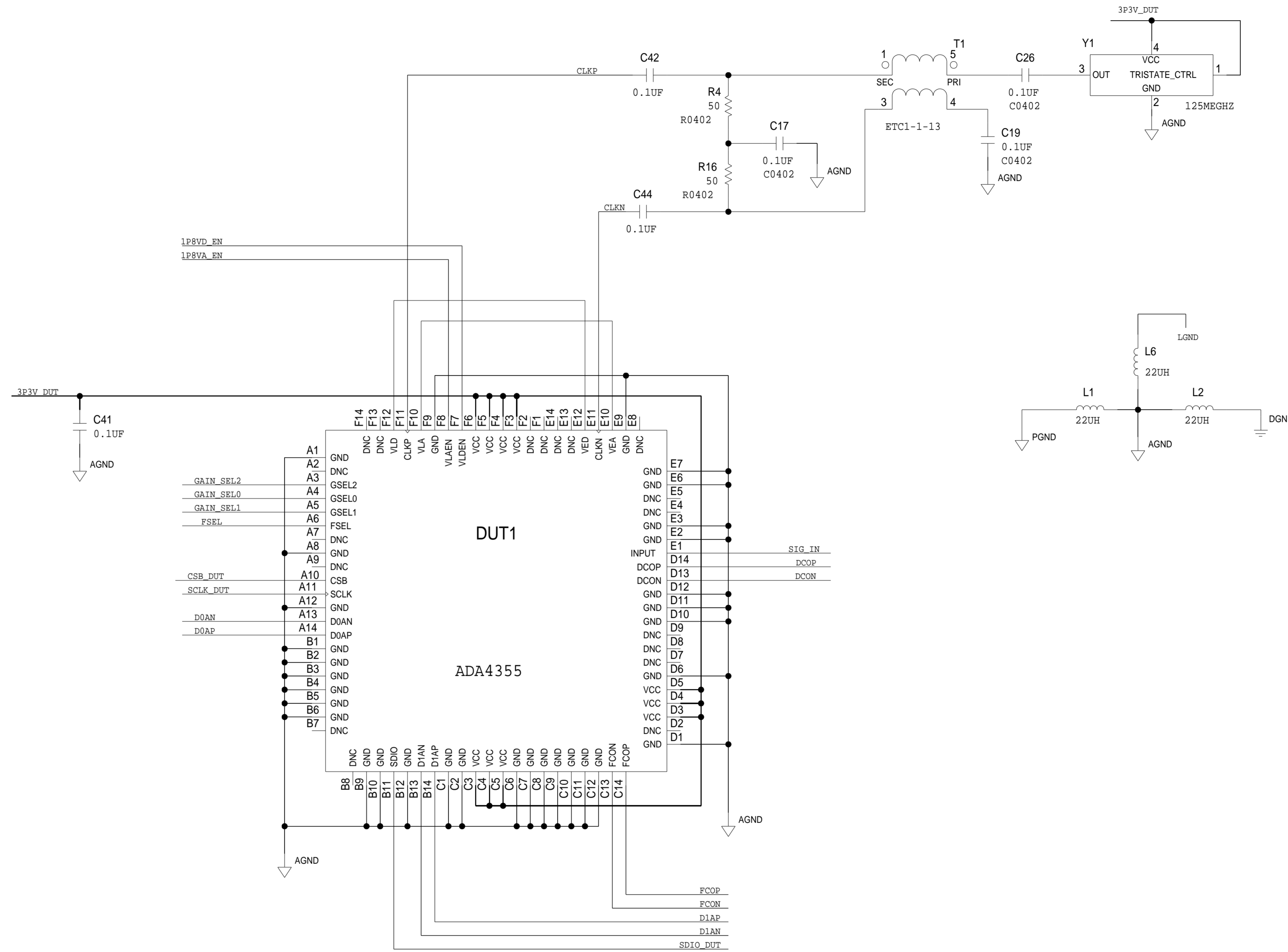

<p>THIS DRAWING IS THE PROPERTY OF ANALOG DEVICES INC. IT IS NOT TO BE REPRODUCED OR COPIED, IN WHOLE OR IN PART, OR USED FOR ANY OTHER PURPOSES INFORMATIONAL TO OTHERS, OR FOR ANALOG DEVICES. THE EQUIPMENT SHOWN HEREIN MAY BE PROTECTED BY PATENTS OWNED OR CONTROLLED BY ANALOG DEVICES.</p>	<b>SCHEMATIC</b>		
	HW TYPE : Customer Evaluation Product(s): ADA4355 : ADA4355		
	DESIGN VIEW <DESIGN_VIEW>	DRAWING NO. 02_052057	REV D
	PTD ENGINEER Bruce Petipas	SIZE D	SCALE 1:1

REVISIONS			
REV	DESCRIPTION	DATE	APPROVED

# LASER DRIVER CIRCUIT

PLACE ALL DECOUPLING CAPS AS CLOSE AS POSSIBLE TO THEIR RESPECTIVE IC

## DIGITAL LASER POWER TRIM

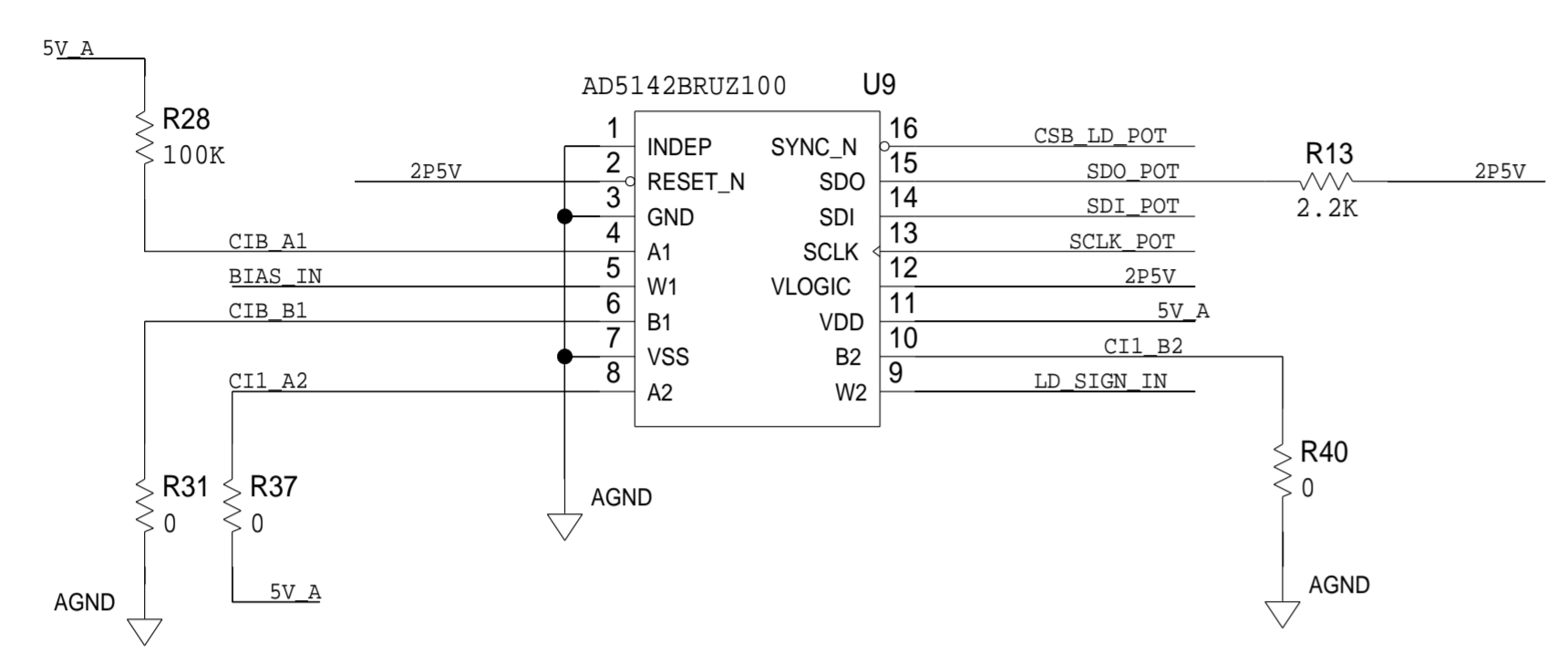

PLACE THESE CAPS AS CLOSE TO U9 AS POSSIBLE

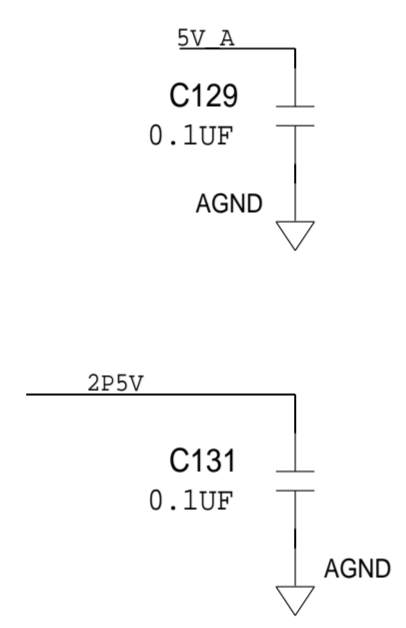

## LASER DIODE

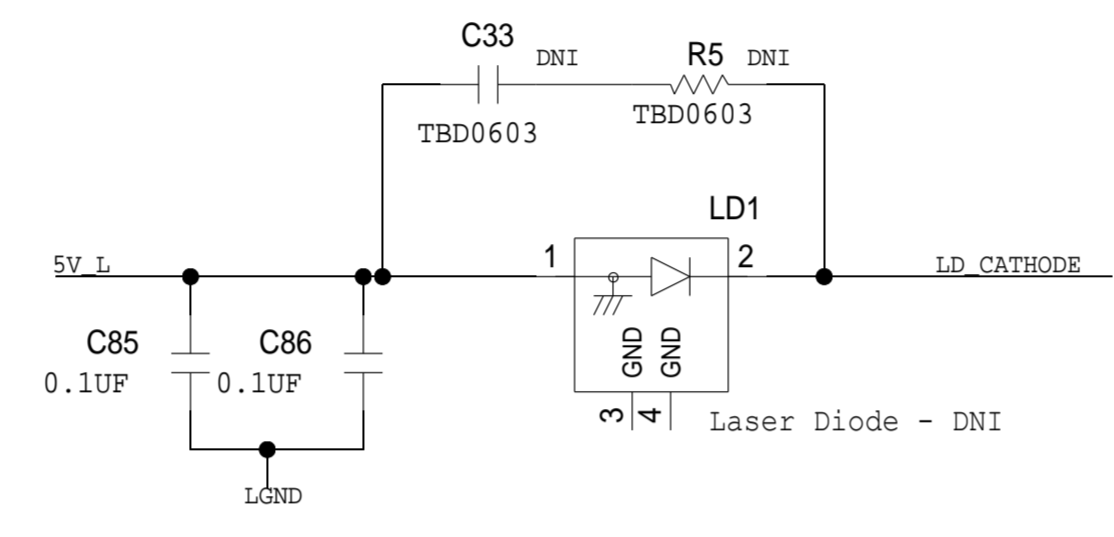

## LASER DIODE DRIVER

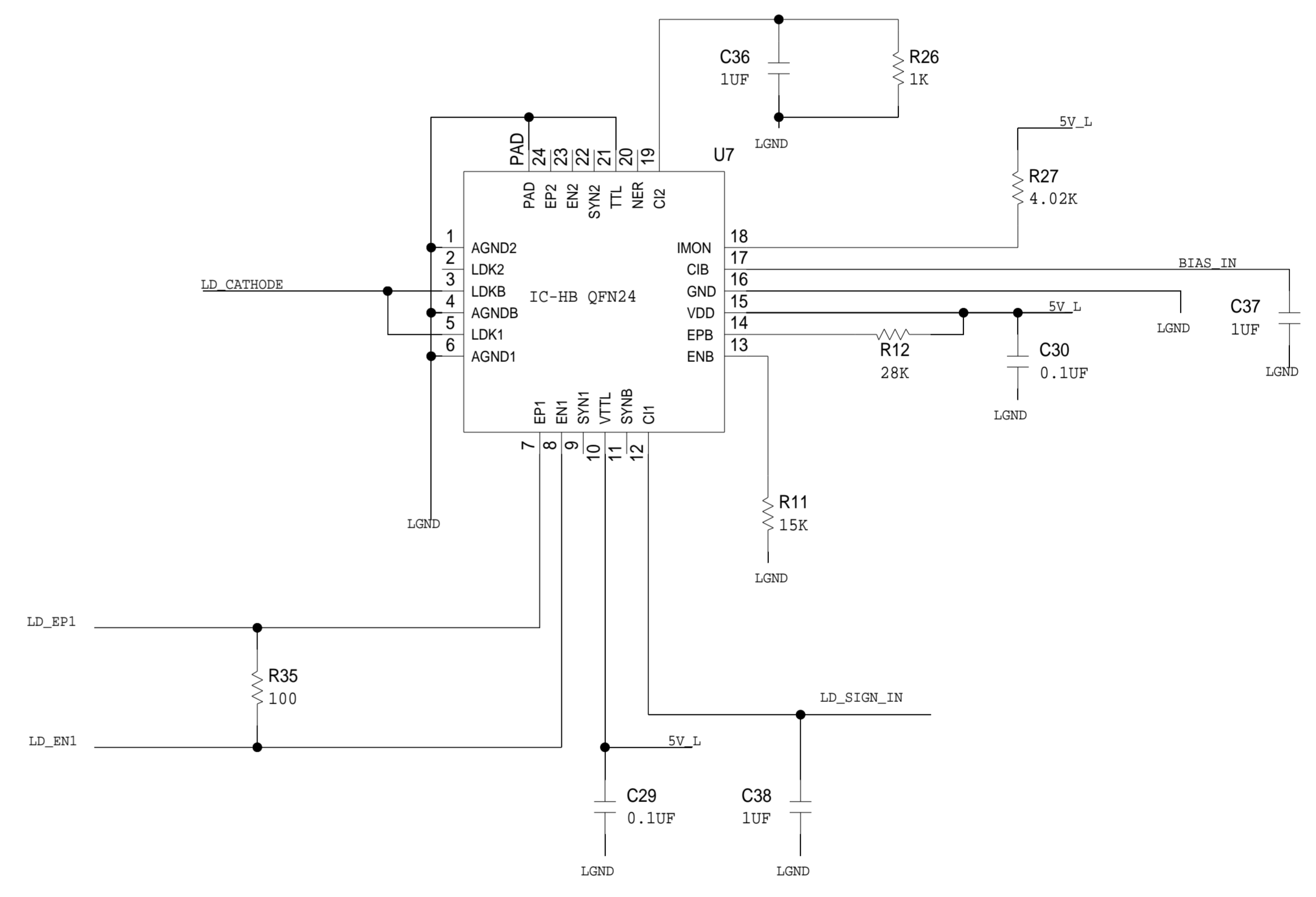

	<b>SCHEMATIC</b>		
	HW TYPE : Customer Evaluation Product(s) : ADA4355 : ADA4355		
	DESIGN VIEW <DESIGN_VIEW>	DRAWING NO. 02_052057	REV D
	PTD ENGINEER Bruce Petipas	SIZE D	SCALE 1:1
		SHEET 5 OF 7	

REVISIONS			
REV	DESCRIPTION	DATE	APPROVED

# APD VOLTAGE GENERATOR

## APD POWER SUPPLY

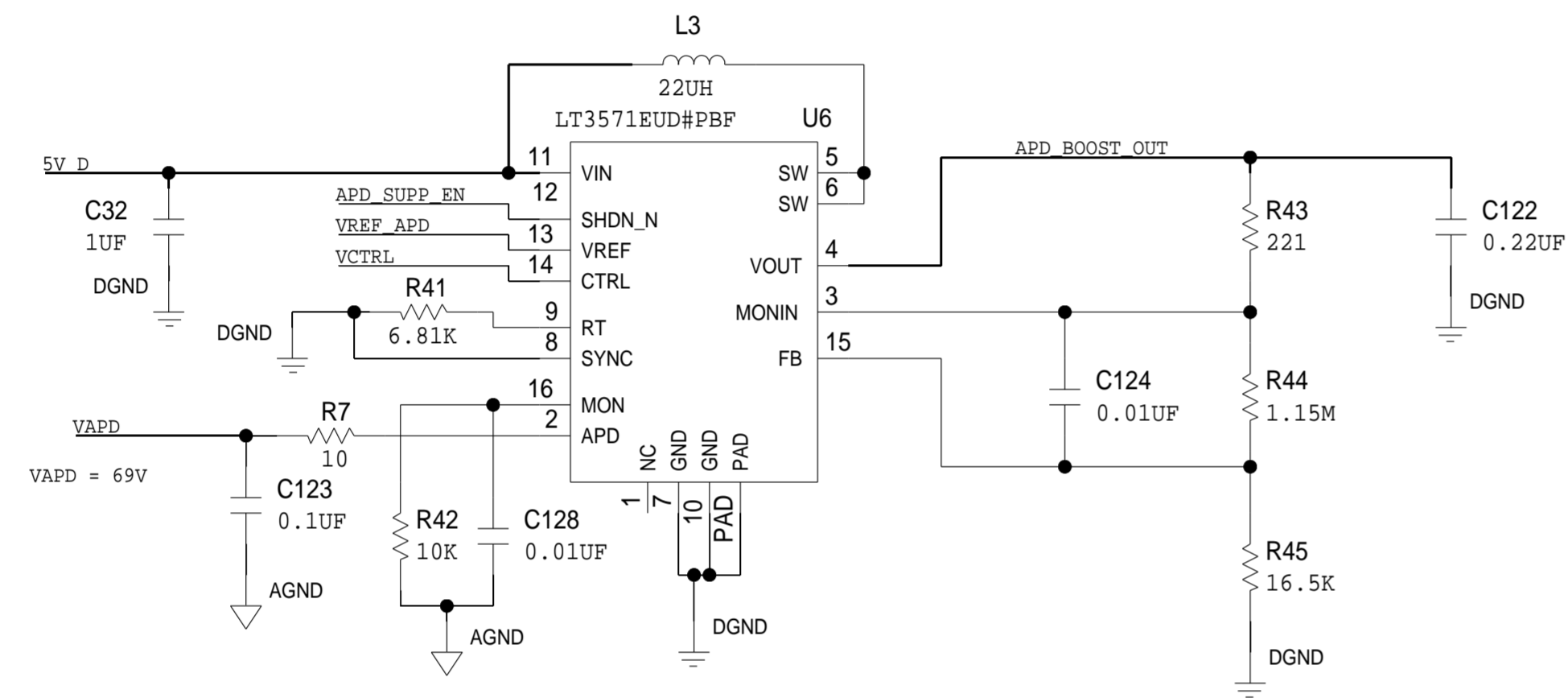

## DIGITAL APD VOLTAGE ADJUST

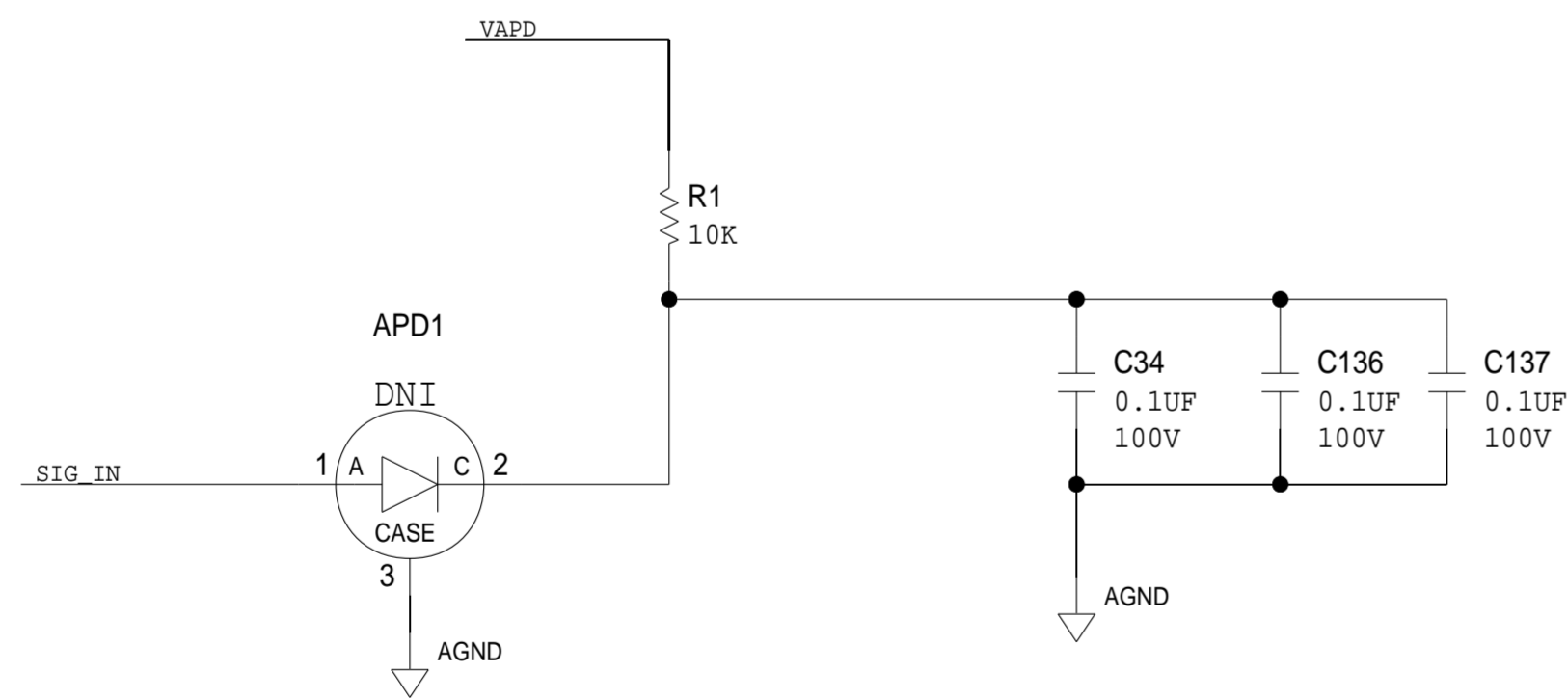
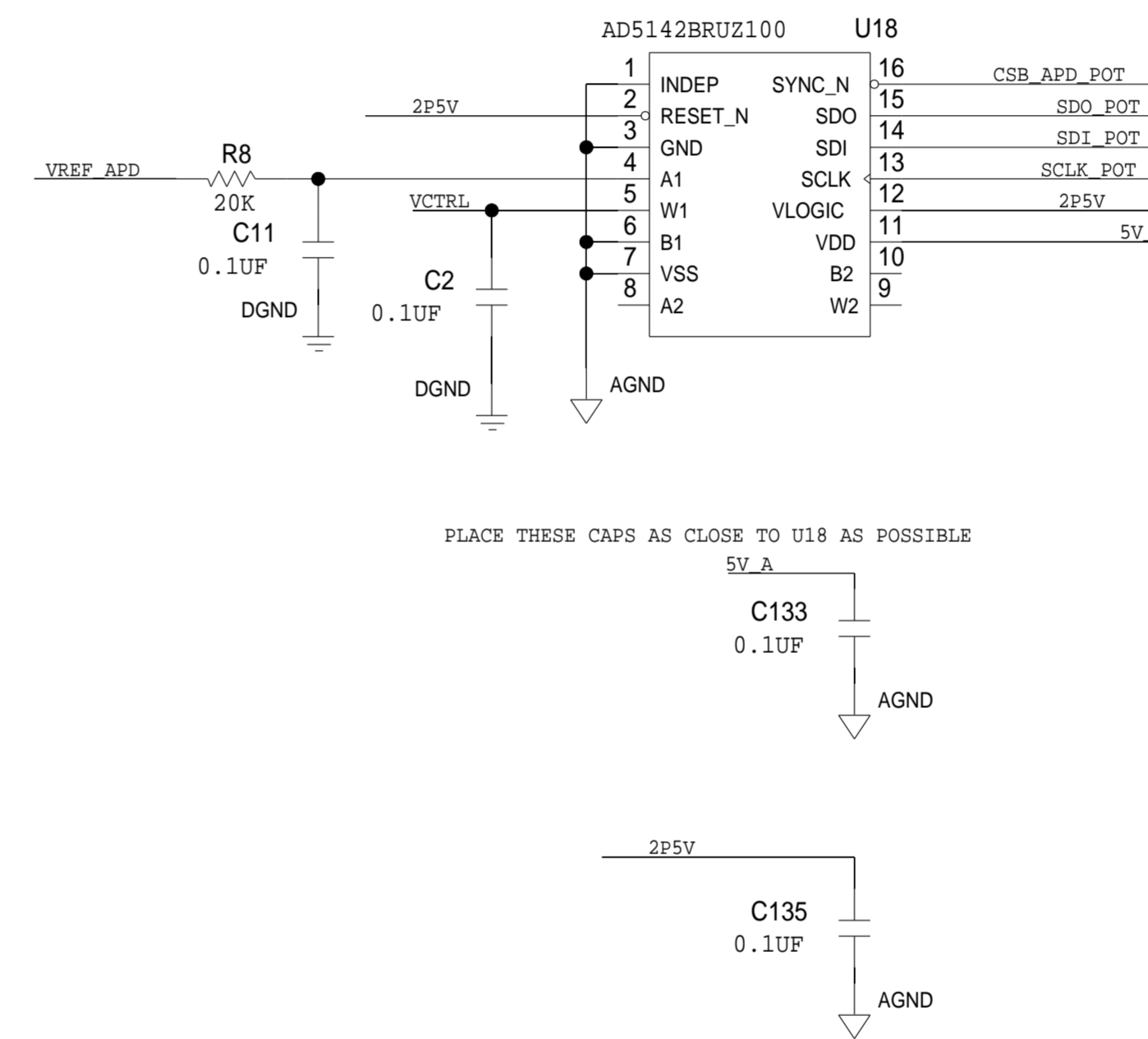

\*\*PLACE APD AS CLOSE TO DUT AS POSSIBLE\*\*

ANALOG DEVICES				SCHEMATIC			
<small>THIS DRAWING IS THE PROPERTY OF ANALOG DEVICES, INC. IT IS NOT TO BE REPRODUCED OR COPIED, IN WHOLE OR IN PART, OR USED IN FURNISHING INFORMATION TO OTHERS, OR FOR ANY OTHER PURPOSE DETRIMENTAL TO THE INTERESTS OF ANALOG DEVICES. THE EQUIPMENT SHOWN HEREON MAY BE PROTECTED BY PATENTS OWNED OR CONTROLLED BY ANALOG DEVICES.</small>				HW TYPE : Customer Evaluation		DRAWING NO. 02_052057	
				Product(s): ADA4355		REV D	
DESIGN VIEW <DESIGN_VIEW>		PTD ENGINEER Bruce Petipas		SIZE D		SCALE 1:1	
				SHEET 6		OF 7	

# FMC CONNECTIONS

REVISIONS			
REV	DESCRIPTION	DATE	APPROVED

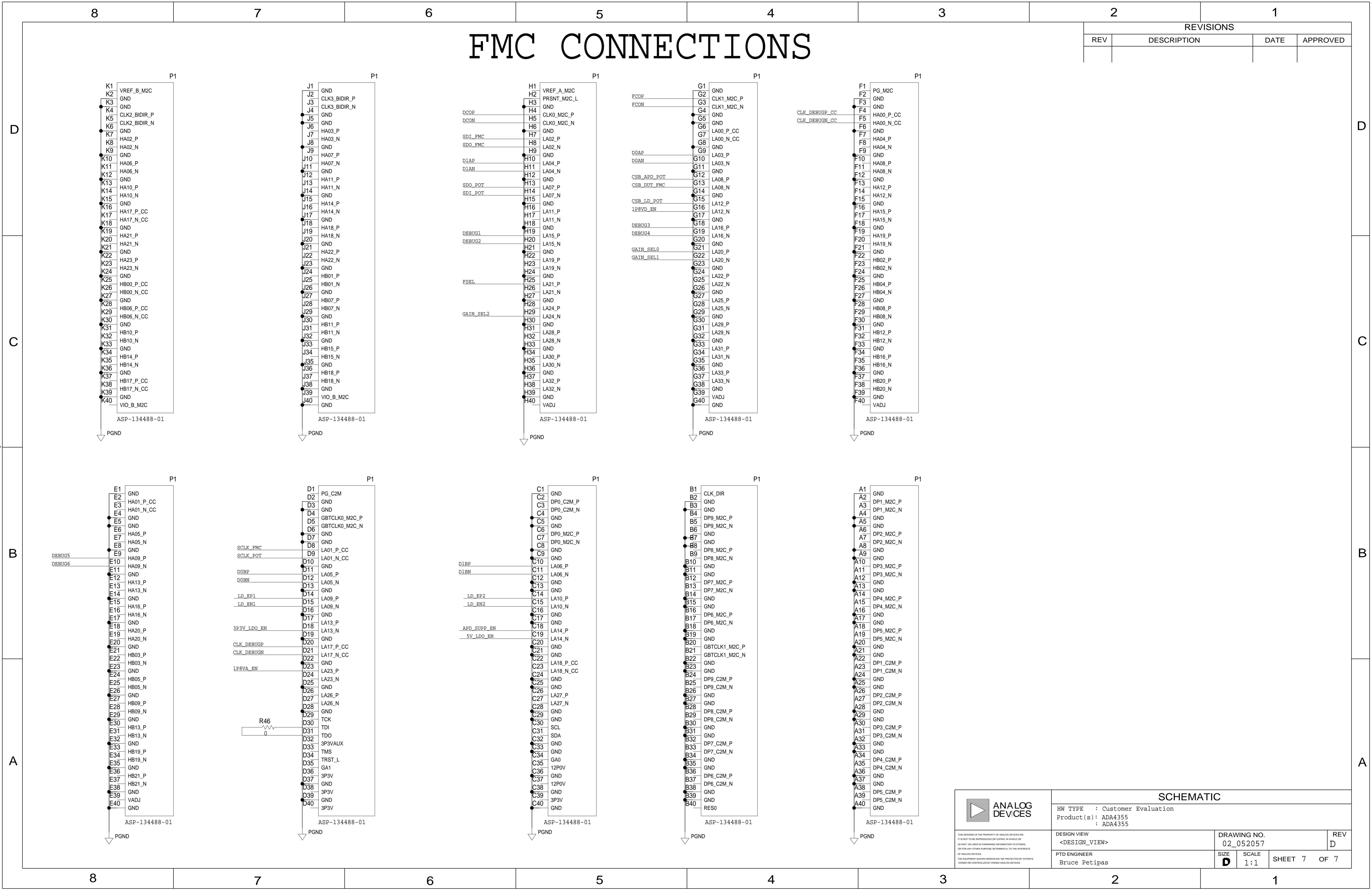

SCHEMATIC			
		HW TYPE : Customer Evaluation Product(s) : ADA4355 : ADA4355	
DESIGN VIEW <DESIGN_VIEW>	DRAWING NO. 02_052057	REV D	
PTD ENGINEER Bruce Petipas	SIZE D	SCALE 1:1	SHEET 7 OF 7