

REVISIONS			
REV	DESCRIPTION	DATE	APPROVED

AD9684 DUT

DECOUPLING CAPACITORS

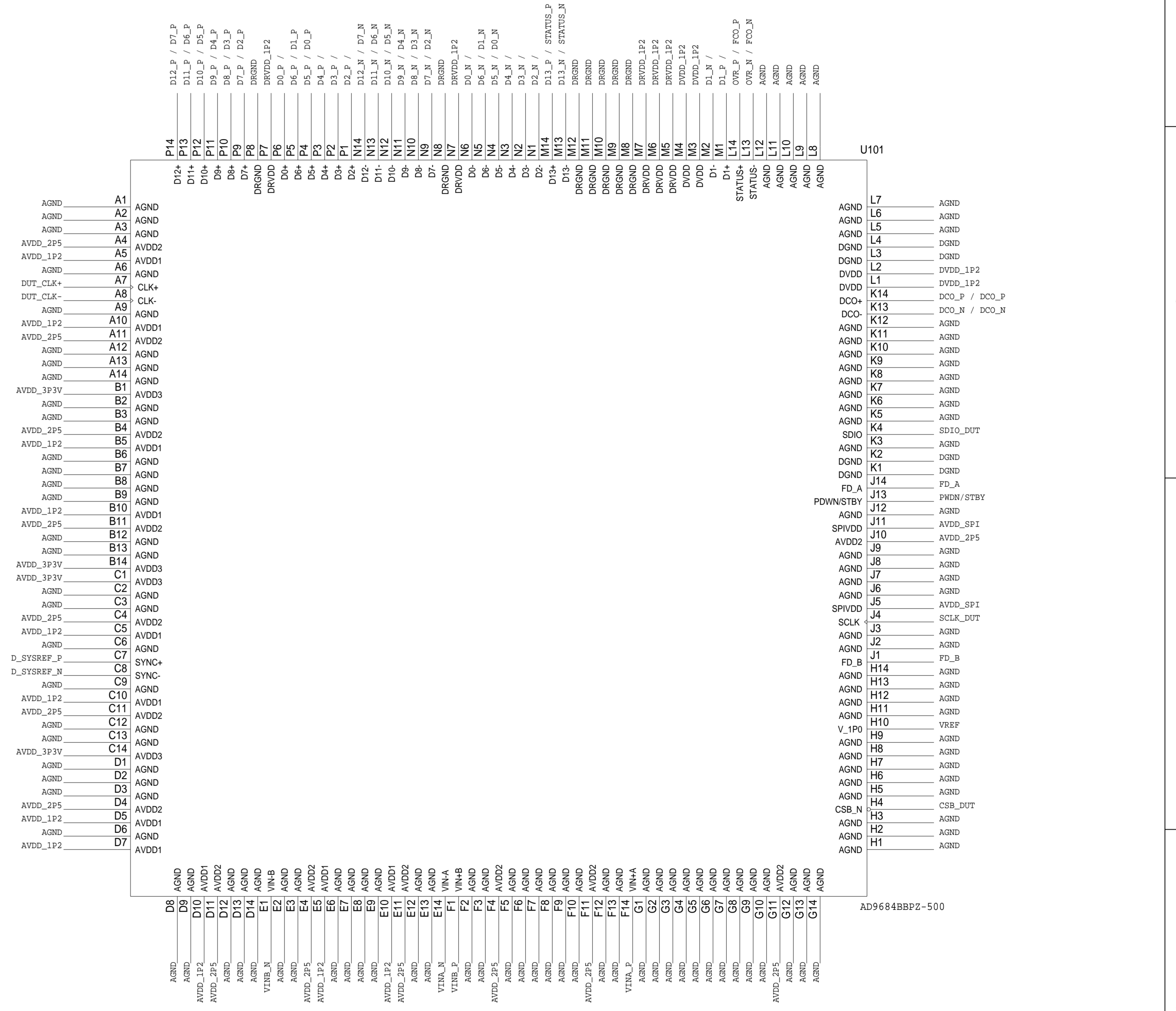
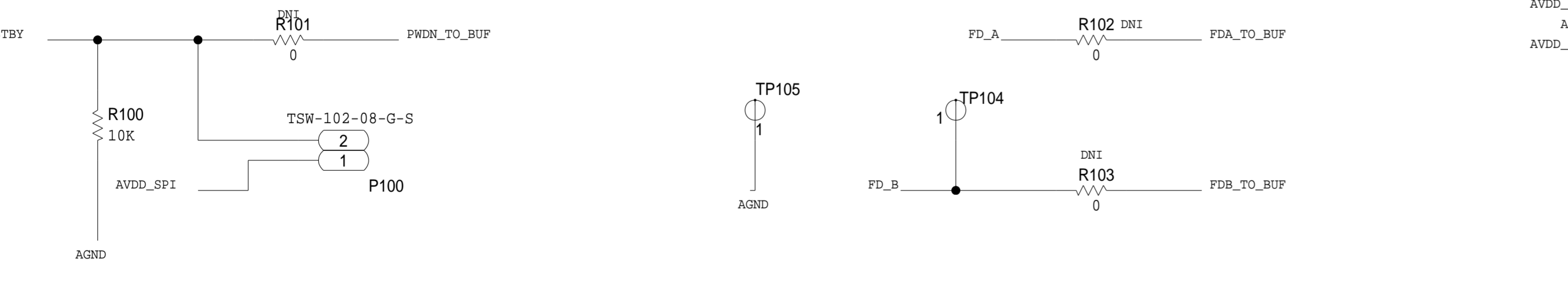
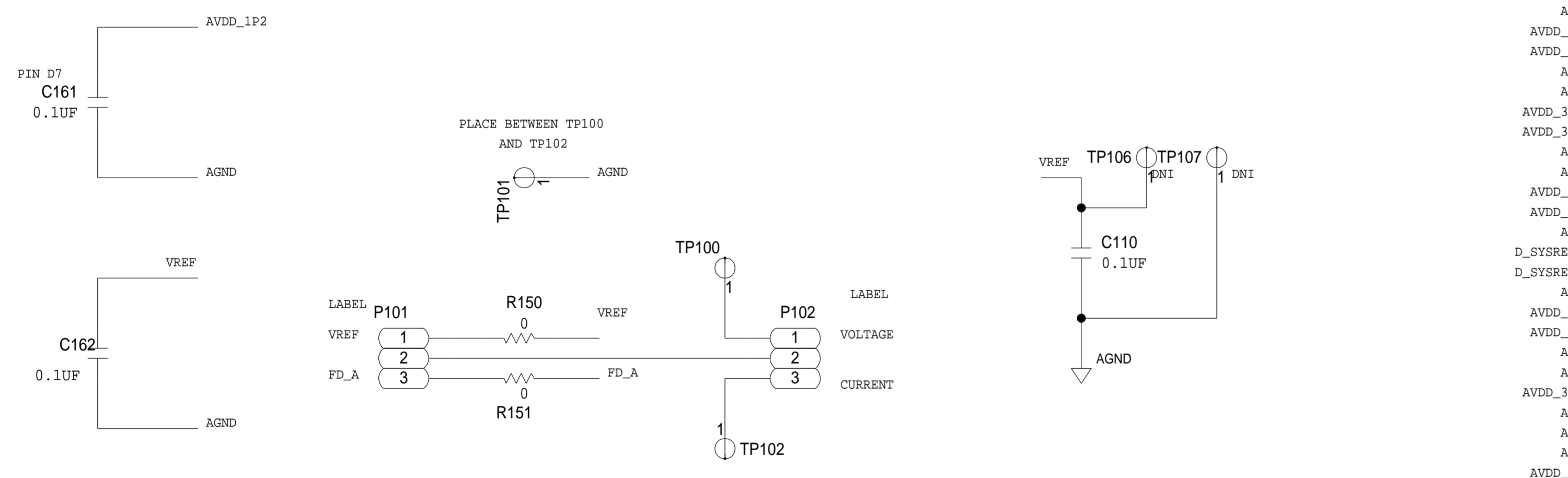
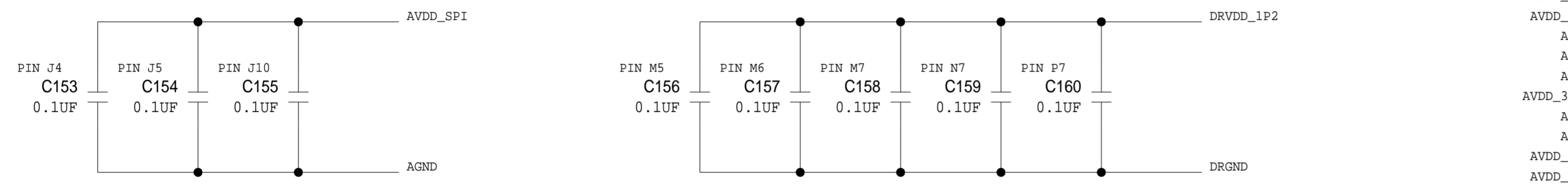
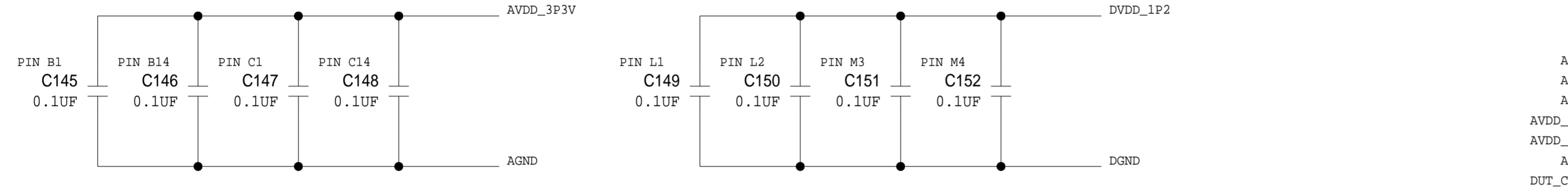
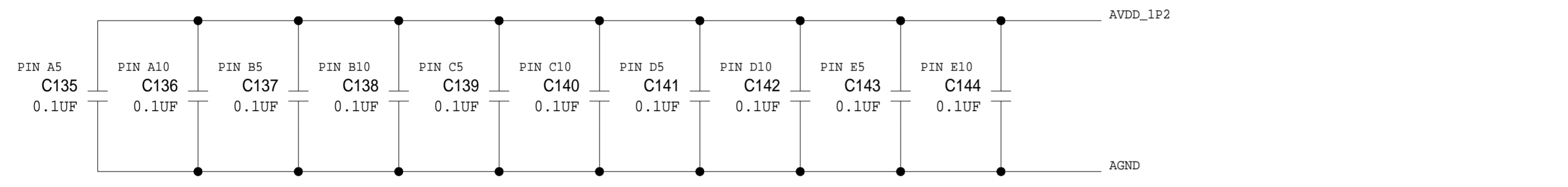
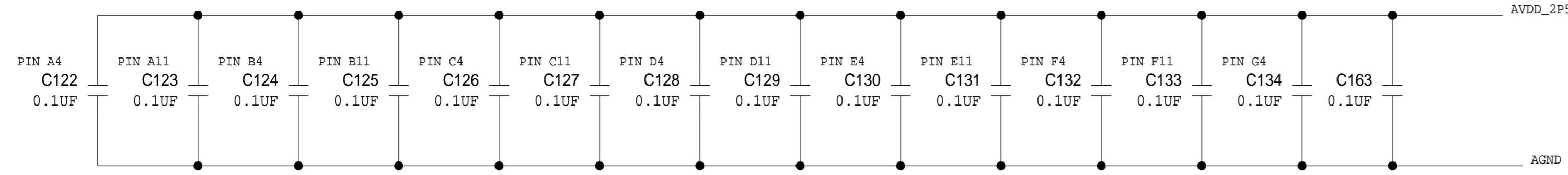

SCHEMATIC			
		HW TYPE : Customer Evaluation Product(s) : AD9684 AD9684-500EBZ	
DESIGN VIEW	-	DRAWING NO.	02_040108
PT ENGINEER	IAN BEAVERS	SCALE	1:1
REV	A2	SHEET	1 OF 6

THIS DRAWING IS THE PROPERTY OF ANALOG DEVICES INC. IT IS NOT TO BE REPRODUCED OR COPIED IN WHOLE OR IN PART, OR USED IN FURNISHING INFORMATION TO OTHERS, OR FOR ANY OTHER PURPOSE DETRIMENTAL TO THE INTERESTS OF ANALOG DEVICES. THE EQUIPMENT SHOWN HEREON MAY BE PROTECTED BY PATENTS OWNED OR CONTROLLED BY ANALOG DEVICES.

REVISIONS			
REV	DESCRIPTION	DATE	APPROVED

ANALOG INPUT A

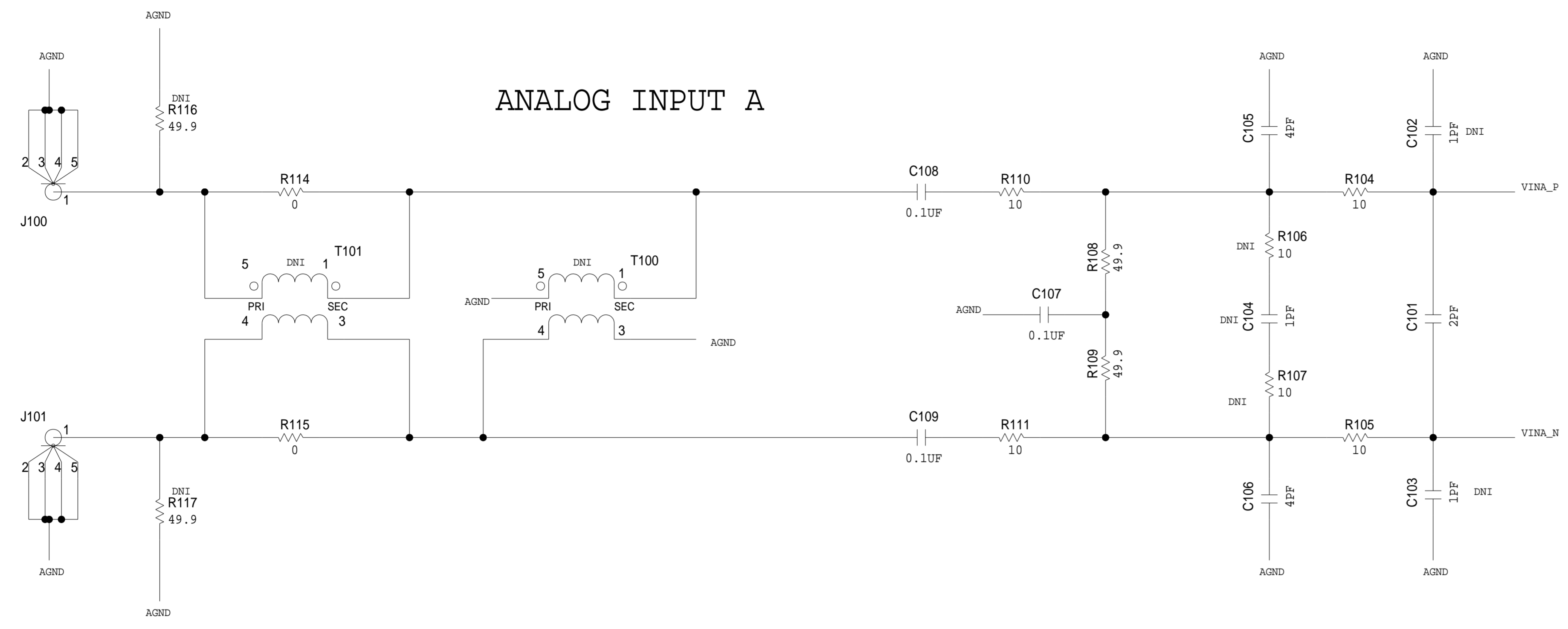

PLACE 10 OHM SERIES R. CLOSE TO DIFF. C AND CLOSE TO DUT

ANALOG INPUT B

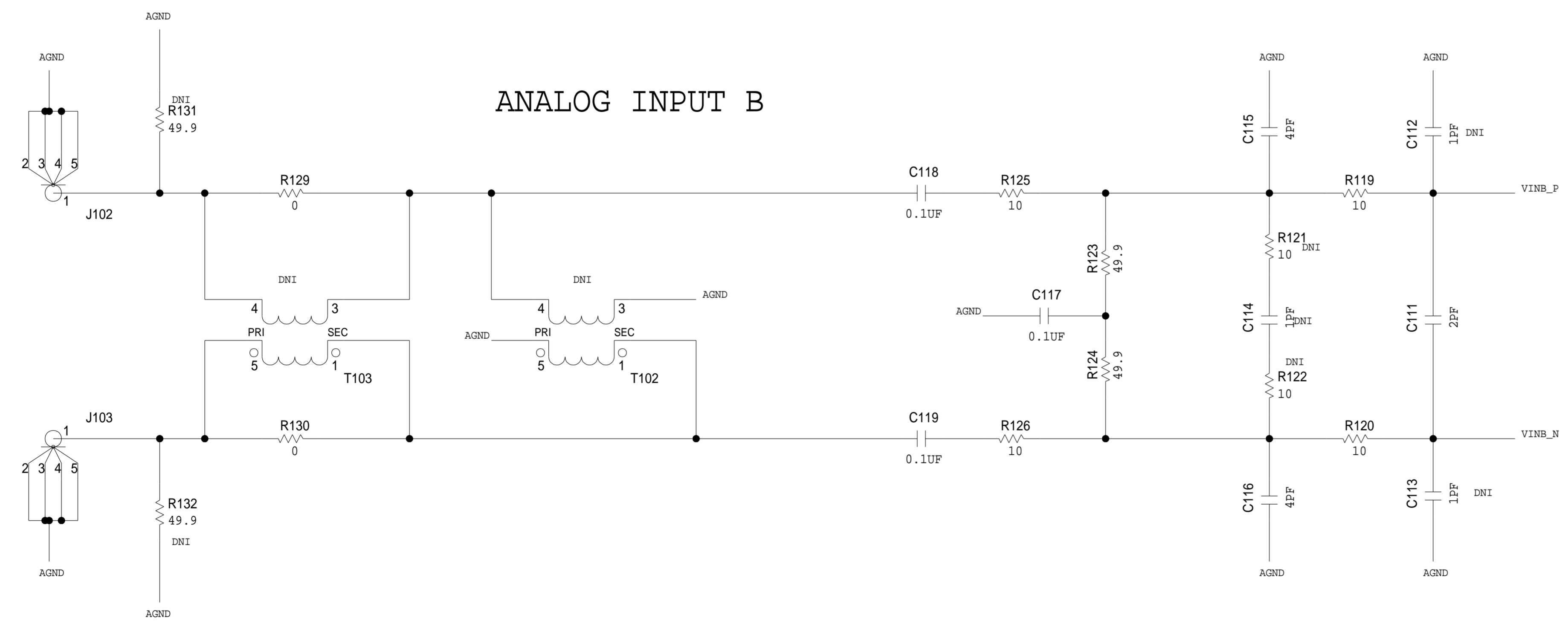

PLACE 10 OHM SERIES R. CLOSE TO DIFF. C AND CLOSE TO DUT

	SCHEMATIC		
	HW TYPE : Customer Evaluation Product(s) : AD9684 AD9684-500EBZ		
	DESIGN VIEW -	DRAWING NO. 02_040108	REV A2
PTD ENGINEER IAN BEAVERS	SIZE D	SCALE 1:1	SHEET 2 OF 6

AD9684 CLOCK INPUTS

PLACE ON BOTTOM OF BOARD

REVISIONS			
REV	DESCRIPTION	DATE	APPROVED

OPTIONAL OSCILLATOR

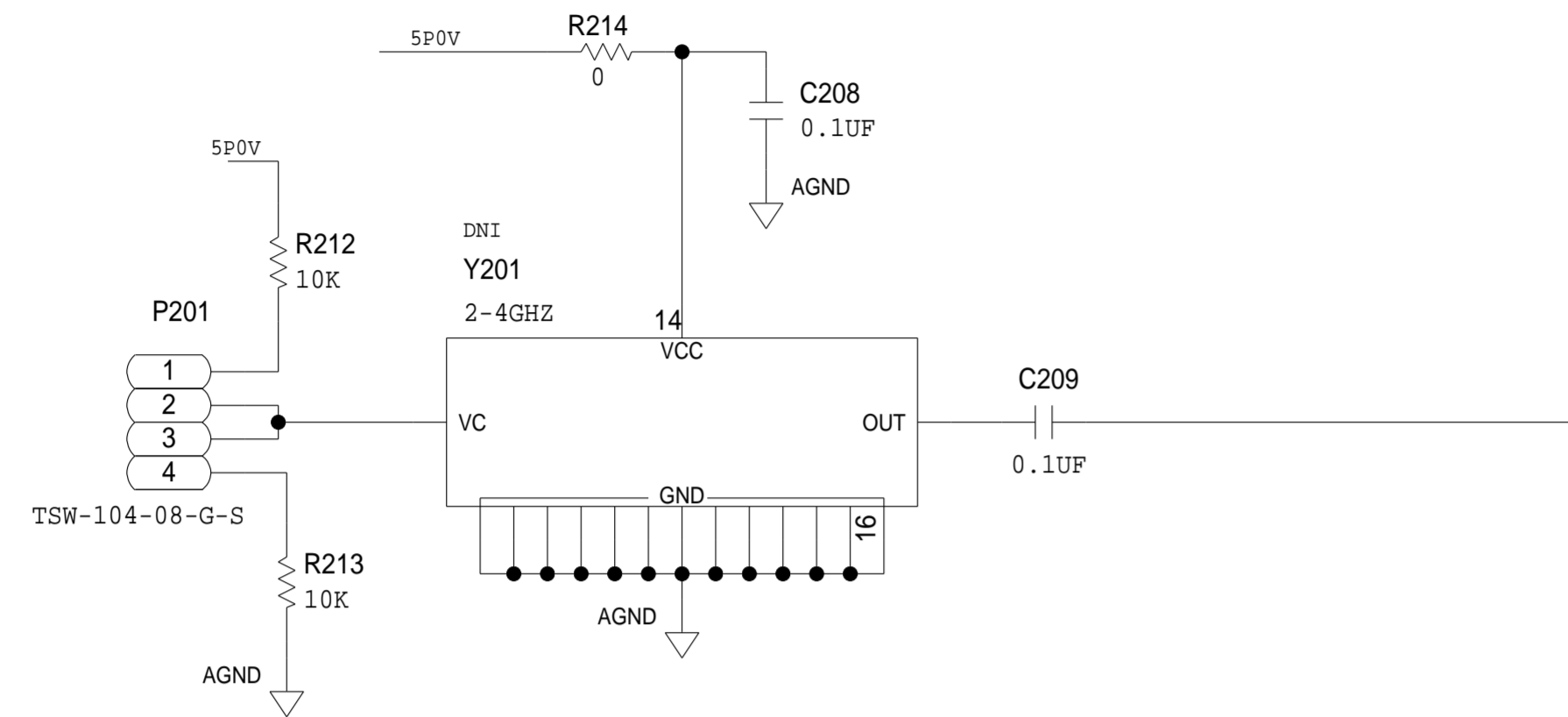

ENCODE/CLOCK INPUT

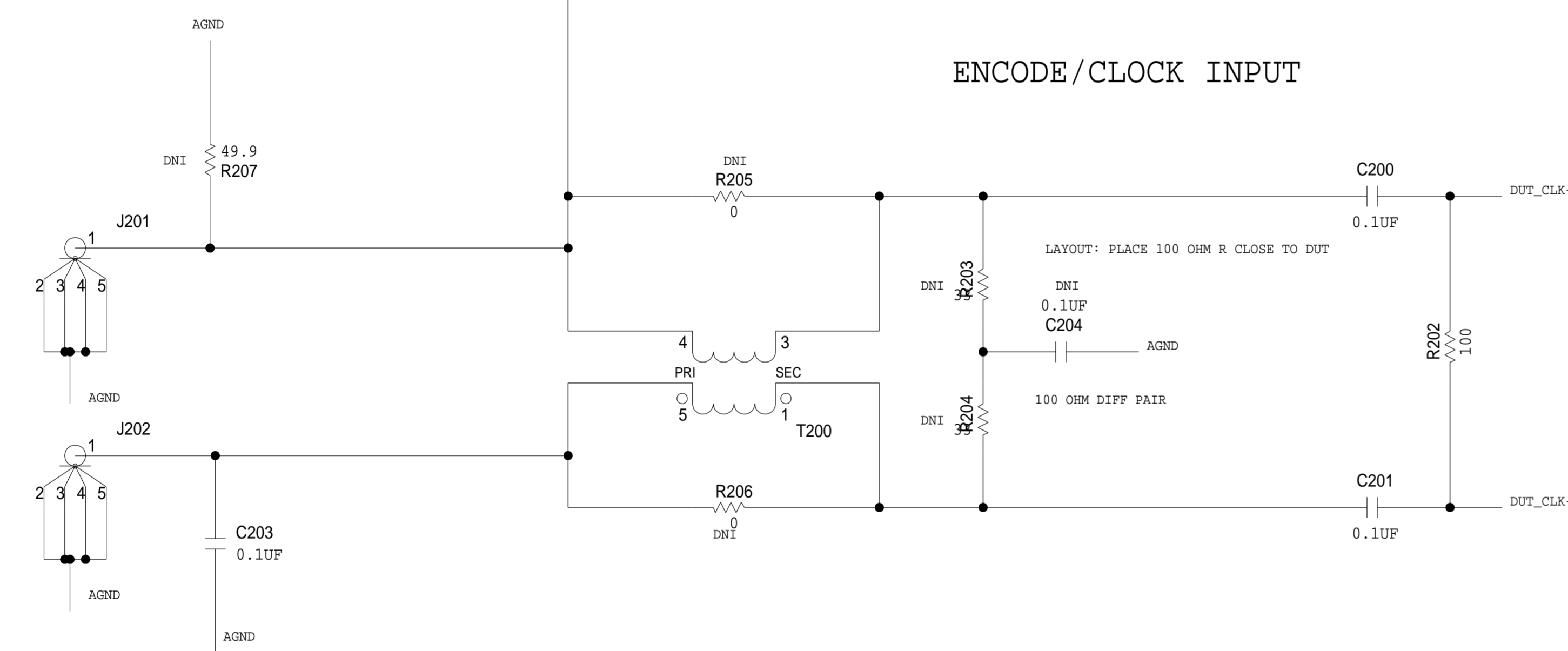

EXTERNAL SYSREF TO DUT

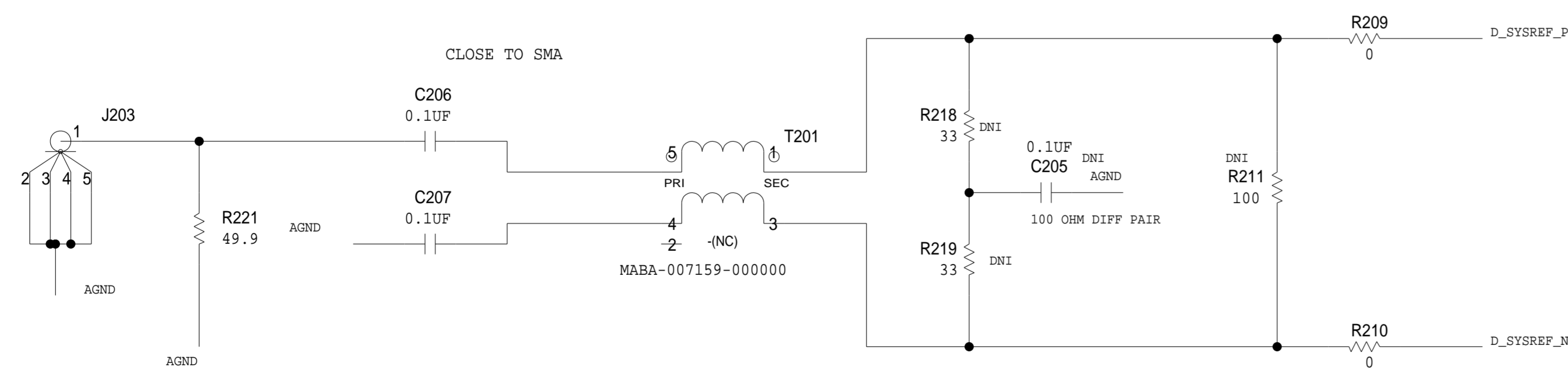

EEPROM - BOARD ID

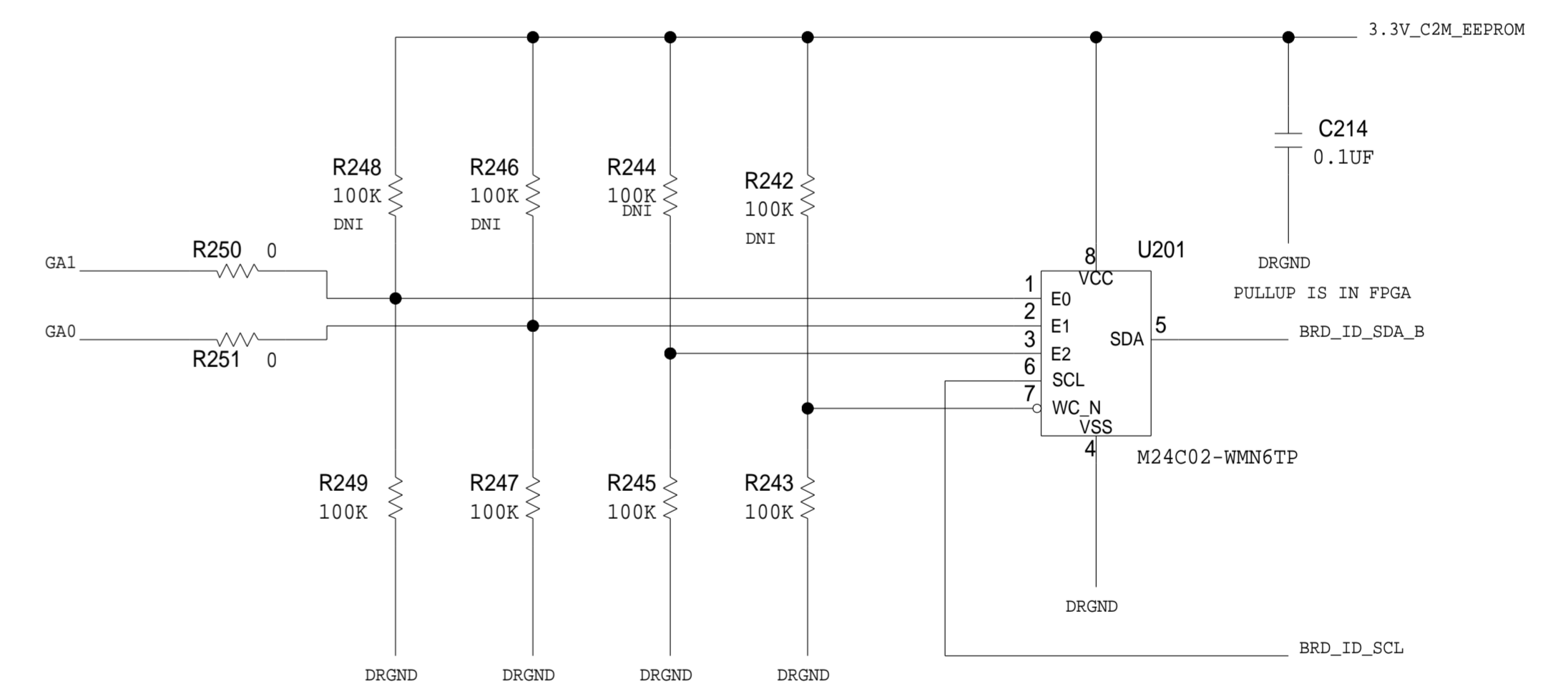

ANALOG DEVICES		SCHEMATIC			
<small>THIS DRAWING IS THE PROPERTY OF ANALOG DEVICES INC. IT IS NOT TO BE REPRODUCED OR COPIED, IN WHOLE OR IN PART, OR USED IN FURNISHING INFORMATION TO OTHERS, OR FOR ANY OTHER PURPOSE DETRIMENTAL TO THE INTERESTS OF ANALOG DEVICES. THE EQUIPMENT SHOWN HEREON MAY BE PROTECTED BY PATENTS OWNED OR CONTROLLED BY ANALOG DEVICES.</small>		HW TYPE : Customer Evaluation		DRAWING NO. 02_040108	
		Product(s) : AD9684 AD9684-500EBZ		REV A2	
DESIGN VIEW -		SIZE D	SCALE 1:1	SHEET 3 OF 6	
PTD ENGINEER IAN BEAVERS					

POWER SUPPLIES

REVISIONS			
REV	DESCRIPTION	DATE	APPROVED

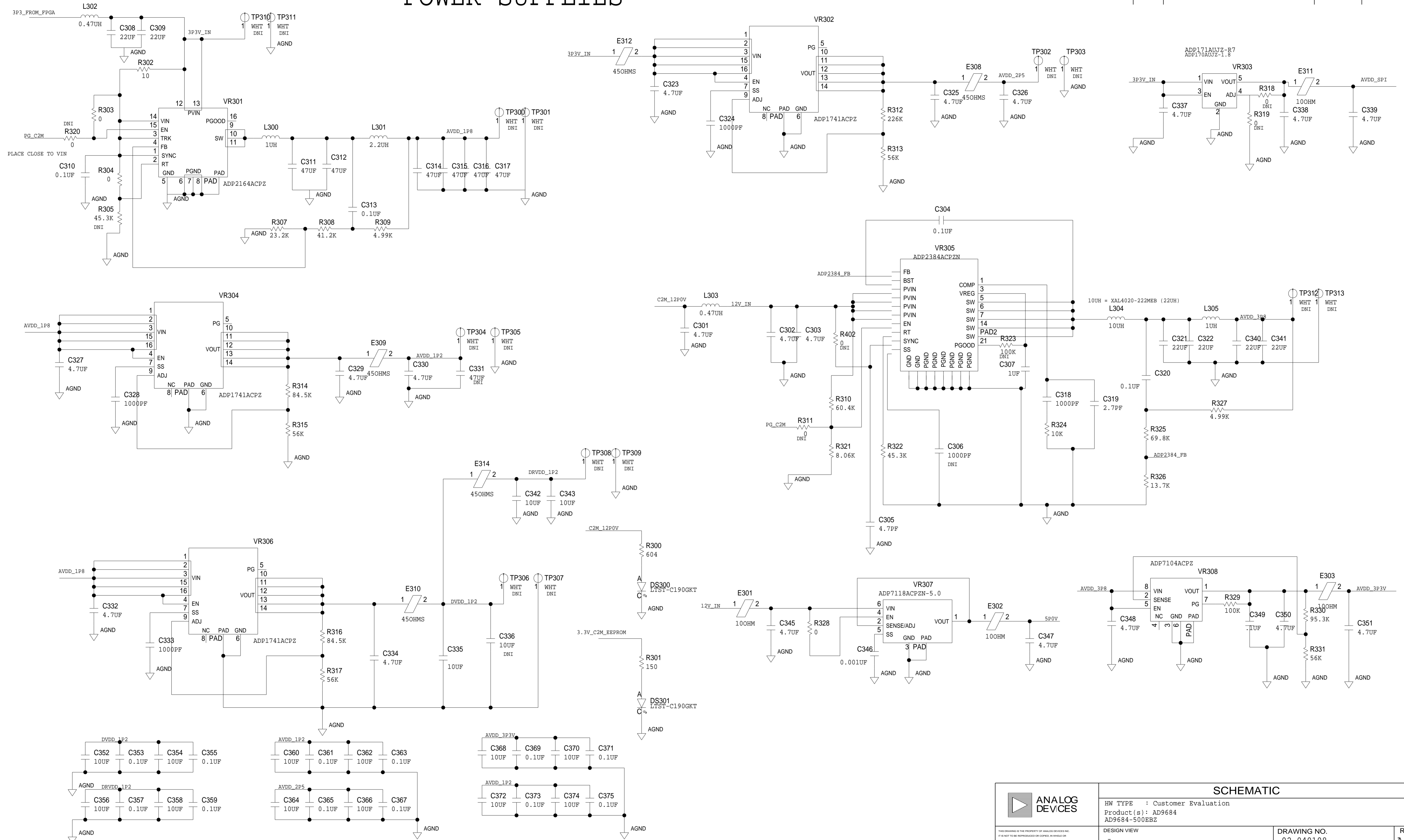

	SCHEMATIC		
	HW TYPE : Customer Evaluation		
	Product(s) : AD9684 AD9684-500EBZ		
	DESIGN VIEW	DRAWING NO.	REV
-	02_040108	A2	
PTD ENGINEER	SIZE	SCALE	SHEET 4 OF 6
IAN BEAVERS	D	1:1	

REVISIONS			
REV	DESCRIPTION	DATE	APPROVED

SPI / BUFFER CIRCUIT

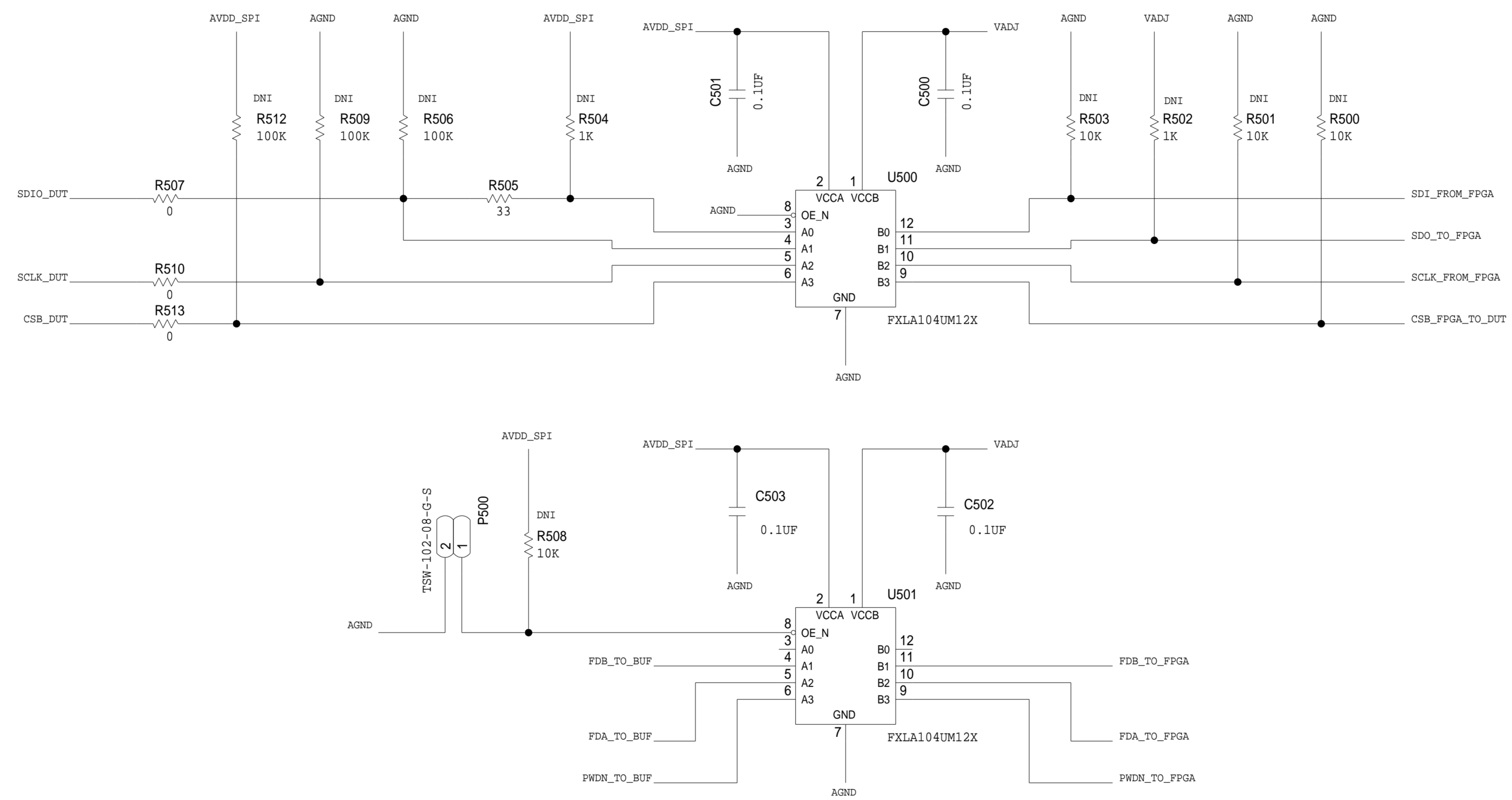

	SCHEMATIC		
	HW TYPE : Customer Evaluation Product(s) : AD9684 AD9684-500EBZ		
	DESIGN VIEW	DRAWING NO.	REV
	-	02_040108	A2
PTD ENGINEER	SIZE	SCALE	SHEET 5 OF 6
IAN BEAVERS	D	1:1	

AD9684 FMC CONNECTIONS

REVISIONS			
REV	DESCRIPTION	DATE	APPROVED

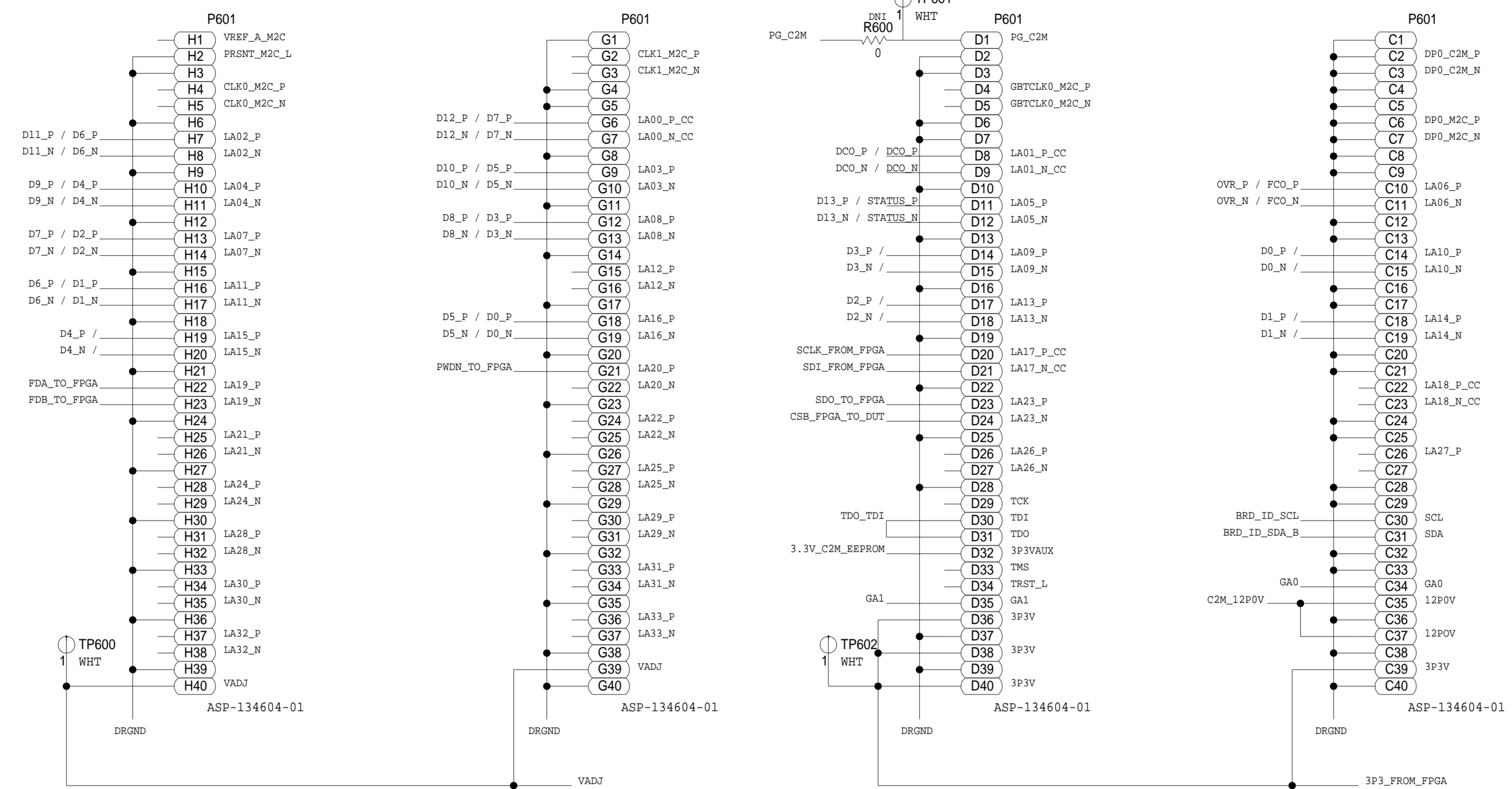

PLACE RXX - RXX AS CLOSE TO DUT AS POSSIBLE OUTSIDE OF THE SOCKET
PLACE R1 - R16 AS CLOSE TO FMC CONNECTOR AS POSSIBLE

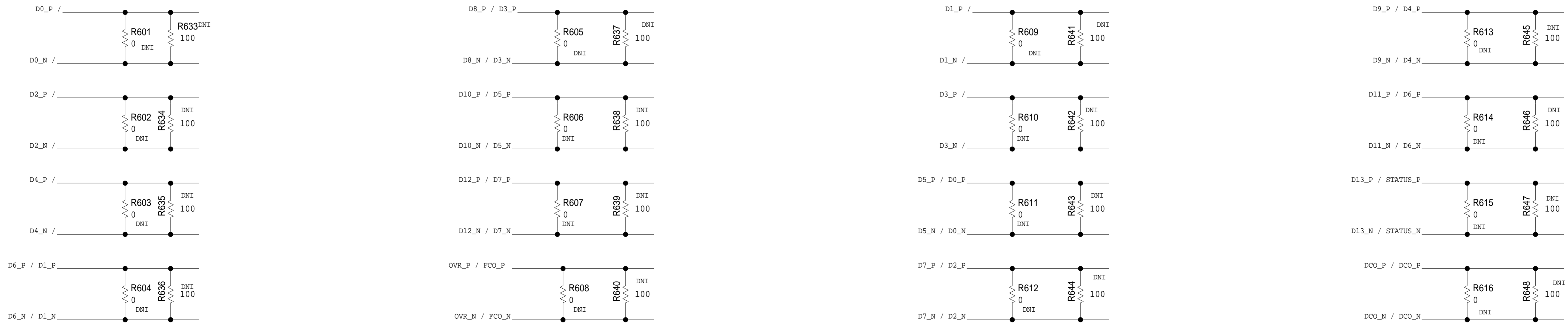

	SCHEMATIC		
	HW TYPE : Customer Evaluation Product(s) : AD9684 AD9684-500EBZ		
	DESIGN VIEW	DRAWING NO.	REV
	-	02_040108	A2
PTD ENGINEER	SIZE	SCALE	SHEET 6 OF 6
IAN BEAVERS	D	1:1	