

8 7 6 5 4 3 2 1

REVISIONS			
REV	DESCRIPTION	DATE	APPROVED

AD9213 DUAL EVB LAYOUT

CLOCKING SCHEME DETAIL

D
C
B
A

D
C
B
A

8 7 6 5 4 3 2 1

	SCHEMATIC		
	HW TYPE : Customer Evaluation Product(s): AD9213 : Dual Customer bd		
	DESIGN VIEW -	DRAWING NO. 02_049155	REV D
	PTD ENGINEER UMESH JAYAMOHAN	SIZE D	SCALE NONE
		SHEET 2 OF 16	

THIS DRAWING IS THE PROPERTY OF ANALOG DEVICES INC.
 IT IS NOT TO BE REPRODUCED OR COPIED, IN WHOLE OR
 IN PART, OR USED IN FURNISHING INFORMATION TO OTHERS,
 OR FOR ANY OTHER PURPOSE DETRIMENTAL TO THE INTERESTS
 OF ANALOG DEVICES.
 THE EQUIPMENT SHOWN HEREON MAY BE PROTECTED BY PATENTS
 OWNED OR CONTROLLED BY ANALOG DEVICES.

REVISIONS			
REV	DESCRIPTION	DATE	APPROVED

AD9213_0 CONNECTIONS

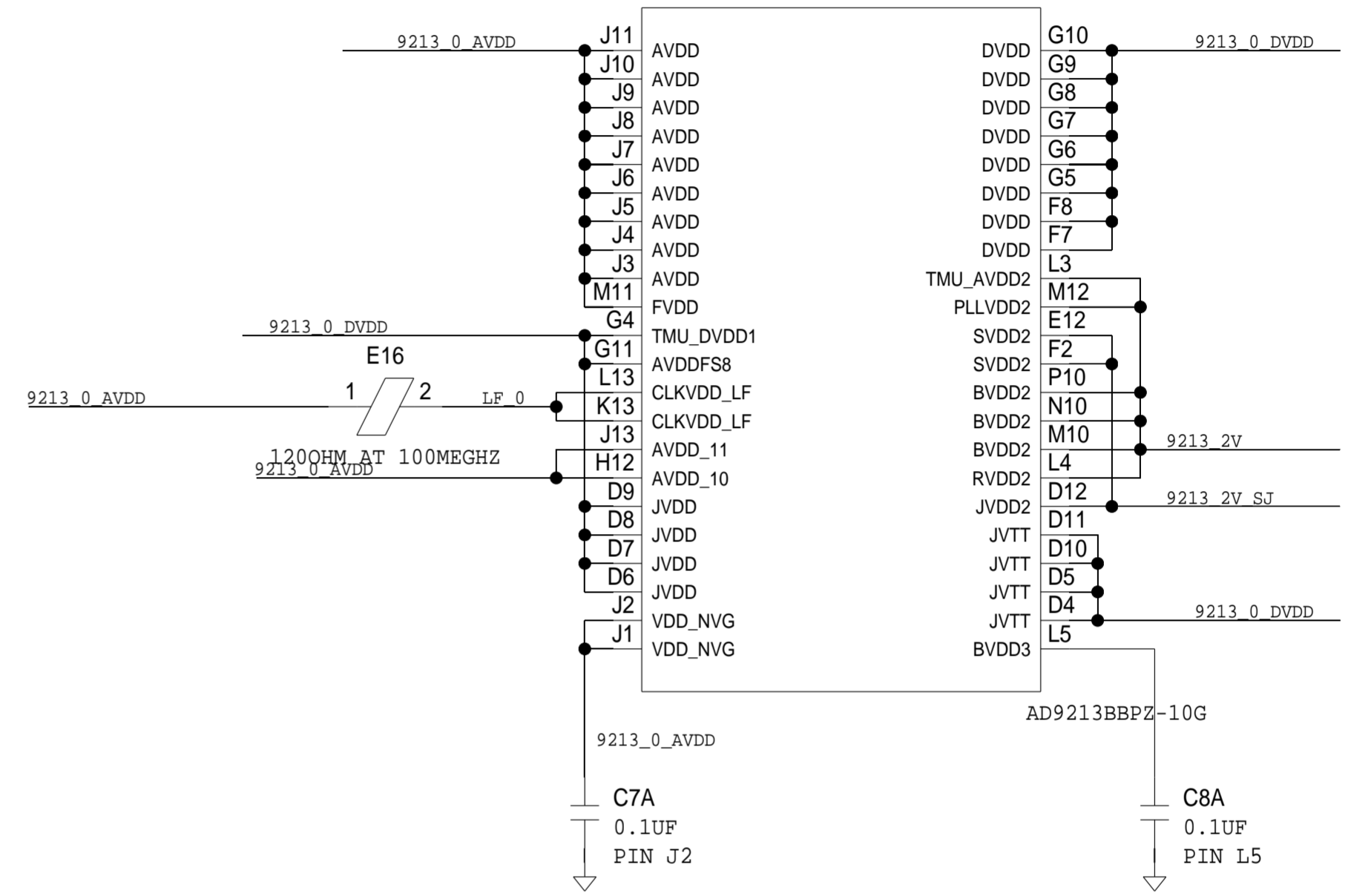
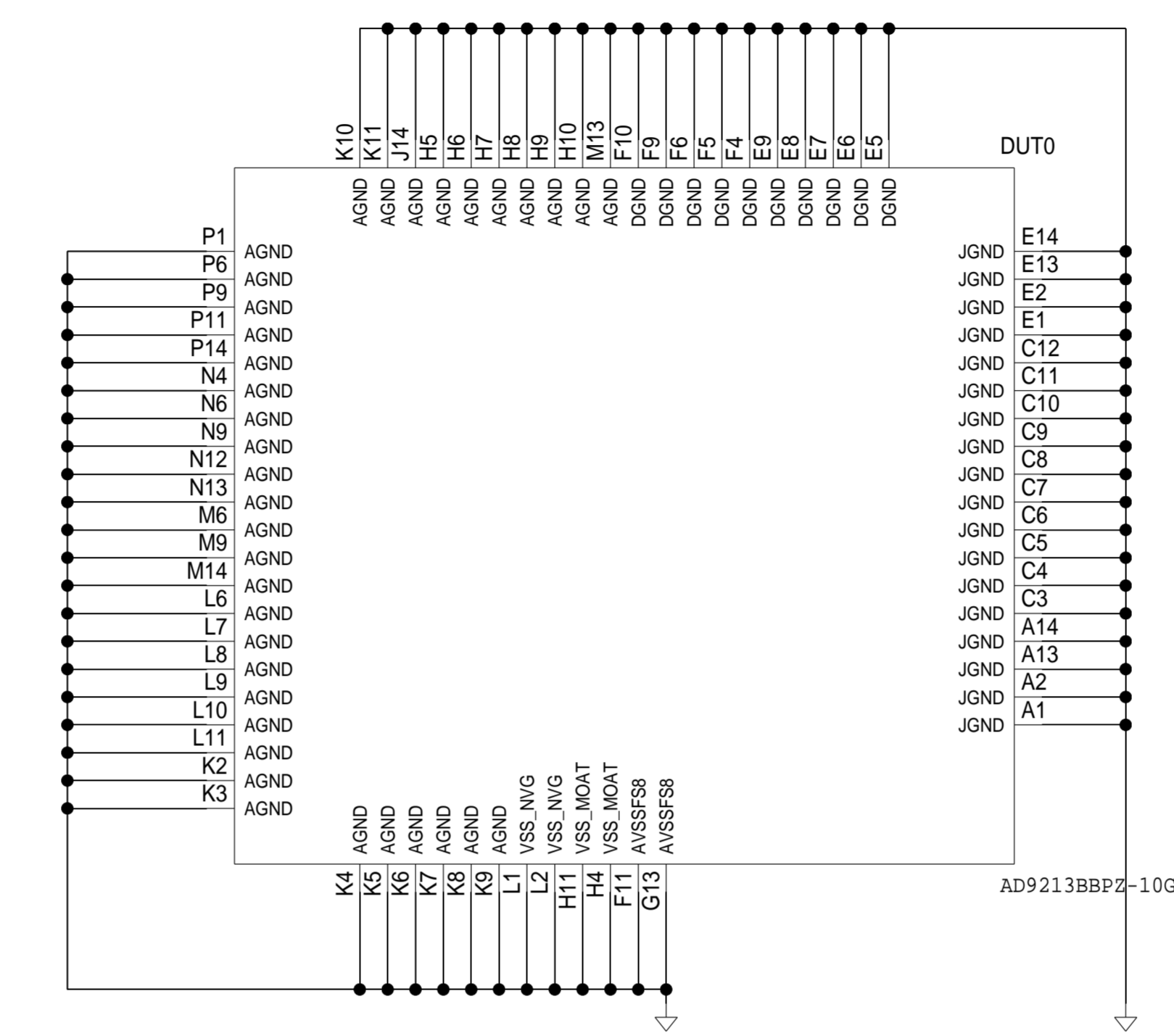
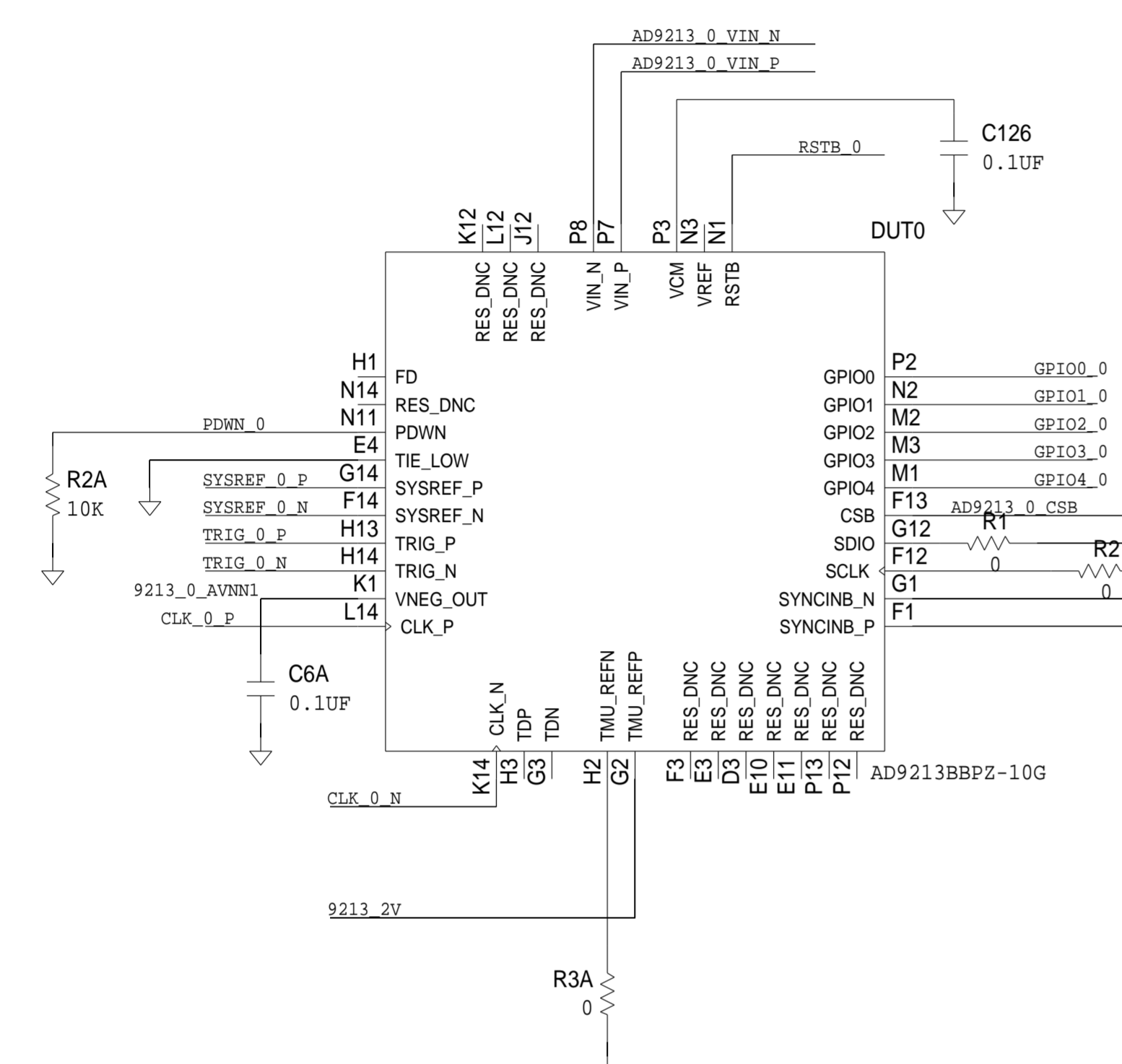

SERDOUT_N0	C11A	DOUT_N0
SERDOUT_P0	C12A 0.1UF	DOUT_P0
SERDOUT_N1	0.1UF C13A	DOUT_N1
SERDOUT_P1	C14A 0.1UF	DOUT_P1
SERDOUT_N2	0.1UF C15A	DOUT_N2
SERDOUT_P2	C16A 0.1UF	DOUT_P2
SERDOUT_N3	0.1UF C17A	DOUT_N3
SERDOUT_P3	C18A 0.1UF	DOUT_P3
SERDOUT_N4	0.1UF C19A	DOUT_N4
SERDOUT_P4	C20A 0.1UF	DOUT_P4
SERDOUT_N5	0.1UF C21A	DOUT_N5
SERDOUT_P5	C22A 0.1UF	DOUT_P5
SERDOUT_N6	0.1UF C23A	DOUT_N6
SERDOUT_P6	C24A 0.1UF	DOUT_P6
SERDOUT_N7	0.1UF C25A	DOUT_N7
SERDOUT_P7	C26A 0.1UF	DOUT_P7
SERDOUT_N8	C27A	DOUT_N8
SERDOUT_P8	C28A 0.1UF	DOUT_P8
SERDOUT_N9	0.1UF C29A	DOUT_N9
SERDOUT_P9	C30A 0.1UF	DOUT_P9
SERDOUT_N10	0.1UF C31A	DOUT_N10
SERDOUT_P10	C32A 0.1UF	DOUT_P10
SERDOUT_N11	0.1UF C33A	DOUT_N11
SERDOUT_P11	C34A 0.1UF	DOUT_P11
SERDOUT_N12	0.1UF C35A	DOUT_N12
SERDOUT_P12	C36A 0.1UF	DOUT_P12
SERDOUT_N13	0.1UF C37A	DOUT_N13
SERDOUT_P13	C38A 0.1UF	DOUT_P13
SERDOUT_N14	0.1UF C39A	DOUT_N14
SERDOUT_P14	C40A 0.1UF	DOUT_P14
SERDOUT_N15	0.1UF C41A	DOUT_N15
SERDOUT_P15	C42A 0.1UF	DOUT_P15

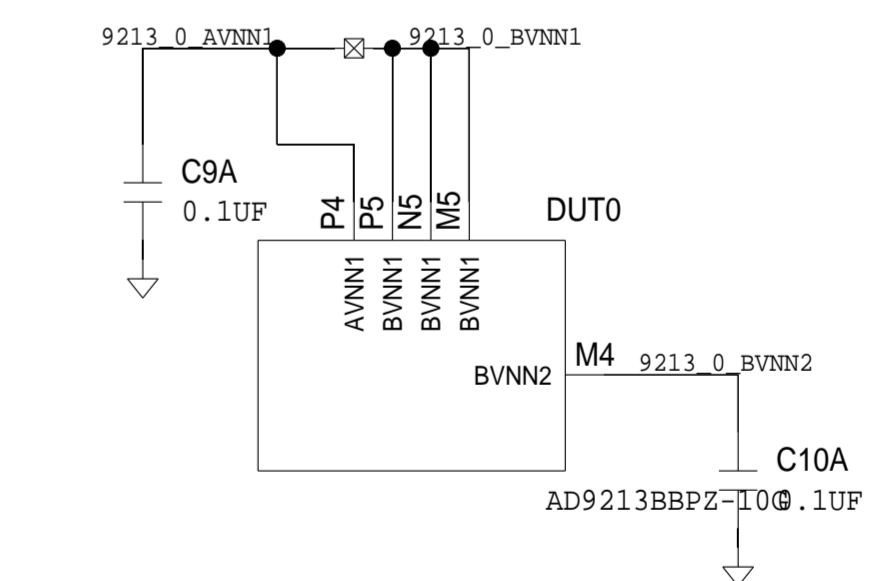
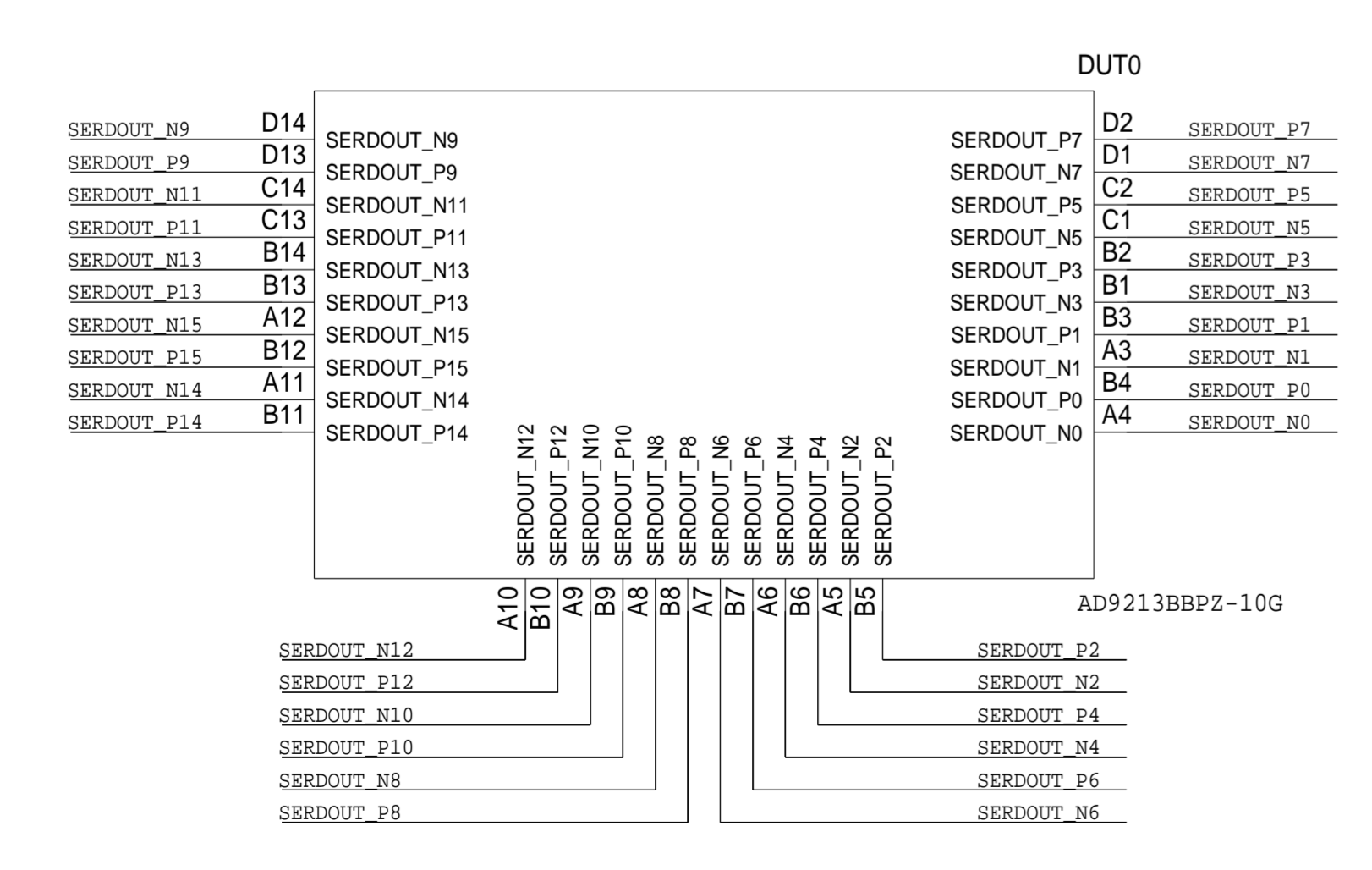

	SCHEMATIC		
	HW TYPE : Customer Evaluation Product(s): AD9213 : Dual Customer bd		
DESIGN VIEW	DRAWING NO.		REV
-	02_049155		D
PTD ENGINEER	SIZE	SCALE	SHEET 3 OF 16
UMESH JAYAMOHAN	D	NONE	

AD9213_1 CONNECTIONS

REVISIONS			
REV	DESCRIPTION	DATE	APPROVED

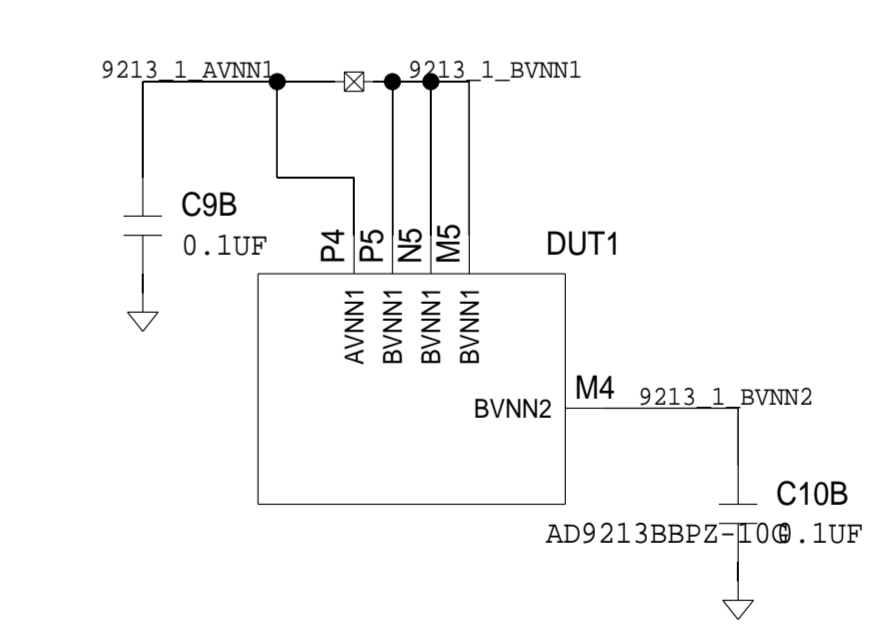
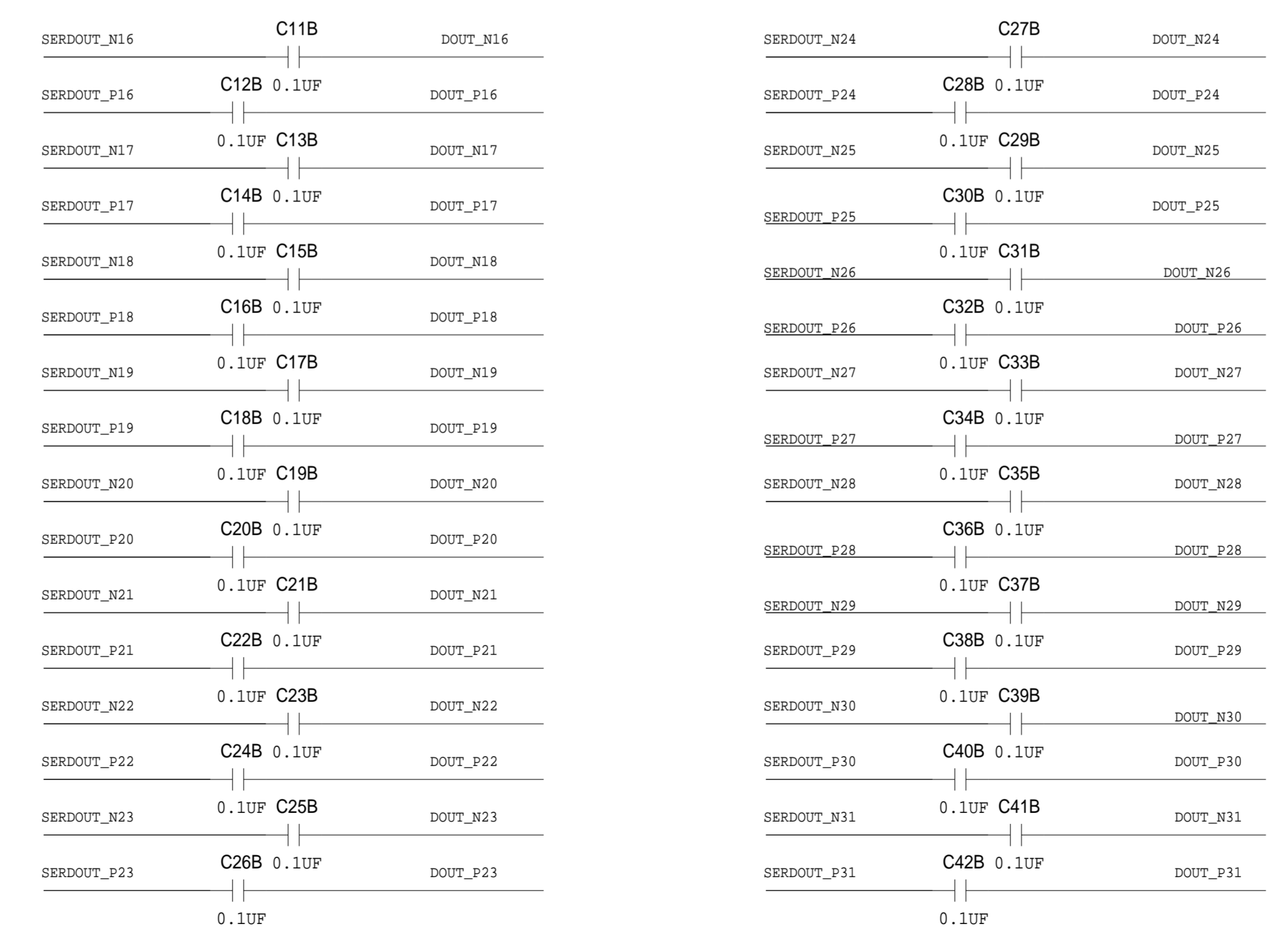
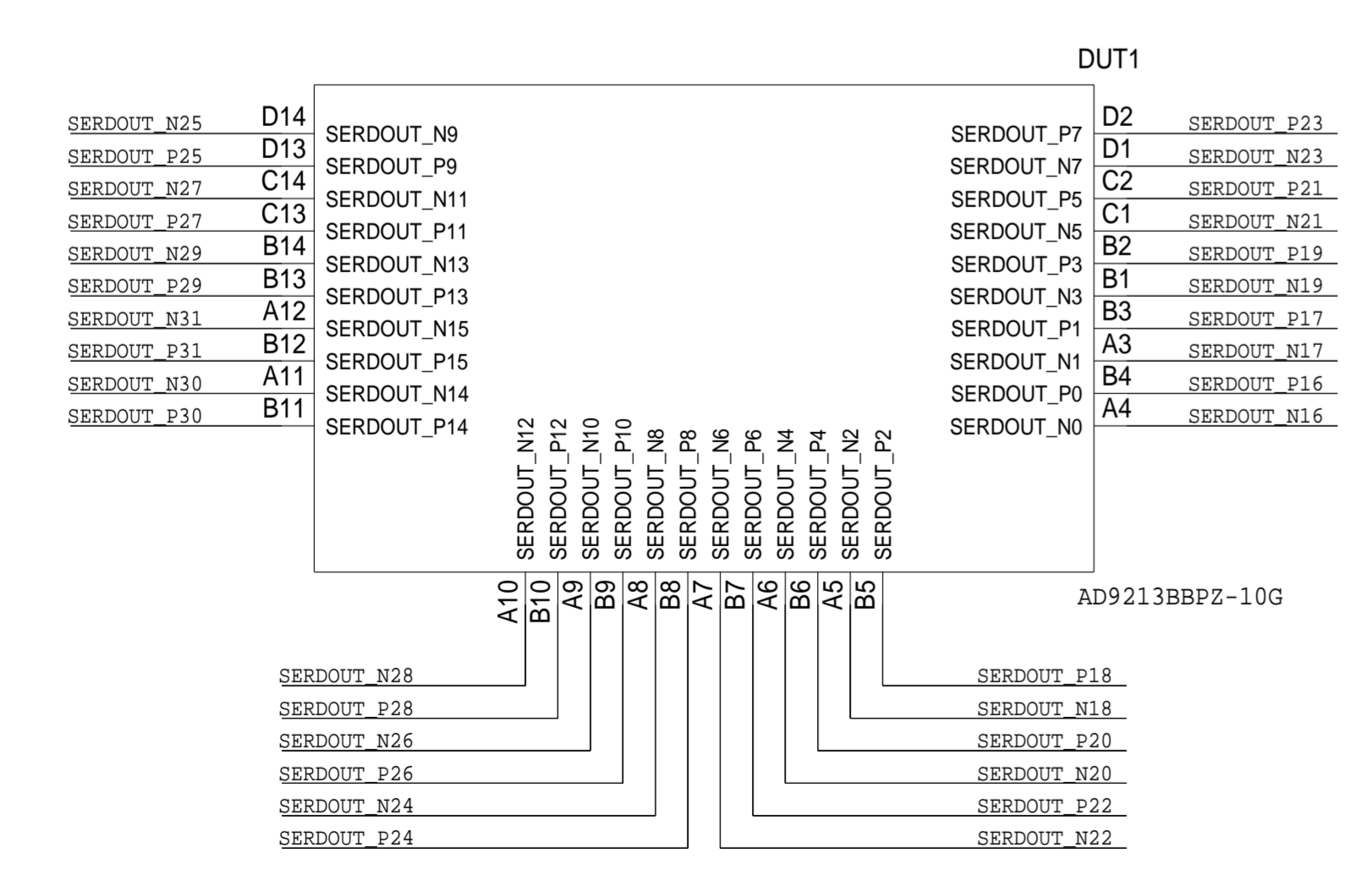
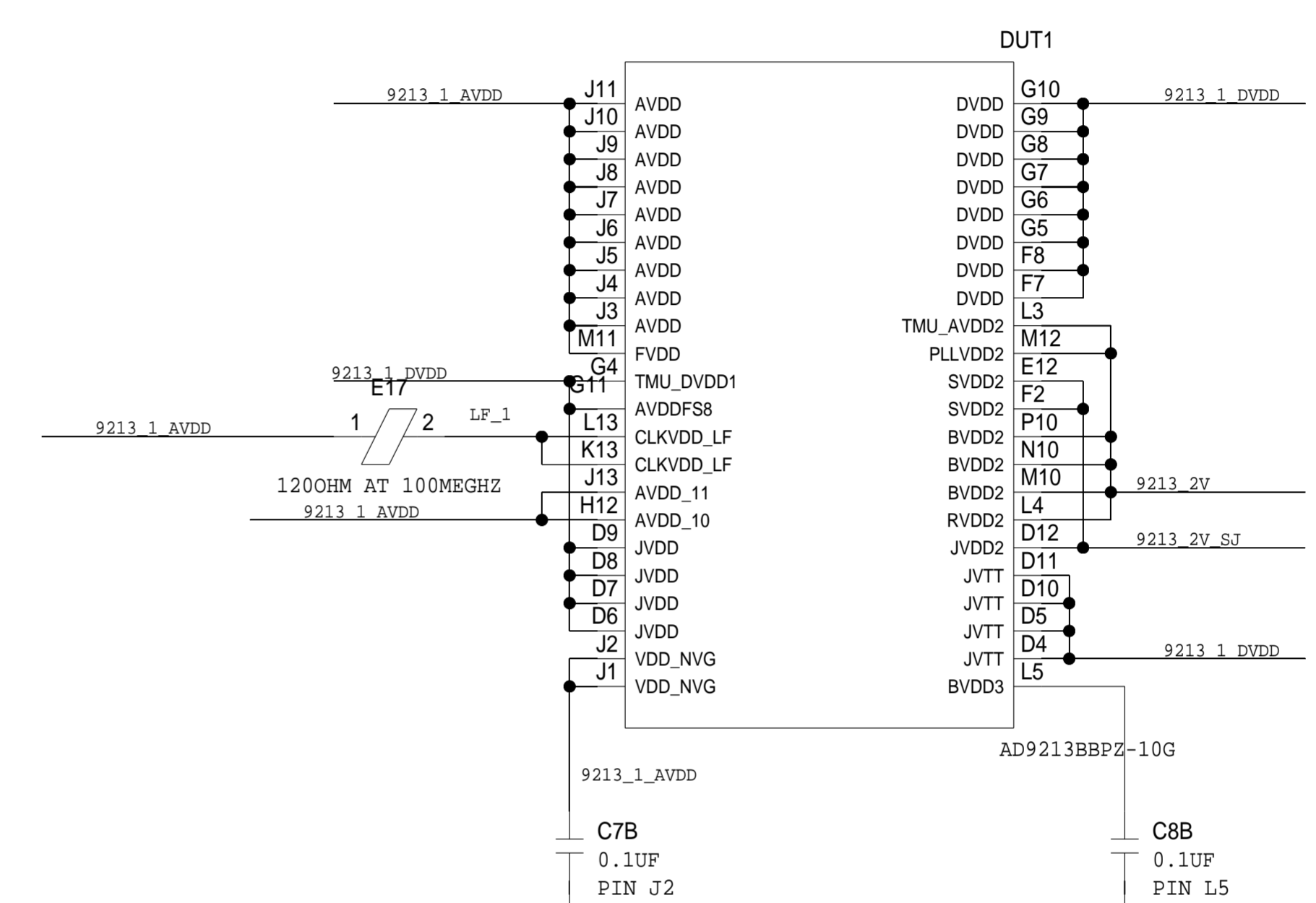
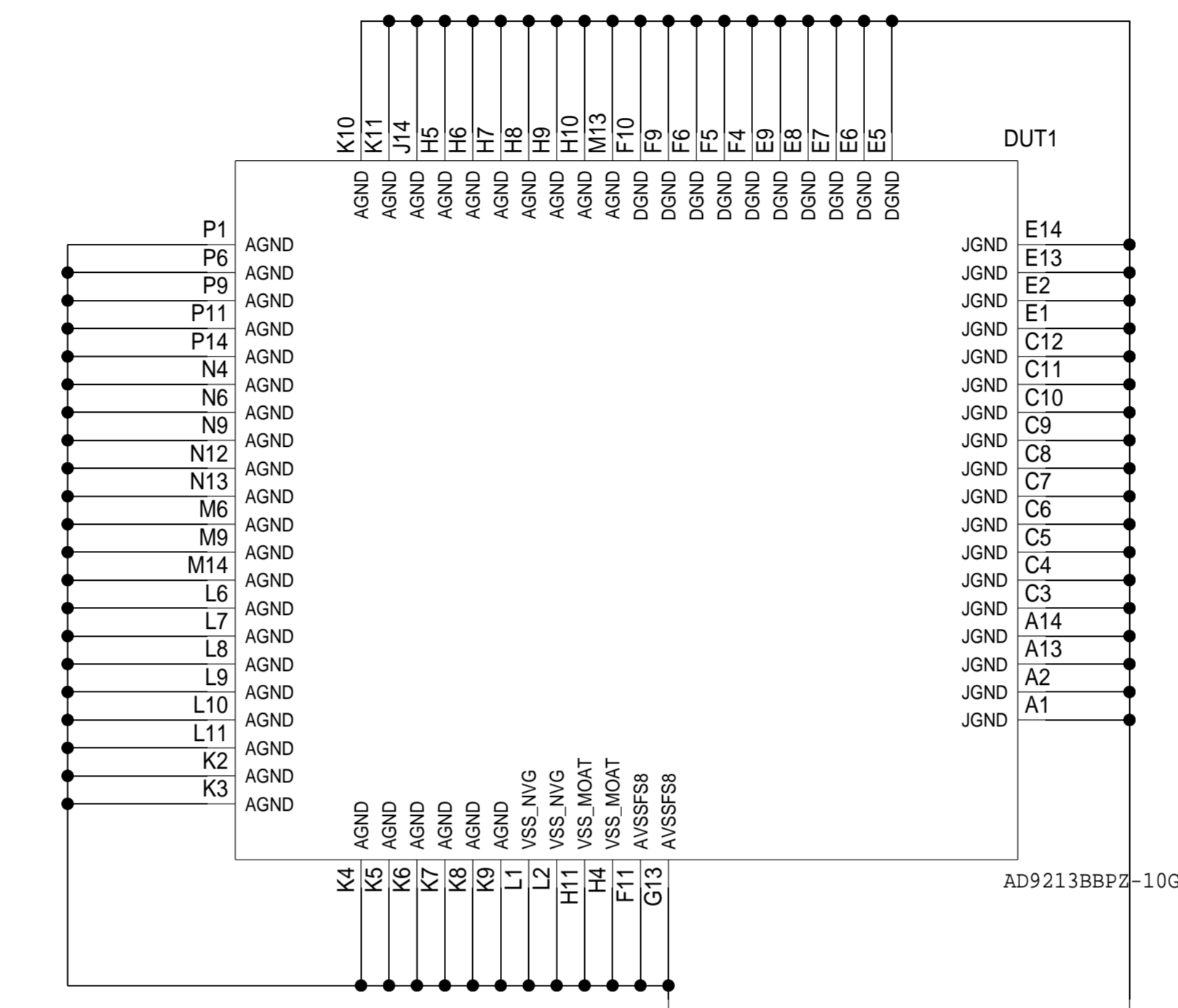
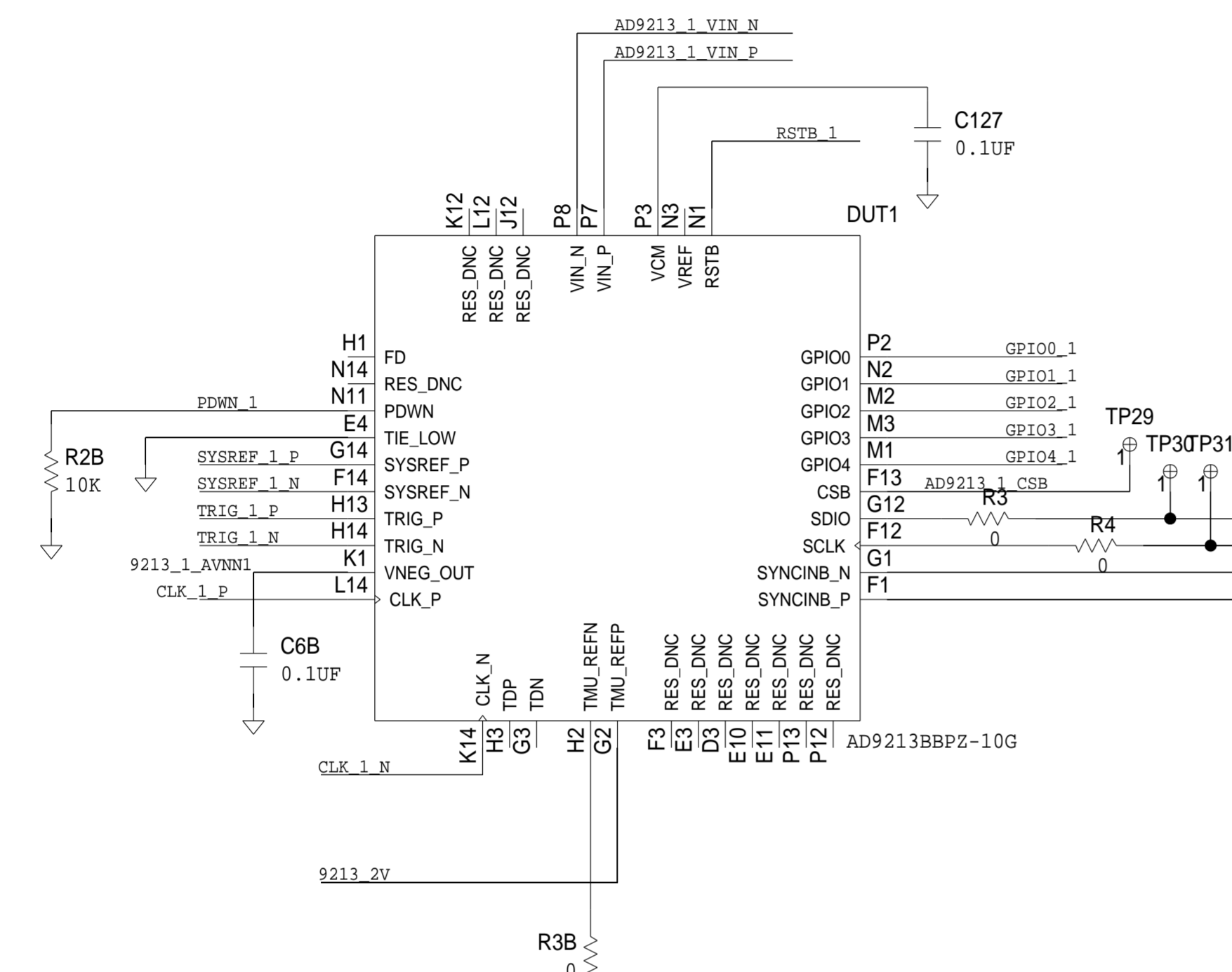

ANALOG DEVICES		SCHEMATIC			
HW TYPE : Customer Evaluation Product(s) : AD9213 : Dual Customer bd		DESIGN VIEW		DRAWING NO.	
-		-		02_049155	
PTD ENGINEER		SIZE		SCALE	
UMESH JAYAMOCHAN		D		NONE	
		SHEET 4		OF 16	
		REV		D	

THIS DRAWING IS THE PROPERTY OF ANALOG DEVICES INC. IT IS NOT TO BE REPRODUCED OR COPIED, IN WHOLE OR IN PART, OR USED IN FURNISHING INFORMATION TO OTHERS, OR FOR ANY OTHER PURPOSE DETRIMENTAL TO THE INTERESTS OF ANALOG DEVICES. THE EQUIPMENT SHOWN HEREON MAY BE PROTECTED BY PATENTS OWNED OR CONTROLLED BY ANALOG DEVICES.

REVISIONS			
REV	DESCRIPTION	DATE	APPROVED

DECOUPLING CAPACITORS DIRECTLY BELOW BGA FOOTPRINT FOR AD9213_0

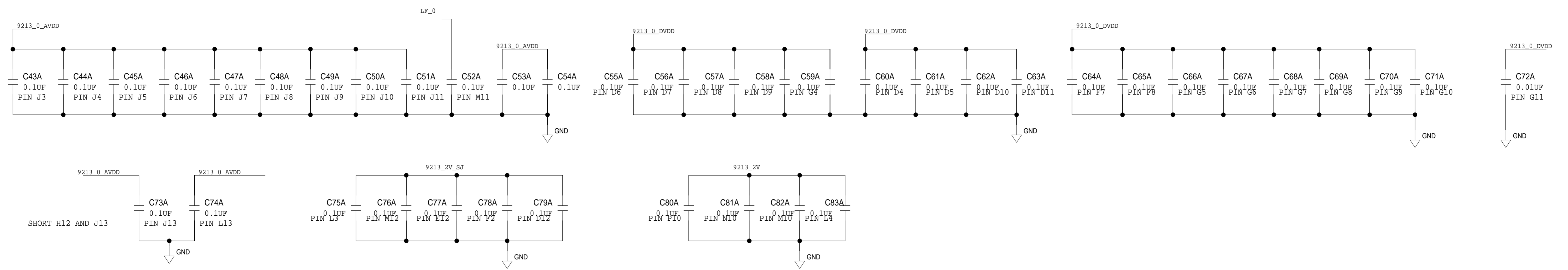

DECOUPLING CAPACITORS DIRECTLY BELOW BGA FOOTPRINT FOR AD9213_1

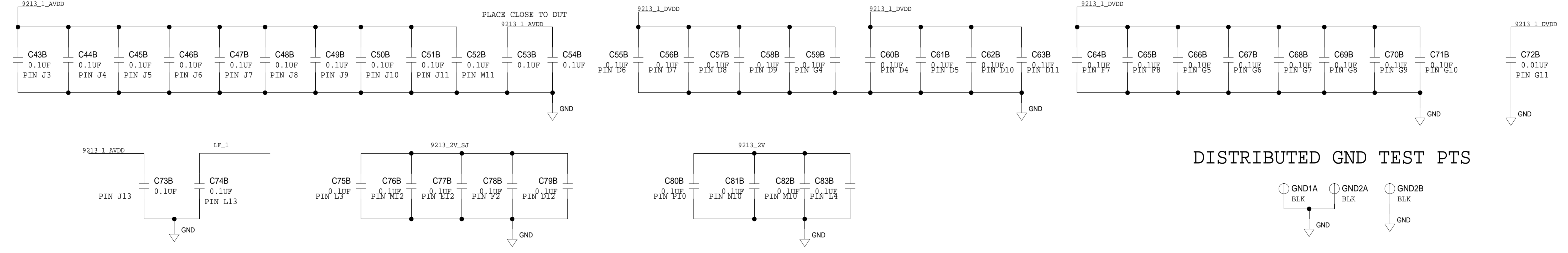

DISTRIBUTED GND TEST PTS

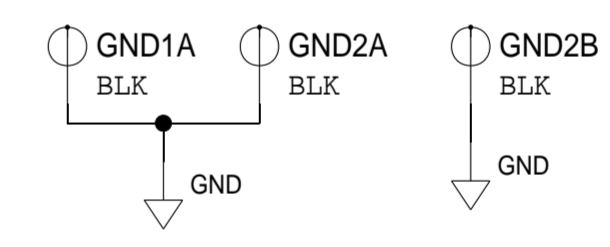

DISTRIBUTED DECOUPLING CAPACITORS

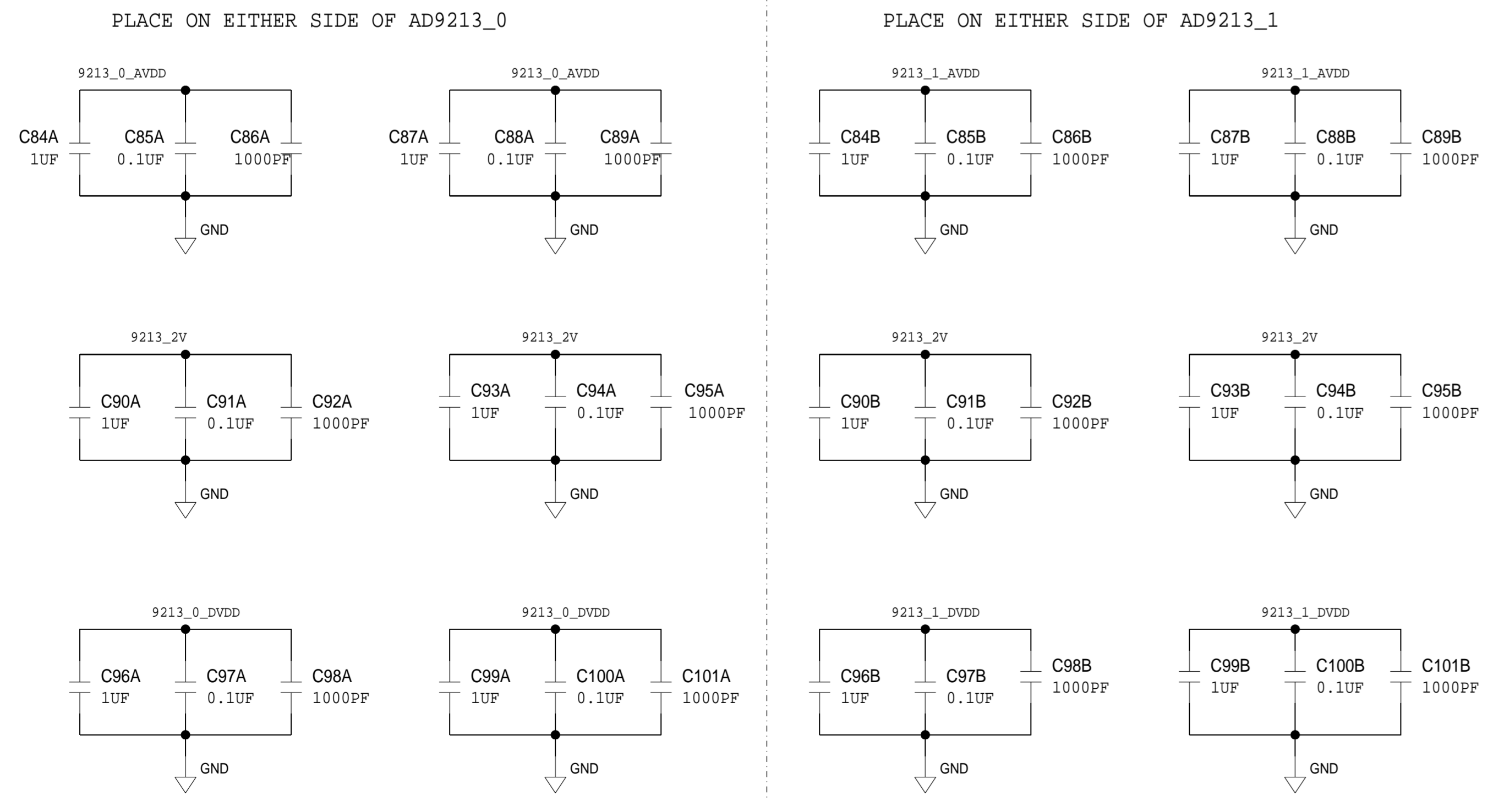

	SCHEMATIC			
	HW TYPE : Customer Evaluation			
	Product(s) : AD9213			
	: Dual Customer bd			
DESIGN VIEW	DRAWING NO.		REV	
-	02_049155		D	
PTD ENGINEER	SIZE	SCALE	SHEET 5 OF 16	
UMESH JAYAMOHAN	D	NONE		

REVISIONS			
REV	DESCRIPTION	DATE	APPROVED

ANALOG FRONT END

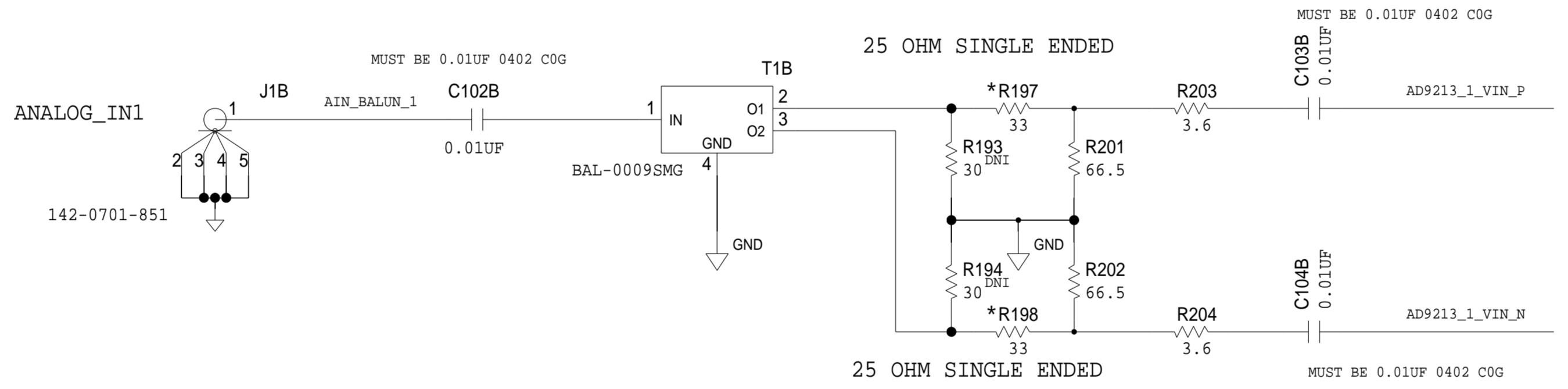
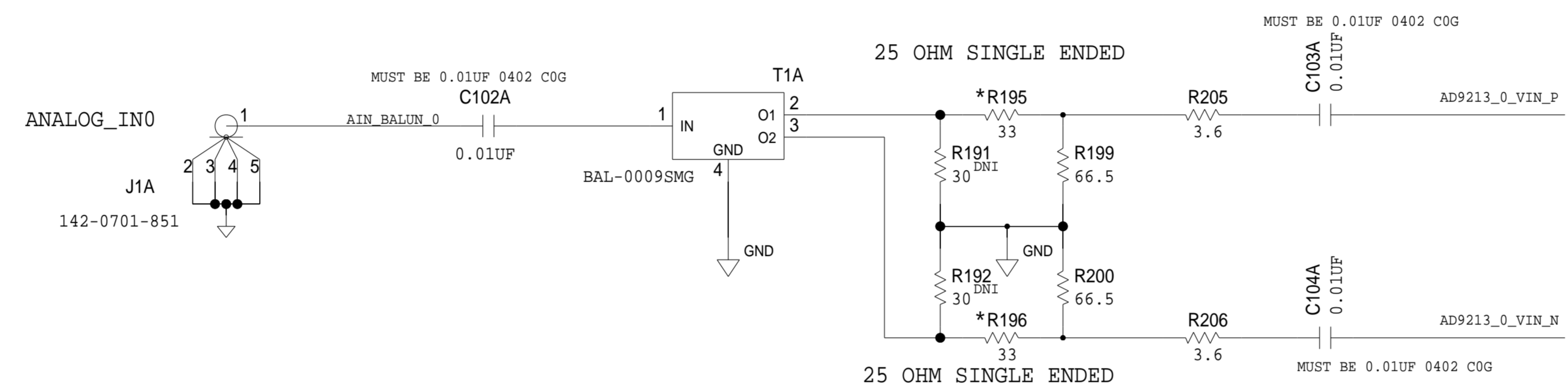

	SCHEMATIC		
	HW TYPE : Customer Evaluation Product(s): AD9213 : Dual Customer bd		
	DESIGN VIEW -	DRAWING NO. 02_049155	REV D
PTD ENGINEER UMESH JAYAMOHAN	SIZE D	SCALE NONE	SHEET 6 OF 16

LTC6952 CLOCK AND CONNECTIONS

REVISIONS			
REV	DESCRIPTION	DATE	APPROVED

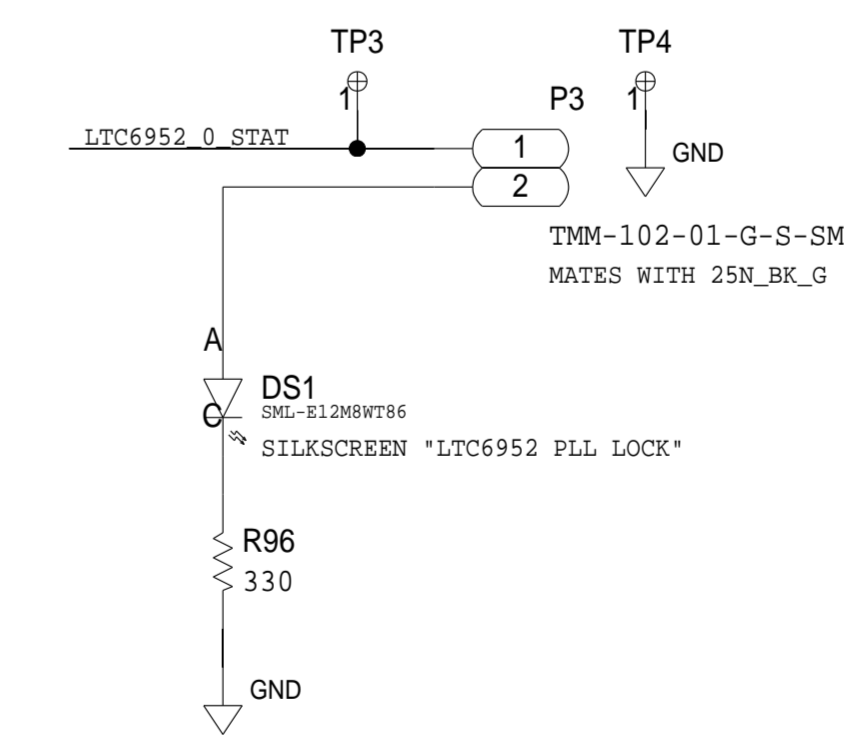
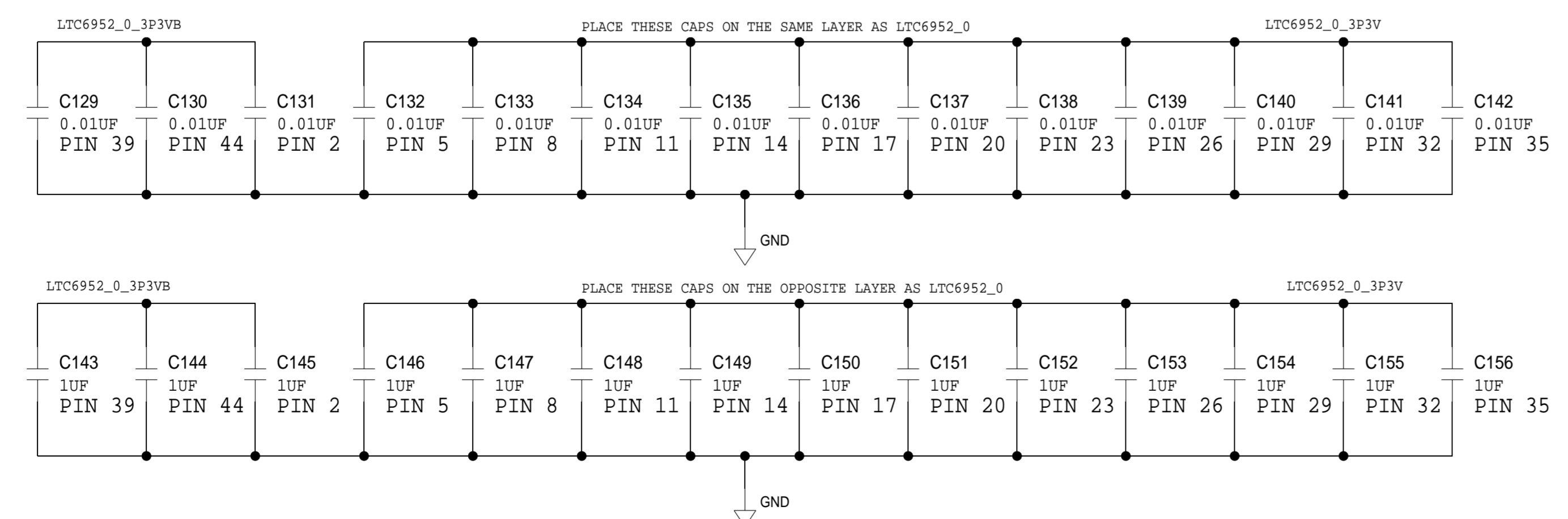
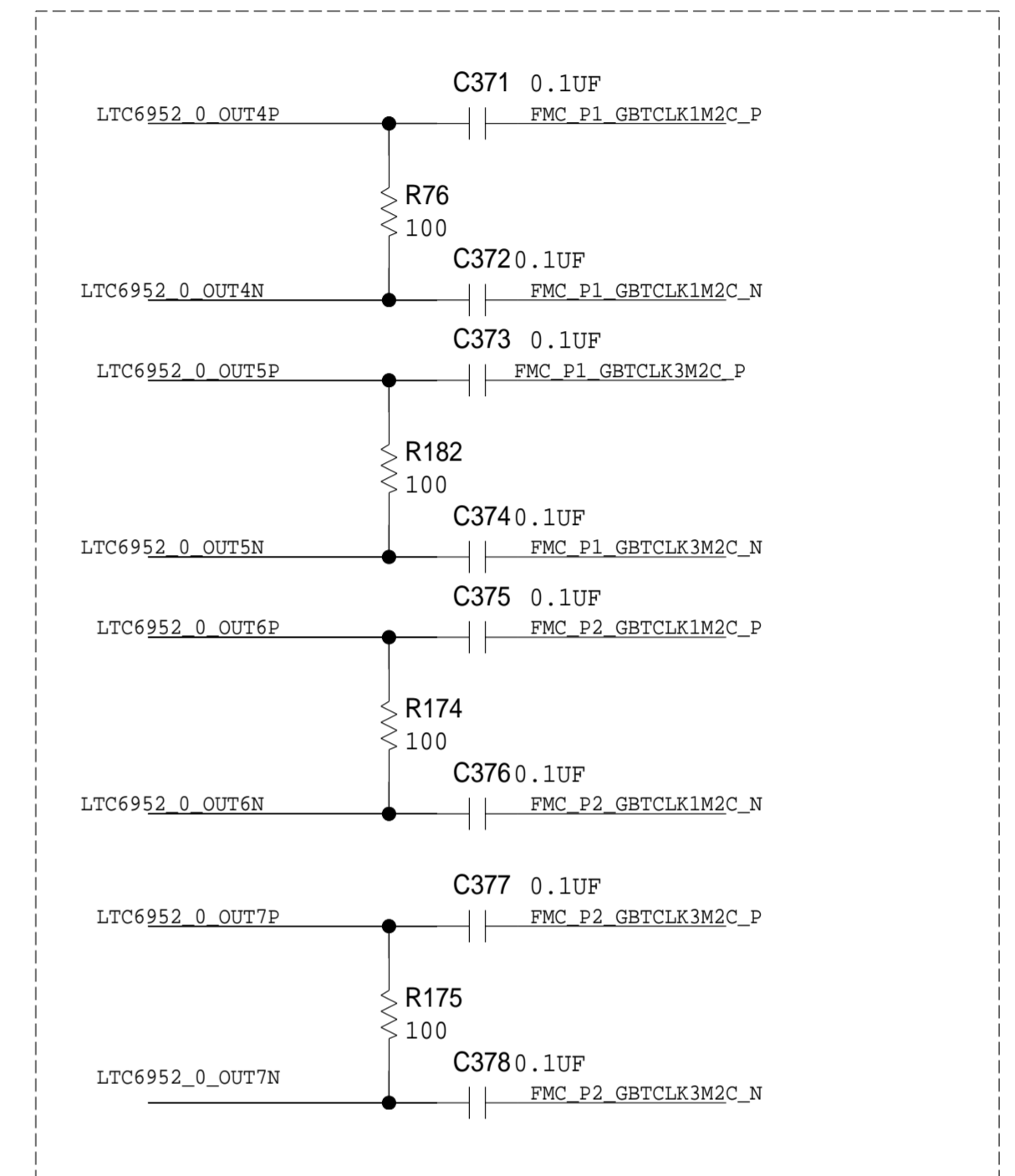
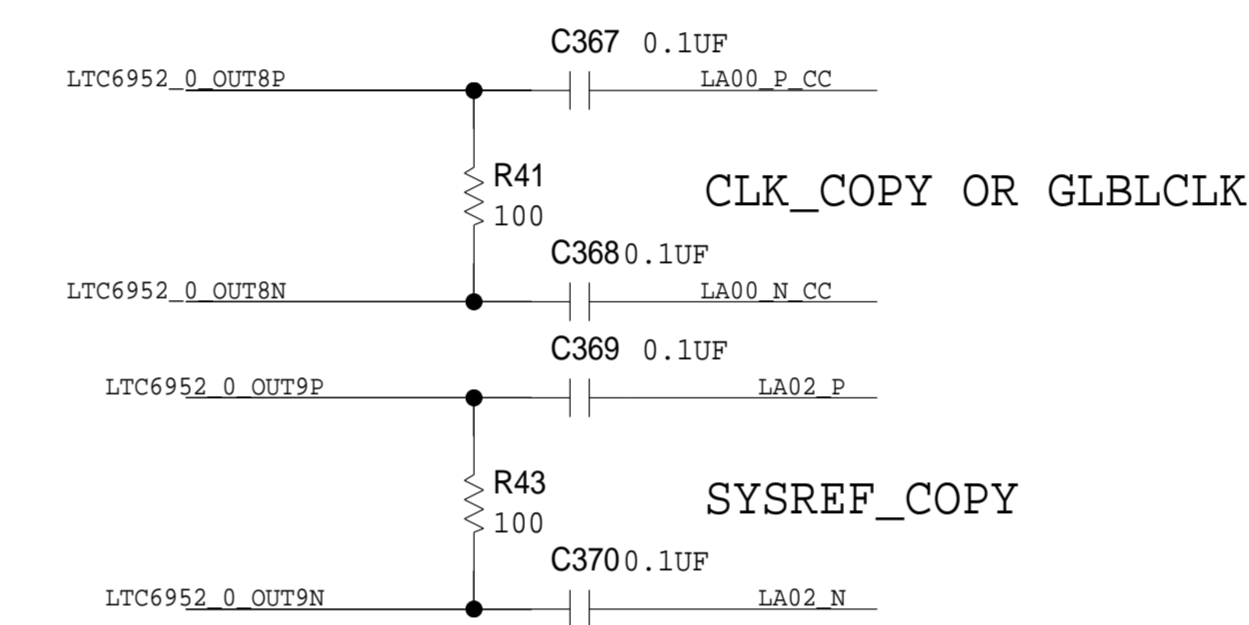
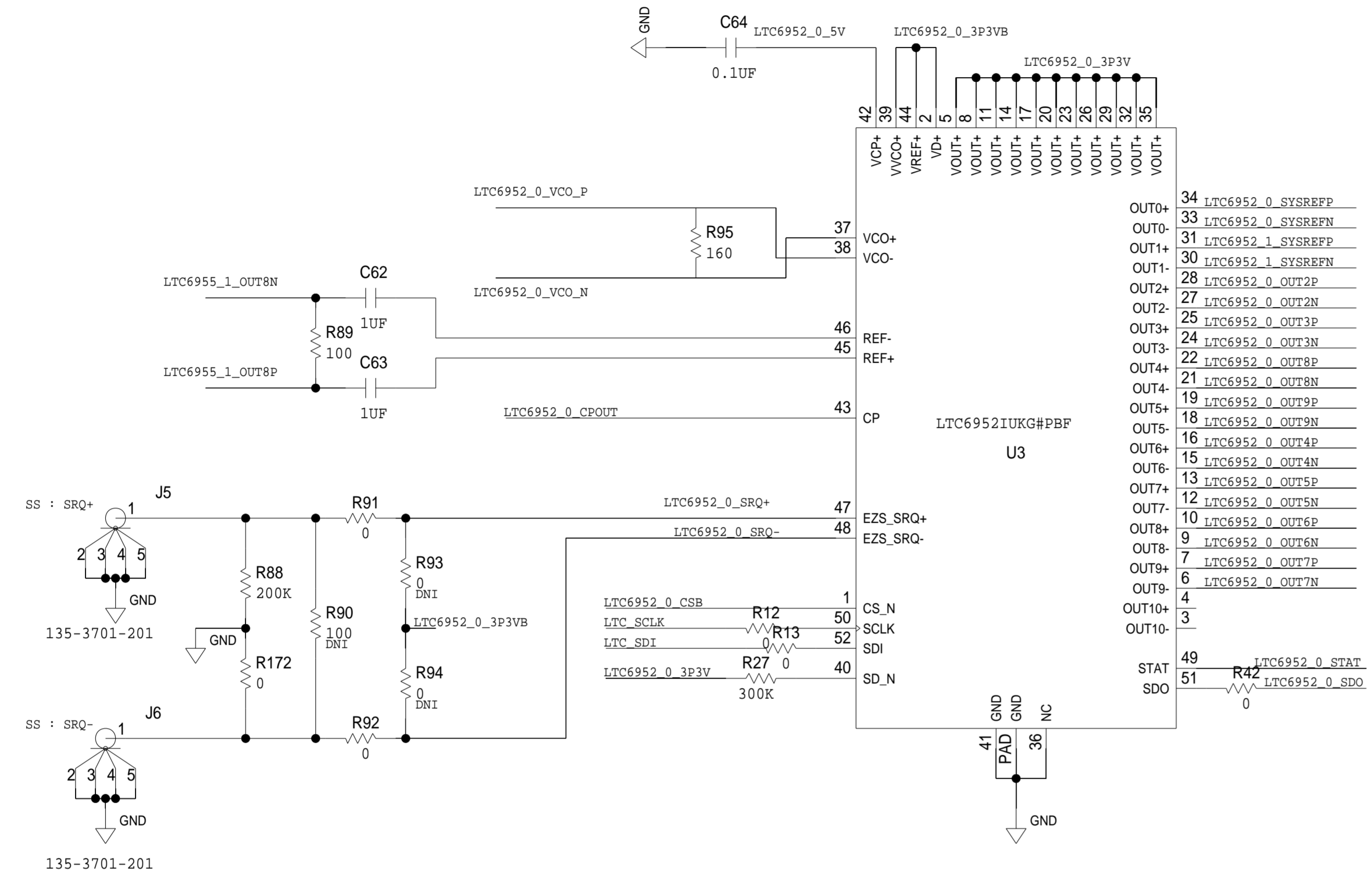

SCHEMATIC			
		HW TYPE : Customer Evaluation Product(s): AD9213 : Dual Customer bd	
DESIGN VIEW	-	DRAWING NO.	REV
PTD ENGINEER	UMESH JAYAMOHAN	02_049155	D
SIZE	SCALE	SHEET 7 OF 16	
D	NONE		

THIS DRAWING IS THE PROPERTY OF ANALOG DEVICES INC. IT IS NOT TO BE REPRODUCED OR COPIED, IN WHOLE OR IN PART, OR USED IN FURNISHING INFORMATION TO OTHERS, OR FOR ANY OTHER PURPOSE DETRIMENTAL TO THE INTERESTS OF ANALOG DEVICES. THE EQUIPMENT SHOWN HEREIN MAY BE PROTECTED BY PATENTS OWNED OR CONTROLLED BY ANALOG DEVICES.

REFERENCE CLOCK GENERATION AND DISTRIBUTION

REVISIONS			
REV	DESCRIPTION	DATE	APPROVED

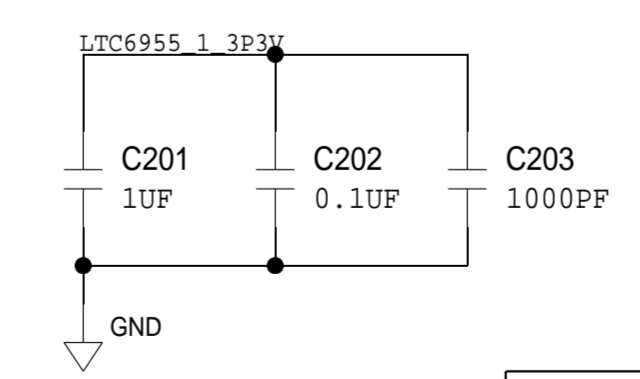
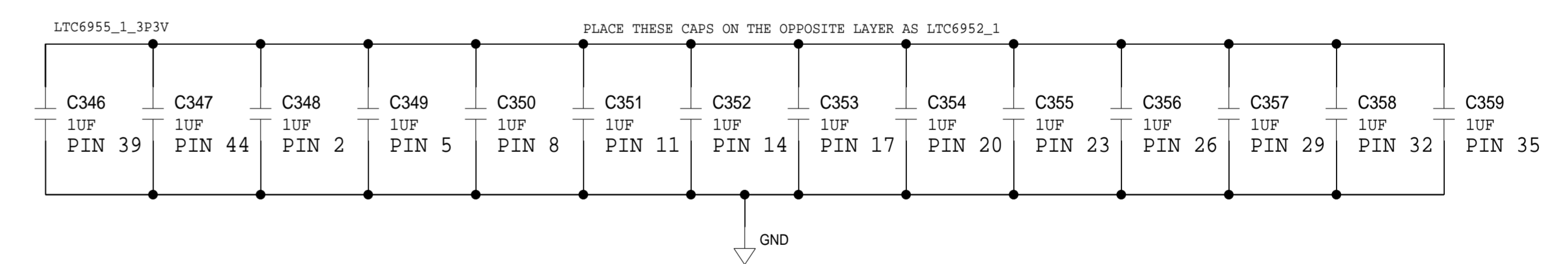
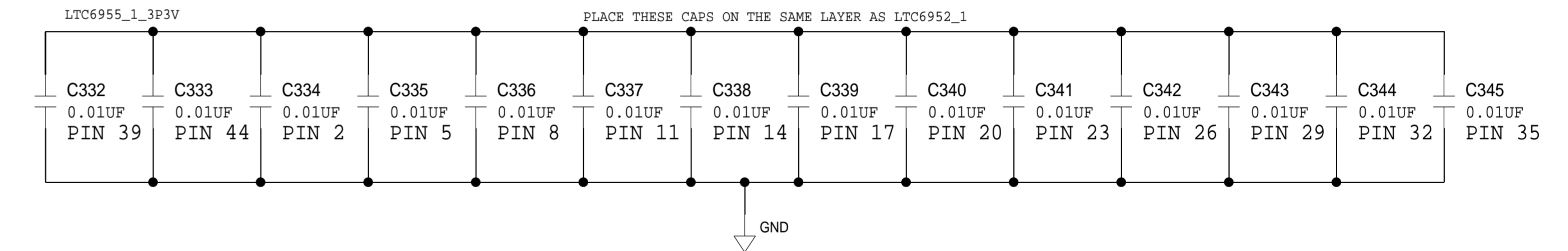
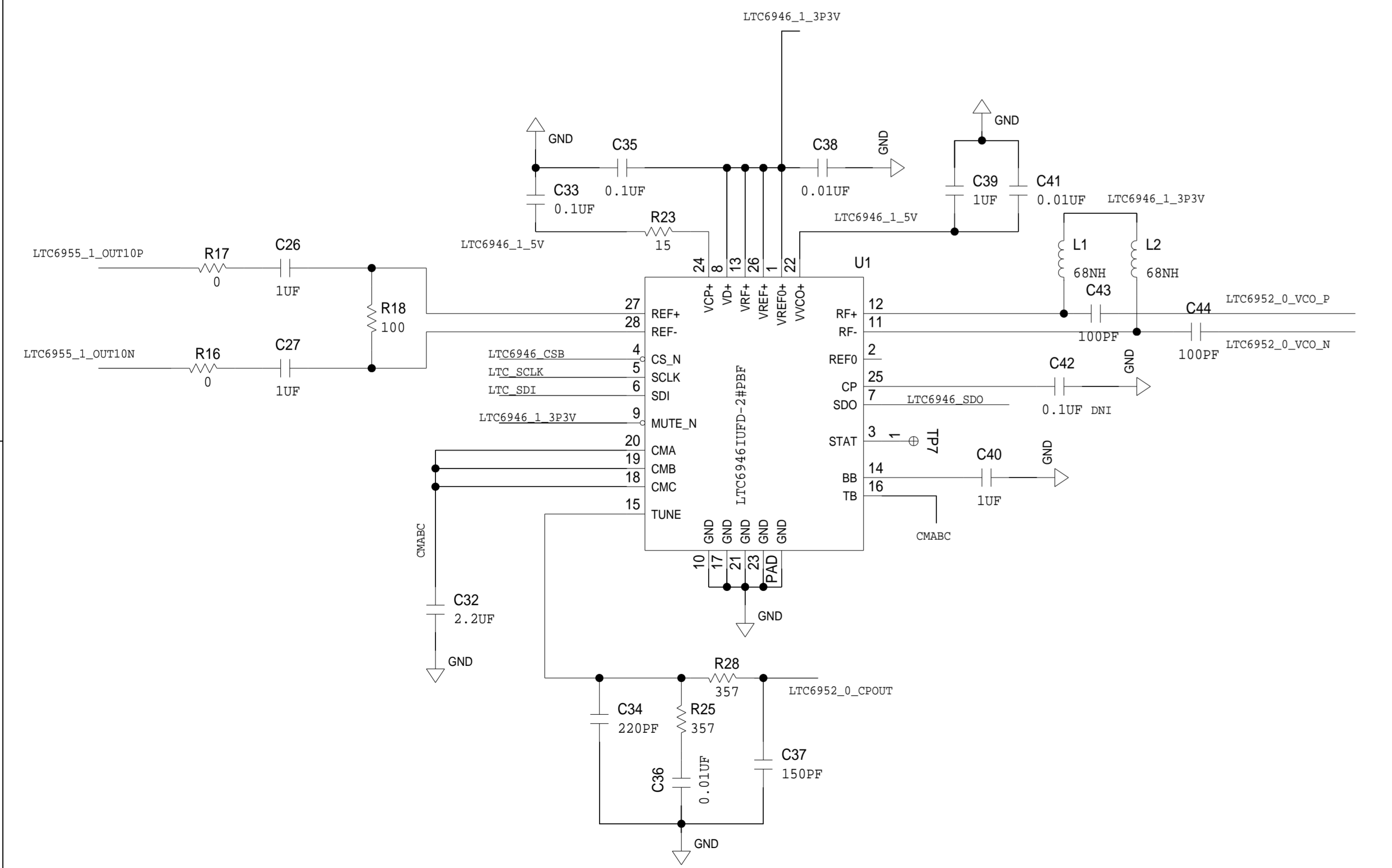
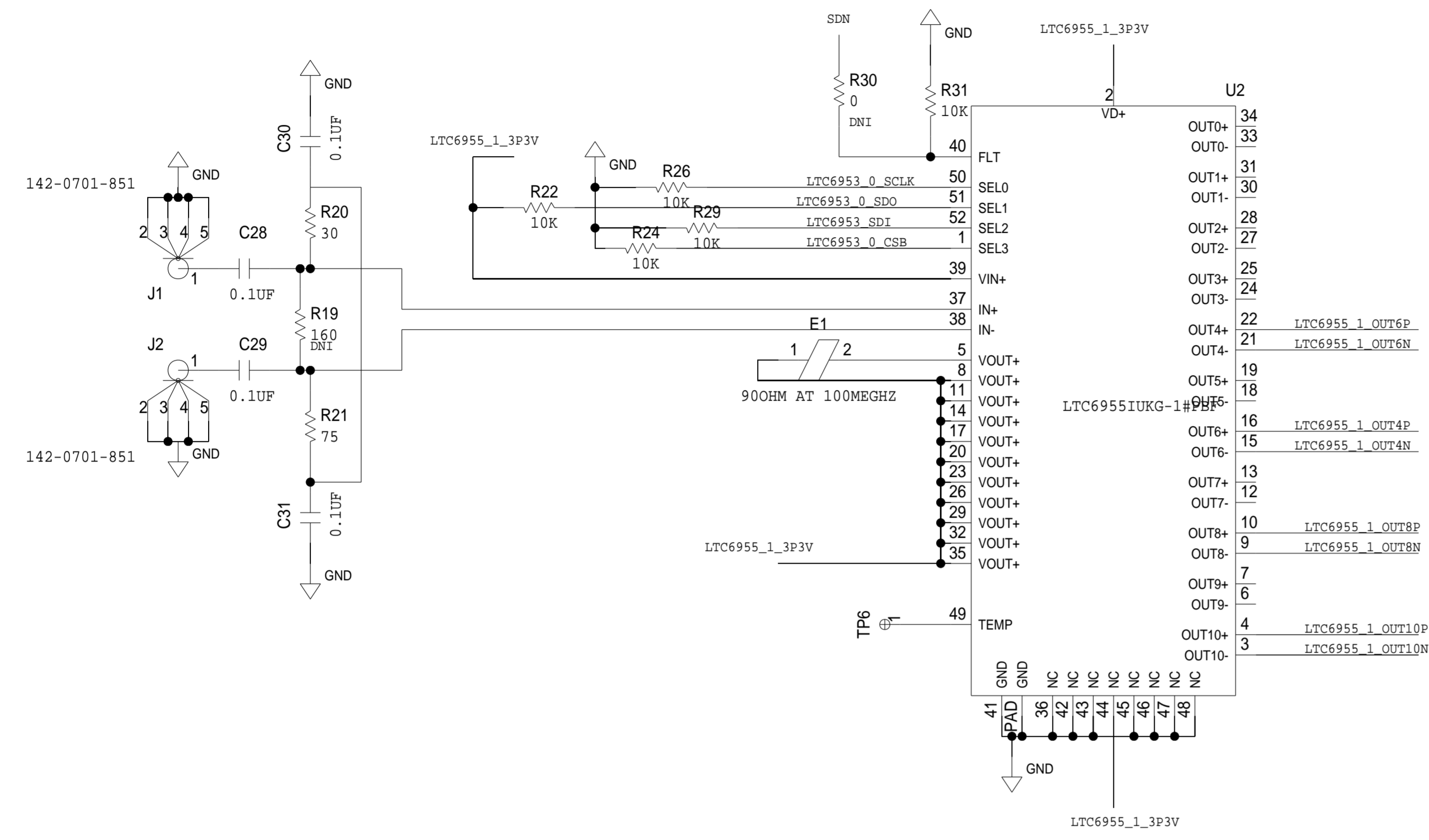

ANALOG DEVICES			
HW TYPE : Customer Evaluation Product(s) : AD9213 : Dual Customer bd		SCHEMATIC	
DESIGN VIEW	-	DRAWING NO.	02_049155
PTD ENGINEER	UMESH JAYAMOCHAN	SIZE	D
		SCALE	NONE
		SHEET	8 OF 16
		REV	D

DC-DC CONVERTER FOR CLOCK SUPPLIES

REVISIONS			
REV	DESCRIPTION	DATE	APPROVED

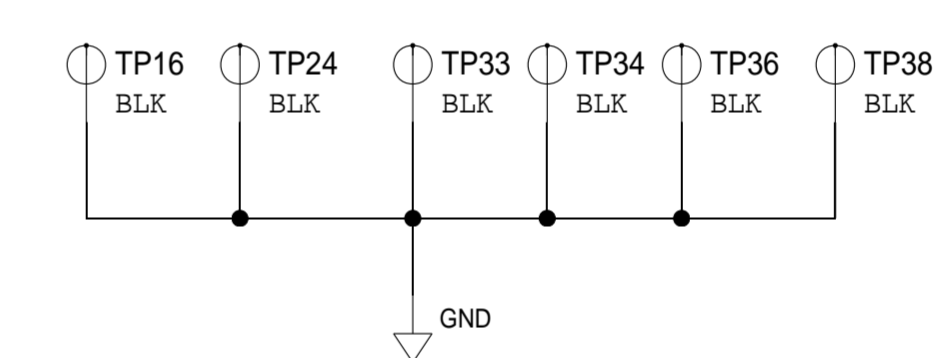
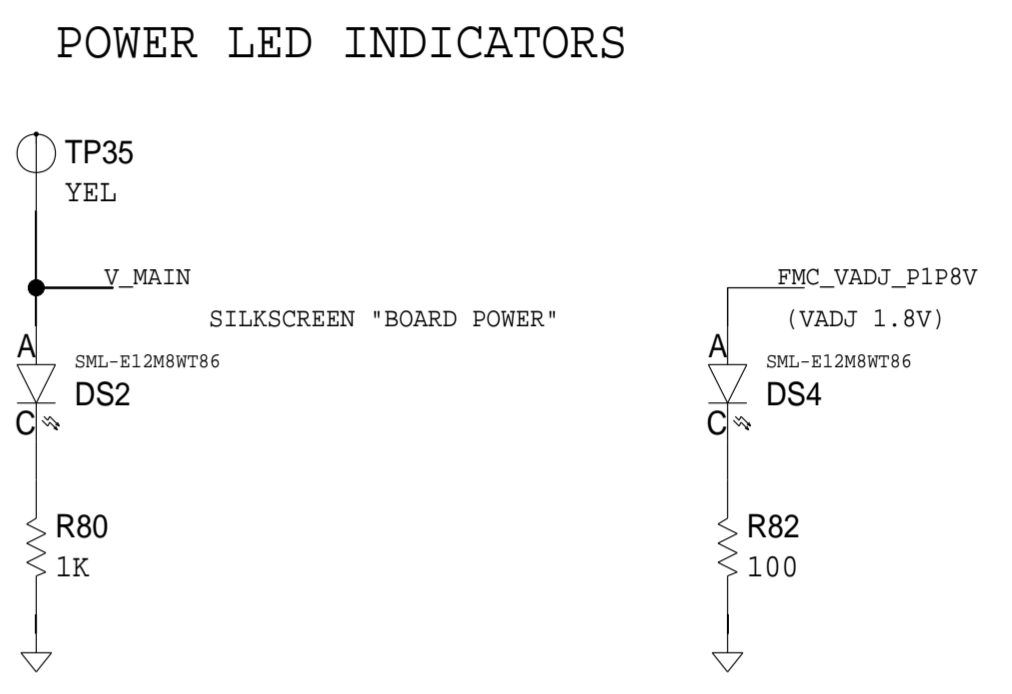
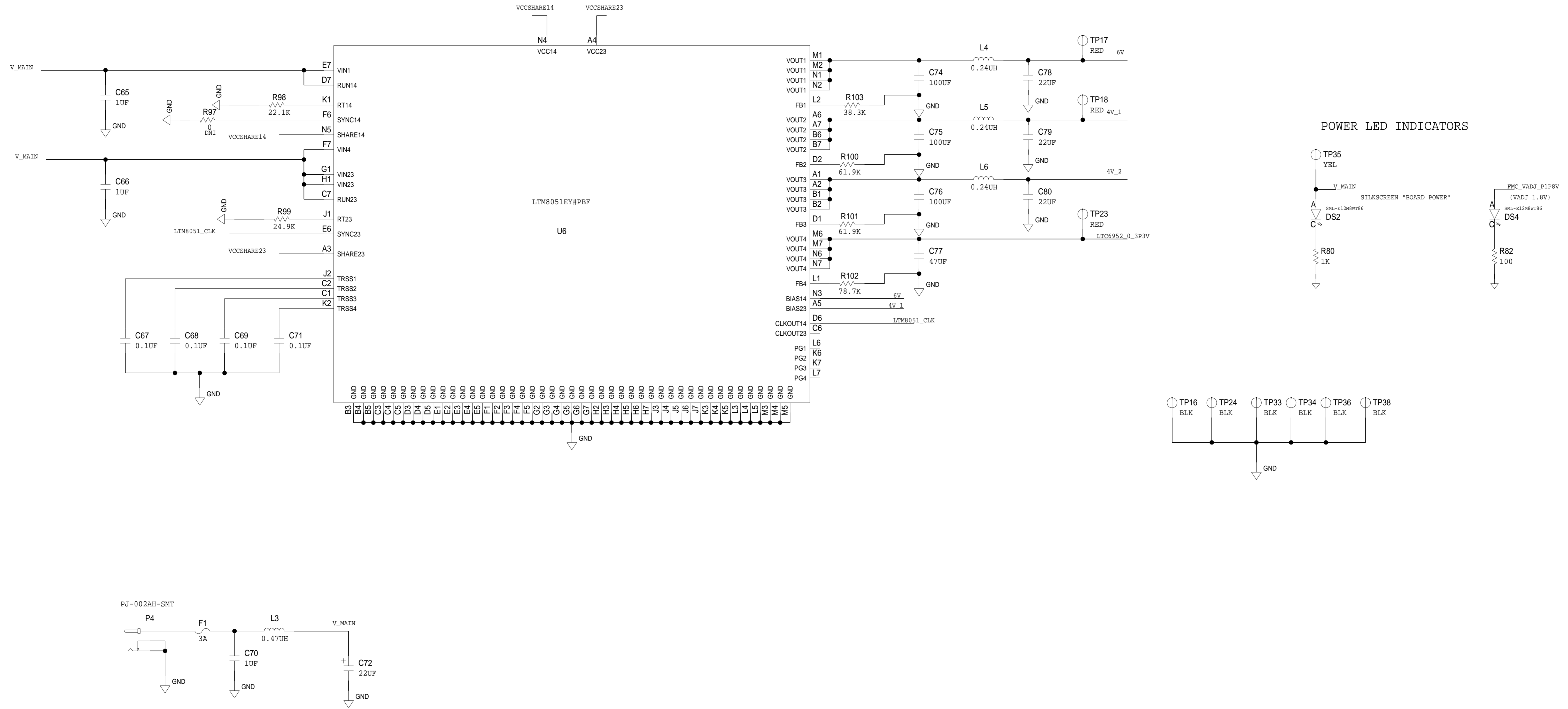

	SCHEMATIC			
	HW TYPE : Customer Evaluation Product(s) : AD9213 : Dual Customer bd			
	DESIGN VIEW	DRAWING NO.	REV	
	-	02_049155	D	
PTD ENGINEER	SIZE	SCALE	SHEET 10 OF 16	
UMESH JAYAMOHAN	D	NONE		

LDO FOR CLOCKS

REVISIONS			
REV	DESCRIPTION	DATE	APPROVED

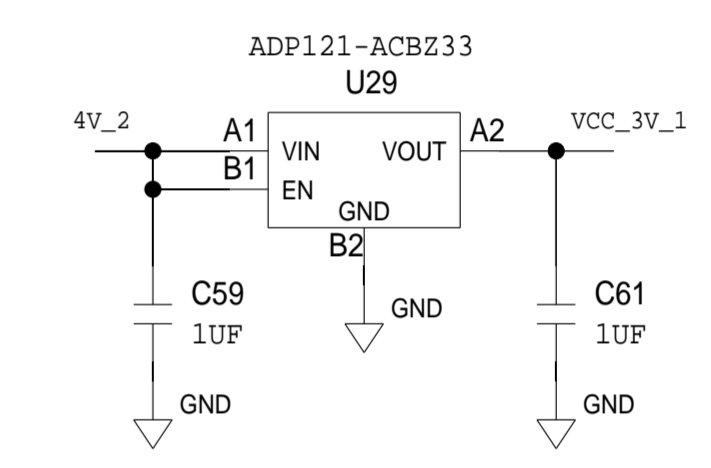
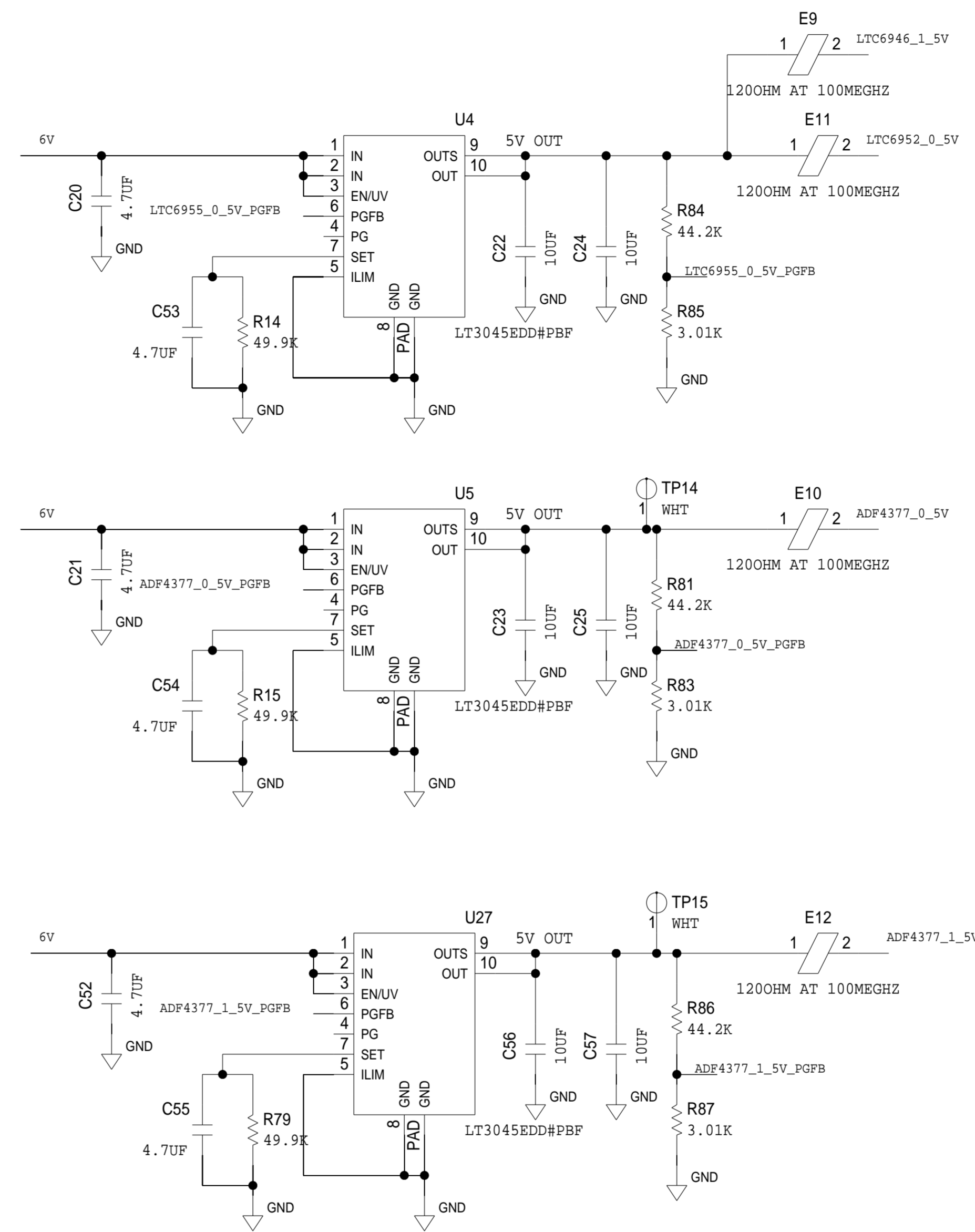
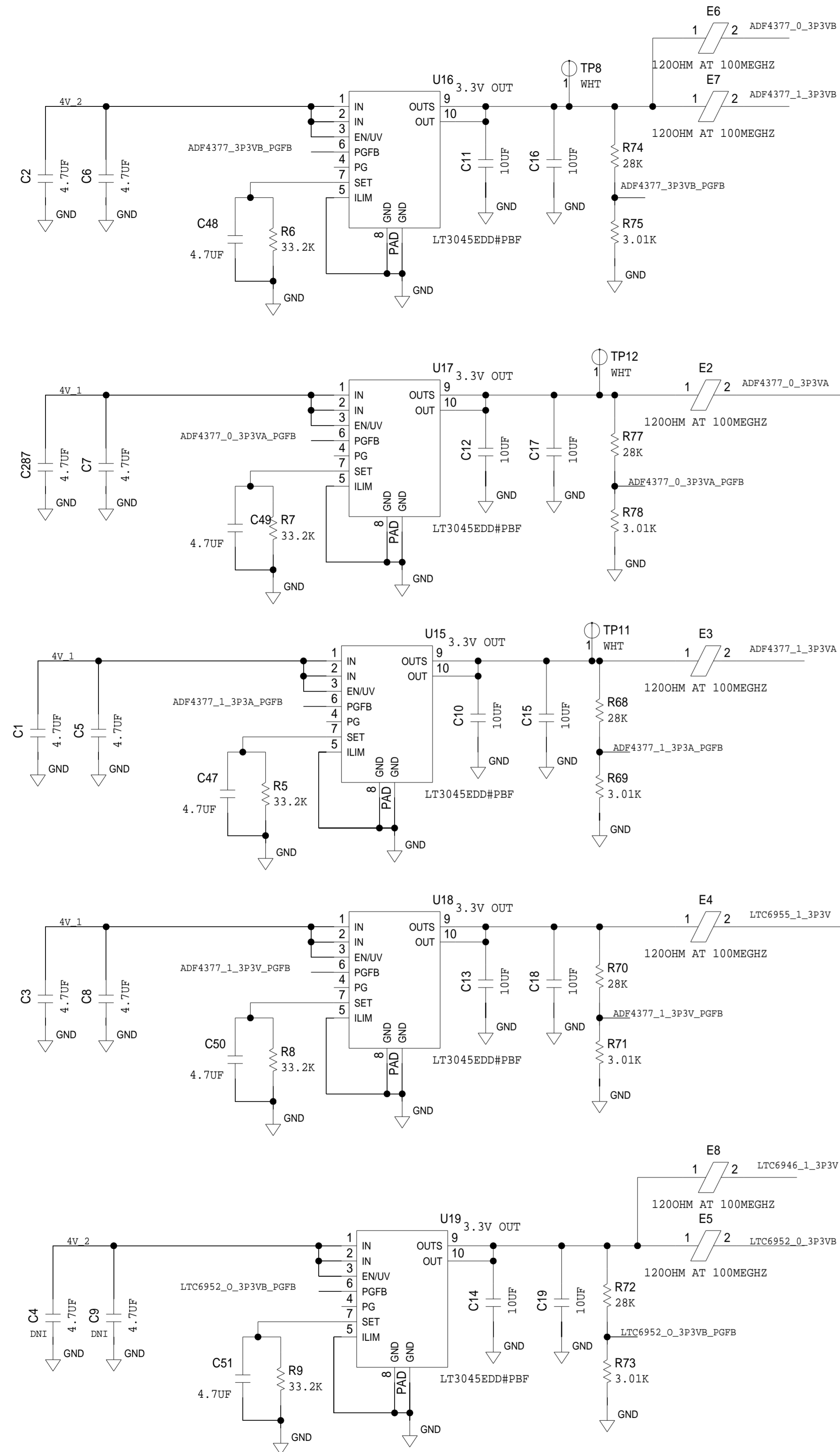

	SCHEMATIC			
	HW TYPE : Customer Evaluation Product(s): AD9213 : Dual Customer bd			
	DESIGN VIEW -	DRAWING NO. 02_049155	REV D	
	PTD ENGINEER UMESH JAYAMOHAN	SIZE D	SCALE NONE	SHEET 11 OF 16

AD9213 POWER

REVISIONS			
REV	DESCRIPTION	DATE	APPROVED

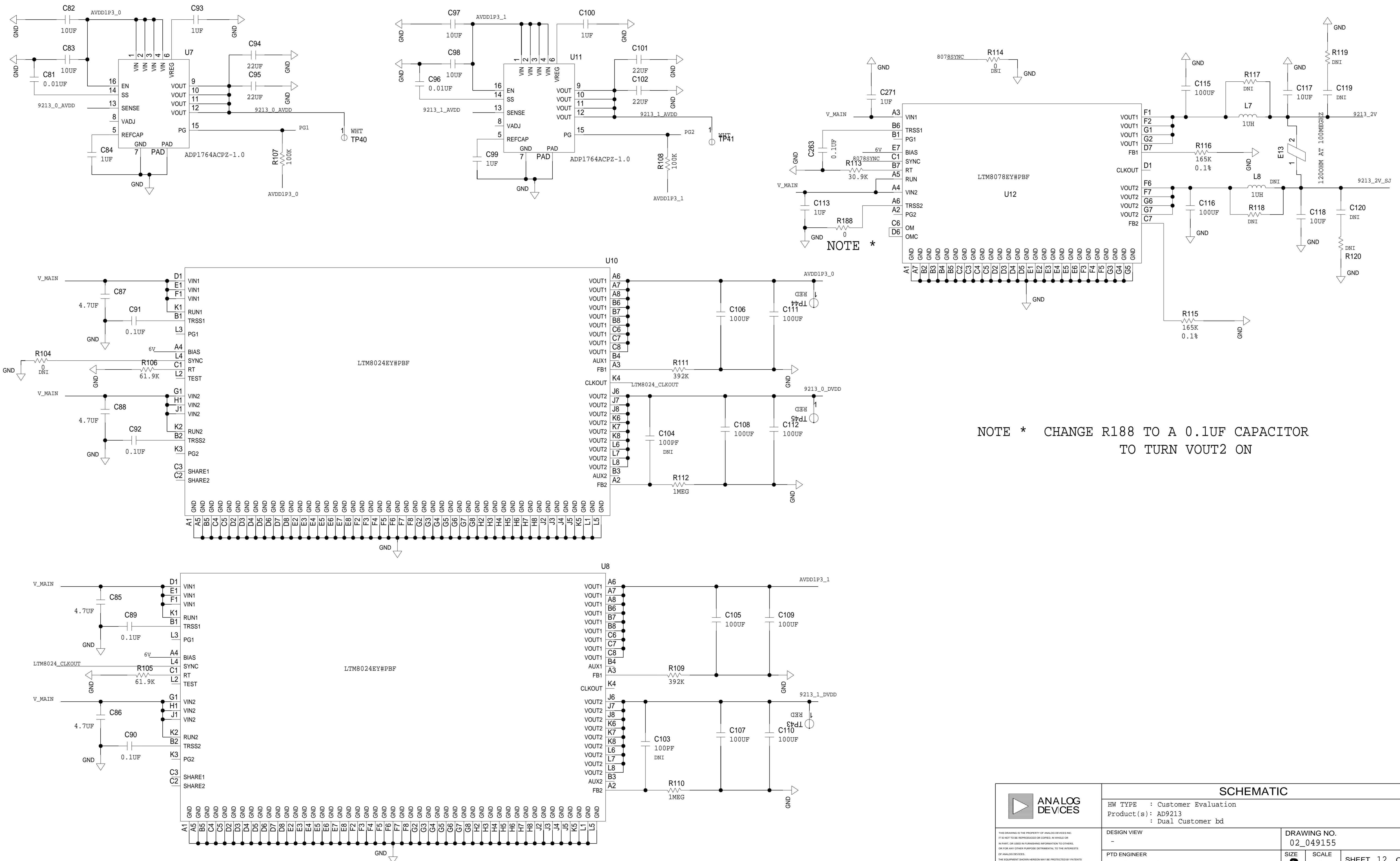

SCHEMATIC				
HW TYPE : Customer Evaluation Product(s) : AD9213 : Dual Customer bd		DESIGN VIEW -	DRAWING NO. 02_049155	REV D
PTD ENGINEER UMESH JAYAMOHAN		SIZE D	SCALE NONE	SHEET 12 OF 16

FMC BUFFERS - SPI, GPIO, RESET, PDWN, EEPROM, TRIG

REVISIONS			
REV	DESCRIPTION	DATE	APPROVED

3-WIRE SPI FOR AD9213_0 AND AD9213_1

4-WIRE SPI FOR LTC6952_0 AND LTC6952_1

EEPROM - BOARD ID
AD9213-10G-DUAL-EBZ

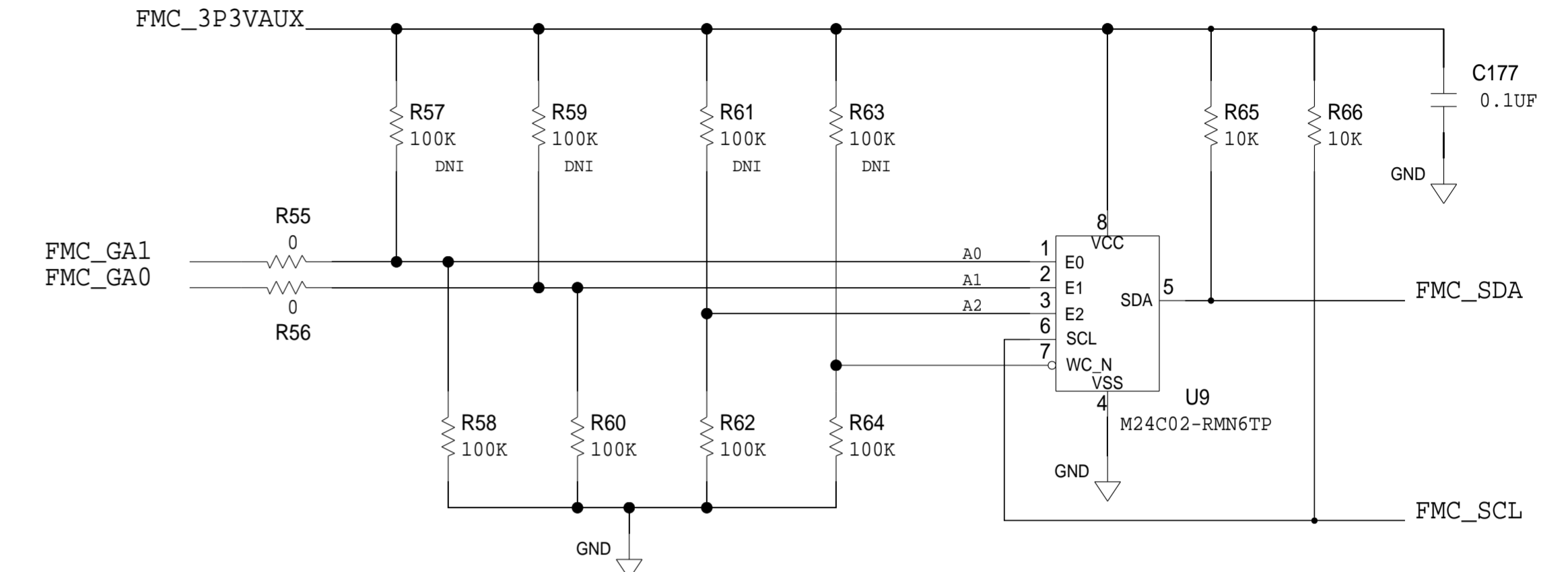
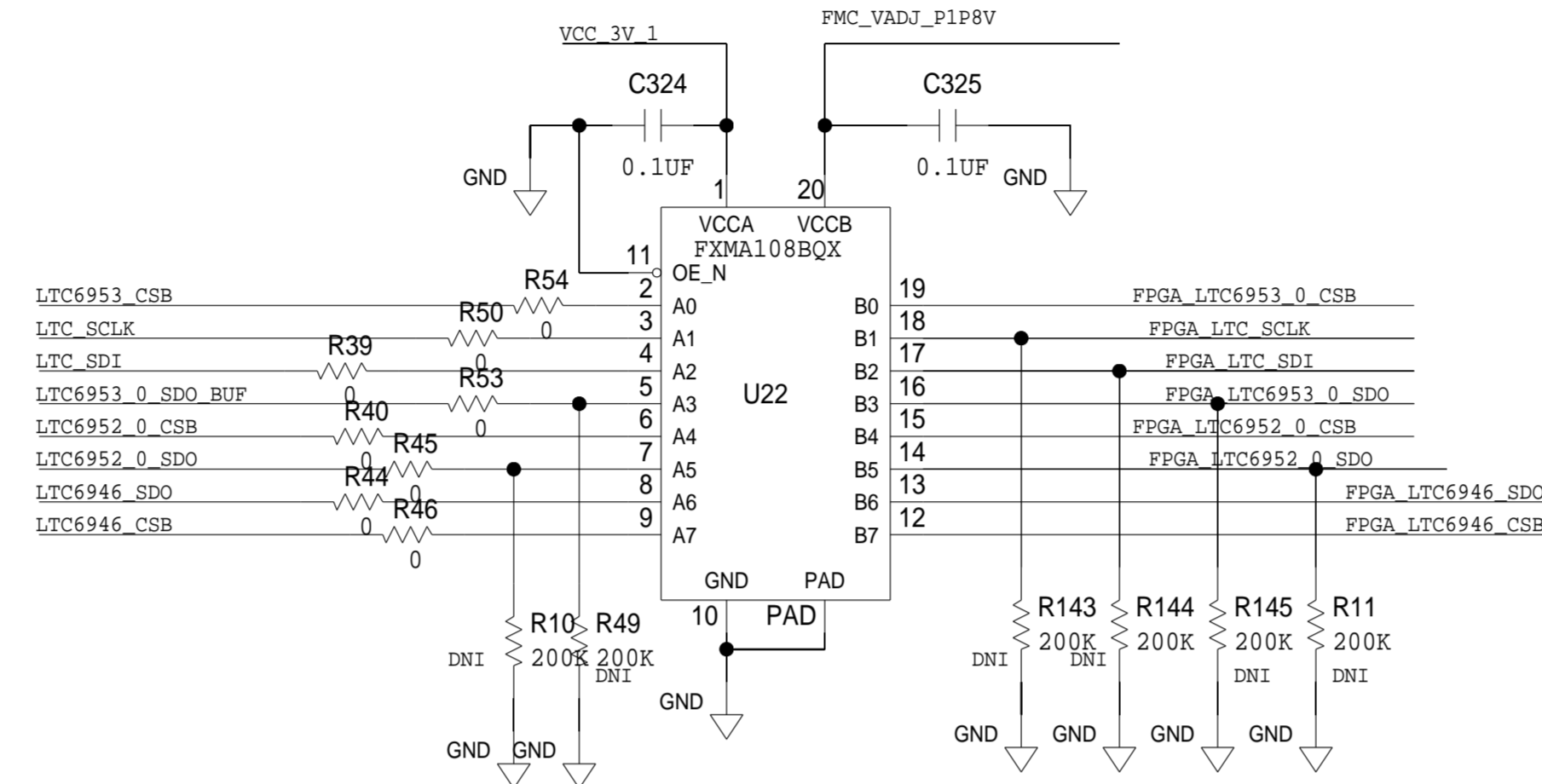
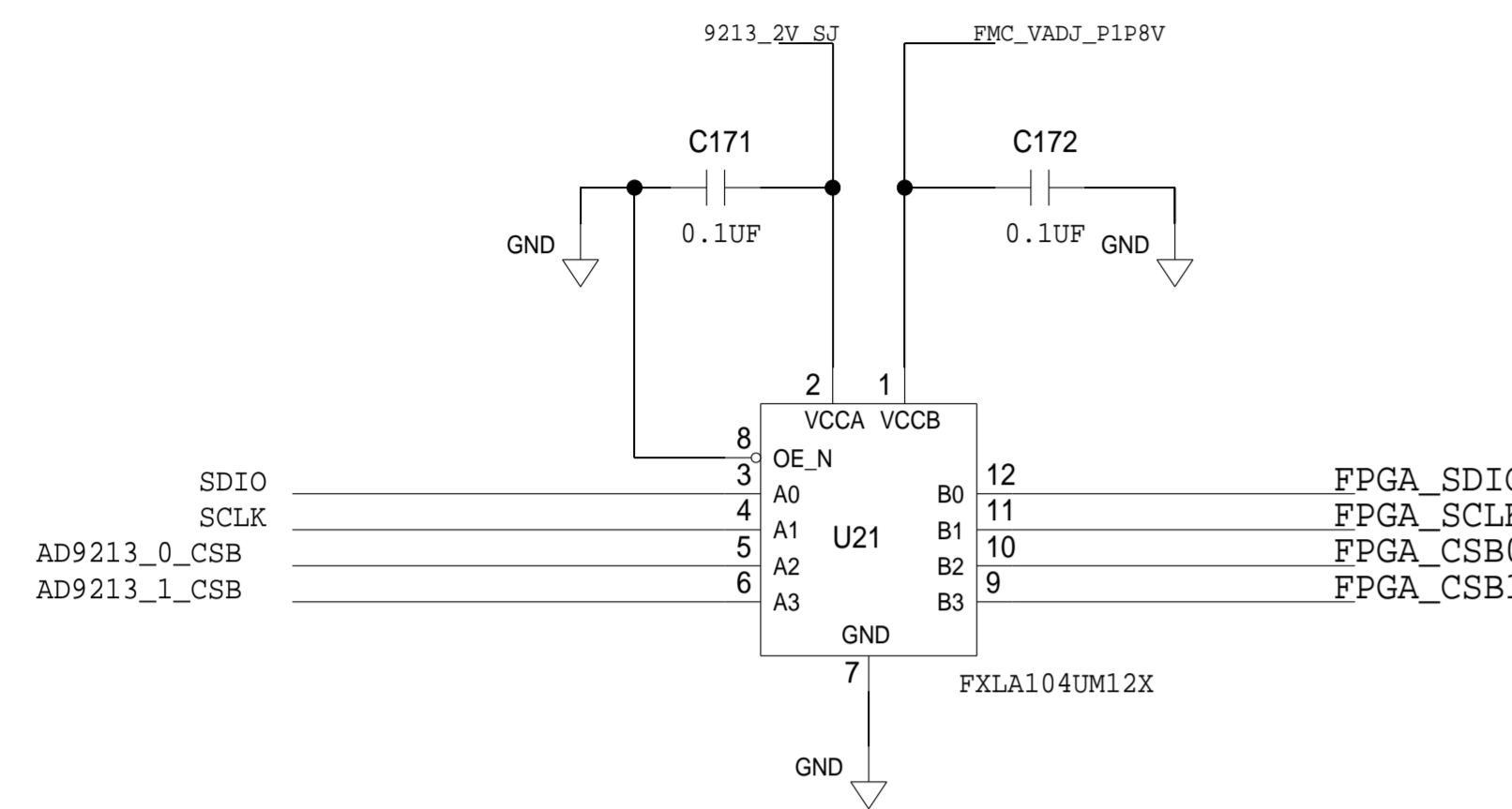

GPIOs AND RESET

3-WIRE SPI FOR ADF4377_0 AND ADF4377_1

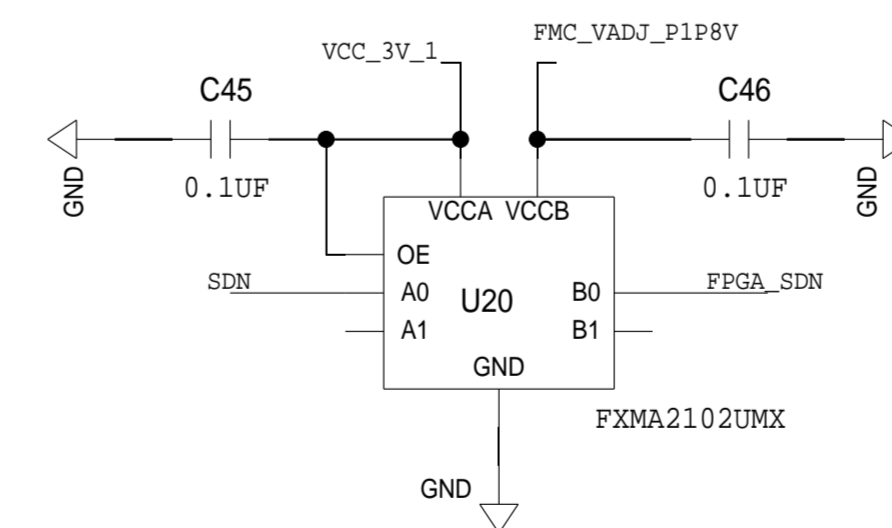
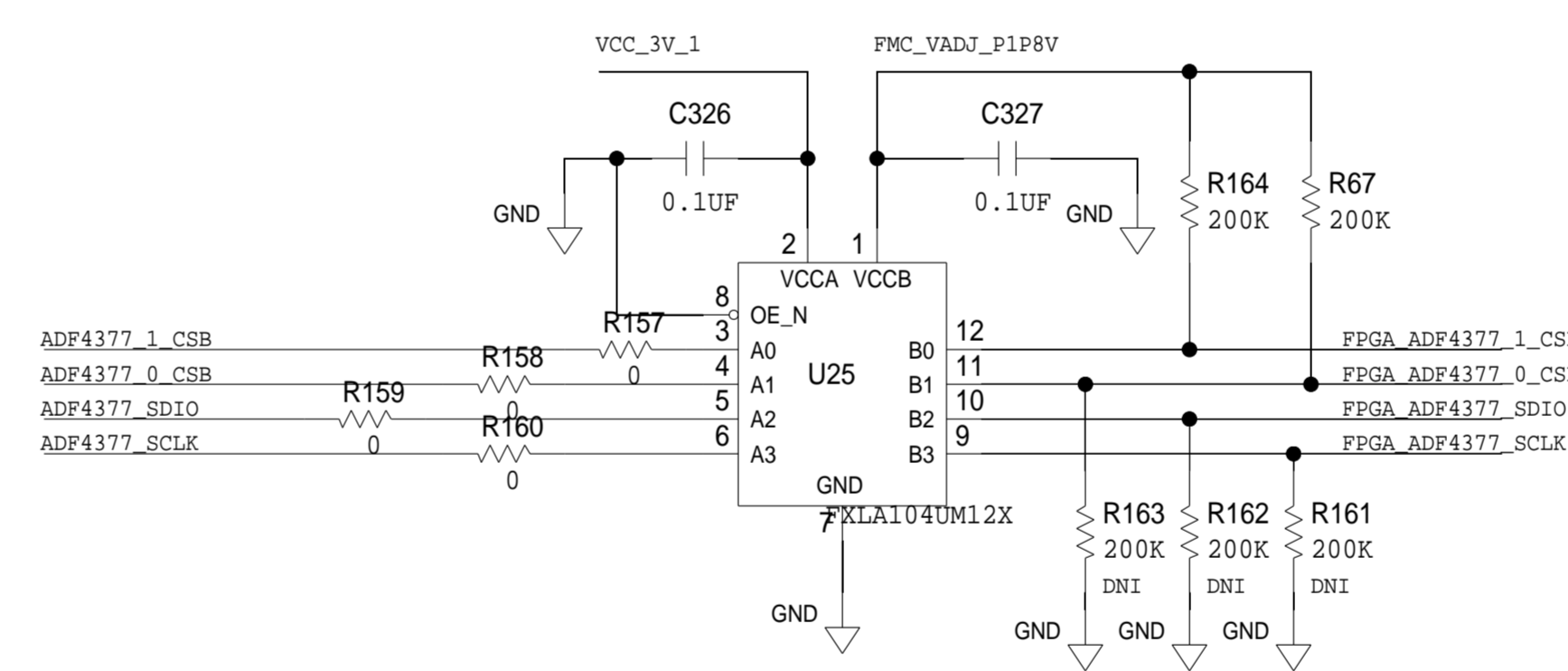
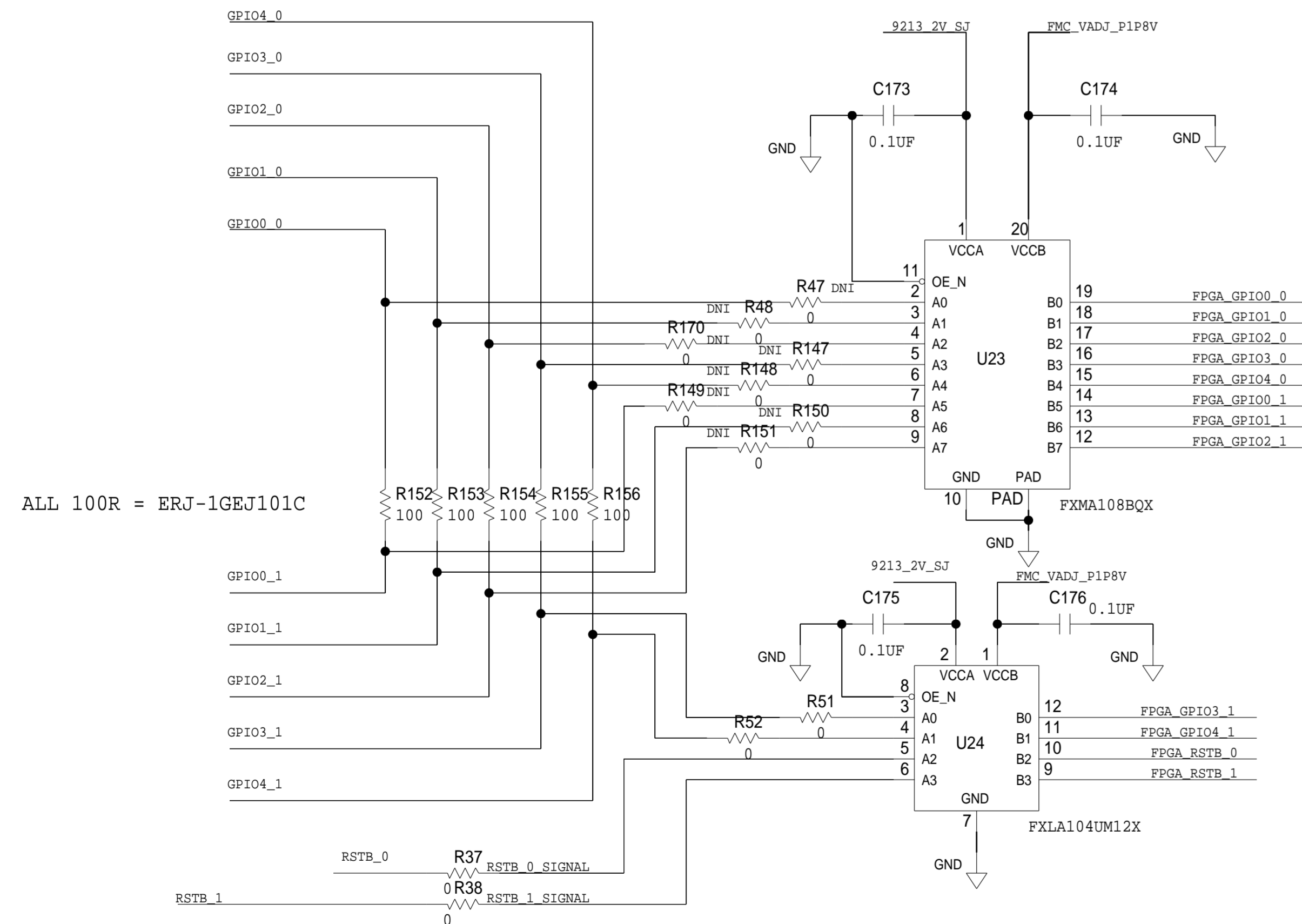

ANALOG DEVICES			
SCHEMATIC			
HW TYPE : Customer Evaluation Product(s): AD9213 : Dual Customer bd		DESIGN VIEW -	REV D
DRAWING NO. 02_049155		SIZE D	SCALE NONE
PTD ENGINEER UMESH JAYAMOHAN		SHEET 13 OF 16	

FMC+ HSPC CONNECTOR (P2)

REVISIONS			
REV	DESCRIPTION	DATE	APPROVED

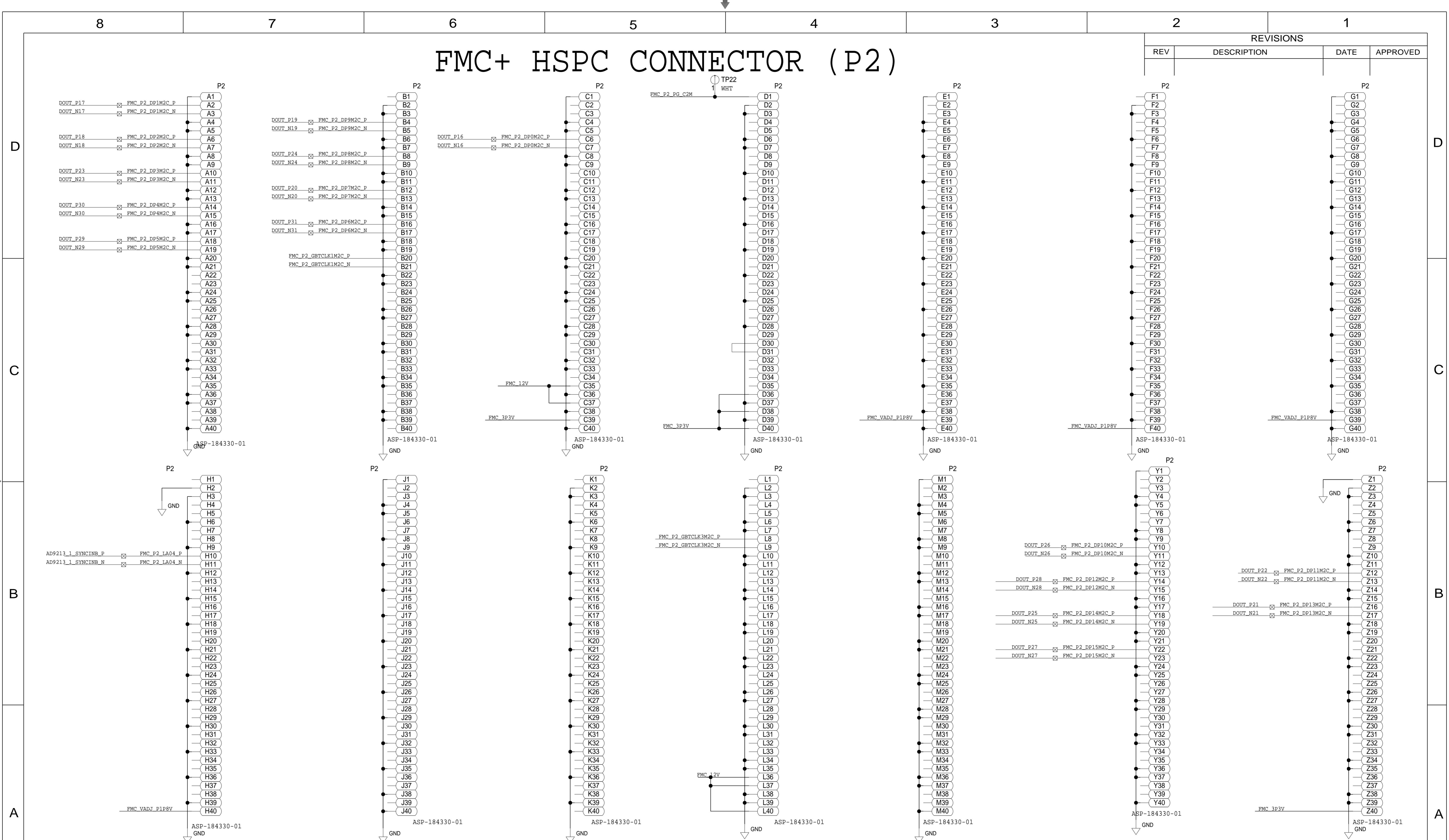

NOTE:SER_OUT PINS SHOULD BE FIT INTO ADJACENT QUADS 0-3,4-7,8-11,12-15,16-19
FPGA_SYNCINB SHOULD BE DIFF CMOS DRIVE

SCHEMATIC			
		HW TYPE : Customer Evaluation Product(s) : Ad9213 : Dual Customer bd	
DESIGN VIEW	-	DRAWING NO.	02_049155
PTD ENGINEER	UMESH JAYAMOHAN	SIZE	D
SCALE	NONE	SHEET	15 OF 16
REV	D		